

TOSHIBA
STORAGE DEVICE DIVISION

SD-M1401
DVD-ROM DRIVE
SCSI INTERFACE MANUAL

JULY 2000
VERSION 1.1

Specifications are subject to change without notice

DOCUMENT NUMBER
14459

©TOSHIBA CORPORATION 2000
ALL RIGHTS RESERVED

Contents

1	PREFACE	1
2	PHYSICAL CHARACTERISTICS	3
2.1	INTERFACE CONNECTOR	3
2.2	ELECTRICAL DESCRIPTION (EXCEPT ULTRA-SCSI)	4
2.3	ELECTRICAL DESCRIPTION (for ULTRA-SCSI)	4
2.4	SCSI ID	5
2.5	SCSI BUS SIGNALS	5
2.6	SIGNAL SOURCE IN EACH PHASE	6
3	LOGICAL CHARACTERISTICS	7
3.1	SCSI BUS PHASE	7
3.1.1	BUS FREE Phase	7
3.1.2	ARBITRATION Phase	8
3.1.3	SELECTION Phase	8
3.1.4	RESELECTION Phase	9
3.1.5	INFORMATION TRANSFER Phase	9
3.2	SCSI BUS CONDITION	12
3.2.1	ATTENTION Condition	12
3.2.2	RESET Condition	13
3.3	SCSI BUS PHASE SEQUENCE	13
4	MESSAGE	15
4.1	DETAILS OF MESSAGES	15
4.1.1	COMMAND COMPLETE Message	15
4.1.2	EXTENDED Message	15
4.1.3	MODIFY DATA POINTER Message	16
4.1.4	SYNCHRONOUS DATA TRANSFER REQUEST Message	17
4.1.5	EXTENDED IDENTIFY Message	17
4.1.6	WIDE DATA TRANSFER REQUEST Message	17
4.1.7	SAVE DATA POINTER Message	18
4.1.8	RESTORE POINTERS Message	18
4.1.9	DISCONNECT Message	18
4.1.10	INITIATOR DETECTED ERROR Message	18
4.1.11	ABORT Message	18
4.1.12	MESSAGE REJECT Message	18
4.1.13	NO OPERATION Message	19
4.1.14	MESSAGE PARITY ERROR Message	19
4.1.15	LINKED COMMAND COMPLETE Message	19
4.1.16	LINKED COMMAND COMPLETE with FLAG Message	19
4.1.17	BUS DEVICE RESET Message	19
4.1.18	IDENTIFY Message	19
4.2	COMMENTS ON MESSAGE CONTROL	20

5	COMMAND	23
5.1	OPERATION of DVD-ROM in SCSI	26
5.1.1	COMMAND OPERATION Type	26
5.1.2	DISCONNECT and RECONNECT Process	26
5.1.3	TYPE 4 Command Operation	27
5.1.4	Linked Command Operation	28
5.1.5	Selection of Invalid Logical Unit	29
5.1.6	UNIT ATTENTION CONDITION	29
5.2	UN-SUPPORTED COMMANDS	30
5.3	LIST OF COMMANDS	30
5.4	TEST UNIT READY command	32
5.5	REZERO command	33
5.6	REQUEST SENSE command	34
5.7	READ(6) command	36
5.8	SEEK(6) command	37
5.9	INQUIRY command	38
5.10	MODE SELECT(6) command	42
5.10.1	Mode Parameter Header	43
5.10.2	Block Descriptor(s)	43
5.10.3	Page Descriptor(s)	47
5.11	RESERVE command	49
5.12	RELEASE command	51
5.13	MODE SENSE(6) command	52
5.13.1	MODE PAGE setting	52
5.13.2	MODE SENSE data	53
5.13.3	Page 01 (Read/Write Error Recovery parameters)	54
5.13.4	Page 02 (Disconnect/Reconnect Control parameters)	58
5.13.5	Page 0D (Drive parameters)	59
5.13.6	Page 0E (CD Audio Control parameters)	59
5.13.7	Page 1A (Power Condition parameters)	61
5.13.8	Page 1D (C/DVD Time-out & Protect parameters)	63
5.13.9	Page 2Ah (Capability and Mechanical Status)	64
5.13.10	Return Page Parameters	67
5.14	START/STOP UNIT command	70
5.14.1	Load/Eject Operation	71
5.14.2	Spin Up/Down Operation	71
5.14.3	Power Change Operation	71
5.15	RECEIVE DIAGNOSTICS RESULTS command	72
5.16	SEND DIAGNOSTIC command	73
5.17	PREVENT ALLOW MEDIUM REMOVAL command	75
5.17.1	Persistent Prevent Operation	75
5.18	READ FORMAT CAPACITIES command	76
5.19	READ CAPACITY command	78
5.20	READ(10) command	80
5.21	SEEK(10) command	81
5.22	WRITE BUFFER command	82
5.23	READ SUB-CHANNEL command	83
5.23.1	CD-ROM Current Position Data (Format 01h)	85
5.23.2	Media Catalog Number Data (Format 02h)	86
5.23.3	Track ISRC Data (Format 03h)	87
5.24	READ TOC/PMA/ATIP command	88
5.24.1	Track Number Data (Format 0000b)	89
5.24.2	Session Number Data (Format 0001b)	90
5.24.3	Subcode-Q Data (Format 0010b)	91

5.24.4	CD Text Data (Format 0101b)	92
5.25	READ HEADER command	95
5.26	PLAY AUDIO(10) command	97
5.27	GET CONFIGURATION command	98
5.27.1	GET CONFIGURATION response data	99
5.27.2	Features	100
5.28	PLAY AUDIO MSF command	112
5.29	GET EVENT STATUS NOTIFICATION command	113
5.29.1	Operational Change/Notification	115
5.29.2	Power Management Status Class	116
5.29.3	External Request Status Class	117
5.29.4	Media Status Class	118
5.29.5	Multi-Host Class	119
5.29.6	Device Busy Class	119
5.30	PAUSE/RESUME command	120
5.31	STOP PLAY/SCAN command	121
5.32	READ DISC INFORMATION command	122
5.33	READ TRACK/RZONE INFORMATION command	126
5.34	MODE SELECT(10) command	130
5.35	MODE SENSE(10) command	131
5.36	SEND EVENT command	132
5.37	SEND KEY command	134
5.37.1	Accepts a Challenge Key (Format 000001b)	135
5.37.2	Accepts a KEY2 (Format 000011b)	135
5.37.3	Set Region (Format 000110b)	136
5.38	REPORT KEY command	138
5.38.1	Returns Authentication Grand ID (Format 000000b)	139
5.38.2	Returns Challenge Key (Format 000001b)	139
5.38.3	Returns KEY1 (Format 000010b)	140
5.38.4	Returns TITLE KEY (Format 000100b)	140
5.38.5	Returns Authentication Success Flag (Format 000101b)	141
5.38.6	Returns Drive Region Setting (Format 001000b)	141
5.39	PLAY AUDIO(12) command	143
5.40	SET READ AHEAD command	144
5.41	READ(12) command	145
5.42	GET PERFORMANCE command	146
5.43	READ DVD STRUCTURE command	148
5.43.1	Lead-in Structure (Format 00h)	149
5.43.2	Copyright Information (Format 01h)	151
5.43.3	Disc Key Structures (Format 02h)	151
5.43.4	BCA Structures (Format 03h)	152
5.43.5	Disc manufacturing Information (Format 04h)	153
5.43.6	Copyright Management Information (Format 05h)	153
5.43.7	Structure List (Format FFh)	154
5.44	SET STREAMING command	155
5.45	READ CD MSF command	157
5.46	SCAN command	159
5.47	SET CD SPEED command	161
5.48	MECHANISM STATUS command	162
5.49	READ CD command	163
5.49.1	Read CD command for DVD Media	166

6 SENSE DATA	167
6.1 Sense Key	169
6.2 Error Information Code	170

Chapter 1

PREFACE

This specification describes the SCSI interface implementation of following Toshiba DVD-ROM SD-M1401 drive. (As of June, 2000)

SCSI¹ is an interface which was established by ANSI² to specify the interface between host computers and intelligent peripheral devices.

The Toshiba DVD-ROM drive complies with ANSI standard X3.131-1986 SCSI(SCSI-1) and also complies with SCSI-2.

The Toshiba DVD-ROM drive also complies with SCSI-3 working draft about ultra-SCSI(Fast-20) option and CD-Text format of **READ TOC/PMA/ATIP** command.

The Toshiba DVD-ROM drive complies with the standard, **Small Form Factor** Committee specification of SFF-8090v3³.

The SD-M1401 has fully upper-compatible interface with common SCSI type CD-ROM drives. So, users can replace their CD-ROM drive with SD-M1401 without wasting their CD-ROM propriety.

The Toshiba DVD-ROM drive implemented **CopyProtection technology**. So, heading of protected data without preceding authentication protocol is prohibited.

A DVD disc can contain information on one side or on both sides. Single layer has up to 4.38GB⁴ and double sides/dual layer disc has up to 15.9GB capacity that is much improved from CD. Because of it's large capacity and high transfer data (1350KB/sec : 1x), high quality, long time MPEG-2 movie picture can be playback.

The SD-M1401 drive is designed to support not only DVD but also traditional CD-ROM data and CD-ROM XA format.

Namely ECC⁵ for XA format is handled inside the drive and error correction is carried out if necessary. The CD-ROM XA standard is an extended standard adopting traditional CD-ROM Mode-2 format and consistent with ISO 9660 standard which defines the volume and file structure of CD-ROM.

The traditional CD-ROM has adopted Mode-1 format, mostly handling character data, on the other hand, CD-ROM XA standard enables a long-time(UP to 16 hours) ADPCM⁶ audio recording and simultaneous playback of text, graphics, images and audio.

It is expected that CD-ROM XA will realize multi-media application through DVD-ROM drive on the personal computer.

In addition to above, the Toshiba DVD-ROM drive supports CD-DA⁷ data transfer over SCSI function that CD-DA data along with subcode-Q address data or subcode R thru W is available through the SCSI interface.

¹SCSI: Small Computer System Interface

²ANSI: American National Standard Institute

³SFF-8090v3 Revision 1.0: Mt. Fuji Commands for Multimedia Devices

⁴1GB = 1,024KB = 1,048,576Bytes

⁵ECC: Error Correction Code

⁶ADPCM: Adaptive Differential Pulse Code Modulation

⁷CD-DA: CD-Digital Audio

This function enables to play CD audio with a DAC⁸ located at host system.

In addition to SCSI asynchronous data transfer mode, the Toshiba DVD-ROM drive supports synchronous mode that is used in data phase where large amount of data is transferred.

The maximum burst transfer rate in synchronous mode is 20 Mbytes/s.

Namely Toshiba DVD-ROM drive complies ULTRA-SCSI.

This fast transfer rate contributes to minimize SCSI bus occupation time of transferring data and enables to improve the throughput of SCSI bus.

Maximum sustained transfer rate is improved to be over 13,500 Kbytes/s(DVD:10x), 6,000 Kbytes/s(CD-ROM:40x), whereas CD-Audio playback rate is 1378 Kbytes/s(CD-DA:8.0x)⁹.

That is, new Toshiba DVD-ROM drive is able to satisfy the requirement to increase the transfer rate to host PCs as fast as possible.

In combination with the burst transfer rate of 20 Mbytes/s, the data transfer efficiency is remarkably improved.

The Toshiba DVD-ROM drive supports Kodak Photo-CD implementation which is based upon the extended CD-ROM specification of Orange Book.

That is, it is able to read a multisession disc and READ TOC command are prepared anew to transfer the information as to the offset of the last session.

The Toshiba DVD-ROM drive also supports CD-Text format which is based upon the extended CD specification. That is, READ TOC/PMA/ATIP command is able to read the Subcode R thru W data in Lead-in area.

The MSF¹⁰ addressing format is valid only for CD media inserted on the Toshiba DVD-ROM drive.

⁸DAC: Digital Audio Converter

⁹ $\frac{2048\text{bytes} \times 75\text{frames/sec}}{1024} \times 40 = 6000\text{Kb/s}$, $\frac{2352\text{bytes} \times 75\text{frames/sec}}{1024} \times 8 = 1378\text{Kb/s}$

¹⁰MSF: Min/Sec/Frame addressing

Chapter 2

PHYSICAL CHARACTERISTICS

2.1 INTERFACE CONNECTOR

The Toshiba DVD-ROM drive uses a 50-conductor connector consisting of two rows that complies with SCSI.

It uses single-ended driver/receiver alternatives and it allow a maximum cumulative cable length of 6 meter¹.

Table 2.1 shows the single-ended contact assignments.

The *underline sign* to the signal shows “Active low”.

CONTACT NUMBER	SIGNAL NAME	CONTACT NUMBER	SIGNAL NAME
1	GROUND	26	<u>DB(0)</u>
2	GROUND	27	<u>DB(1)</u>
3	GROUND	28	<u>DB(2)</u>
4	GROUND	29	<u>DB(3)</u>
5	GROUND	30	<u>DB(4)</u>
6	GROUND	31	<u>DB(5)</u>
7	GROUND	32	<u>DB(6)</u>
8	GROUND	33	<u>DB(7)</u>
9	GROUND	34	<u>DB(P)</u>
10	GROUND	35	GROUND
11	GROUND	36	GROUND
12	GROUND	37	GROUND
13	OPEN	38	TERMPWR
14	GROUND	39	GROUND
15	GROUND	40	GROUND
16	GROUND	41	<u>ATN</u>
17	GROUND	42	GROUND
18	GROUND	43	<u>BSY</u>
19	GROUND	44	<u>ACK</u>
20	GROUND	45	<u>RST</u>
21	GROUND	46	<u>MSG</u>
22	GROUND	47	<u>SEL</u>
23	GROUND	48	<u>C/D</u>
24	GROUND	49	<u>REQ</u>
25	GROUND	50	<u>I/O</u>

Table 2.1: Single-Ended Contact Assignments

¹for Ultra SCSI(Fast-20), it is allowed to 3 meter (up to 4 devices) or 1.5 meter (up to 8 device)

2.2 ELECTRICAL DESCRIPTION (EXCEPT ULTRA-SCSI)

There are three kinds of signals, driven by the initiator, driven by the target, driven the initiator and target at once.

Each signal driven by SCSI device must have following output characteristics.

$$\begin{aligned} \text{TRUE} : \quad V_{OL} &= 0.0 \sim 0.5 \text{ Volts DC} \\ &I_{OL} = 48 \quad \text{mA Min} \\ \text{FALSE} : \quad V_{OH} &= 2.5 \sim 5.25 \text{ Volts DC} \end{aligned}$$

When OL : Low-level output
 OH : High-level output

SCSI device shall meet following electrical characteristics on each signal.

$$\begin{aligned} \text{TRUE} : \quad V_{IL} &= 0.0 \sim 0.8 \text{ Volts DC} \\ &I_{IL} = -0.4 \quad \text{mA Max}(0.5V \text{ DC}) \\ \text{FALSE} : \quad V_{IH} &= 2.0 \sim 5.25 \text{ Volts DC} \\ \text{HYSTERISIS} : &0.2 \quad \text{Volts DC Min} \end{aligned}$$

When IL : Low-level input
 IH : High-level input

All signals except for GROUND, OPEN and TERMPWR shall terminated at both ends of the SCSI cable.

The passive termination of each signal should consist of 220 Ω & (to +5V) and 330 Ω & (to GROUND) which is defined in SCSI.

2.3 ELECTRICAL DESCRIPTION (for ULTRA-SCSI)

For Fast-20 option (Ultra-SCSI), some electrical characteristics are different from traditional definition which is mentioned in section 2.2

Each signal driven by SCSI device must have following output characteristics.

$$\begin{aligned} \text{TRUE} : \quad V_{OL} &= 0.0 \sim 0.5 \text{ Volts DC} \\ &I_{OL} = 48 \quad \text{mA Min} \\ \text{FALSE} : \quad V_{OH} &= 2.5 \sim 3.7 \text{ Volts DC} \end{aligned}$$

When OL : Low-level output
 OH : High-level output

SCSI device shall meet following electrical characteristics on each signal (including both receivers and disabled drivers).

$$\begin{aligned} \text{TRUE} : \quad V_{IL} &= 1.0 \text{ Volts DC}(\text{maximum}) \\ &I_{IL} = \pm 20 \mu\text{A at } V_I = 0.5V \text{ DC} \\ \text{FALSE} : \quad V_{IH} &= 1.9 \text{ Volts DC}(\text{maximum}) \\ &I_{IH} = \pm 20 \mu\text{A at } V_I = 2.7V \text{ DC} \\ \text{Input HYSTERISIS} : &0.3 \text{ Volts DC Min} \end{aligned}$$

When IL : Low-level input
 IH : High-level input

All signals except for GROUND, OPEN and TERMPWR shall terminated at both ends of the SCSI cable.

The passive termination of each signal should consist of 220 Ω & (to +5V) and 330 Ω & (to GROUND) which is defined in SCSI.

2.4 SCSI ID

Communication on the SCSI bus is always performed between two SCSI devices.

One device acts as an initiator which originates an operation with sending commands and the other device acts as a target which receives the command and executes it.

Each SCSI device has a SCSI ID bit assigned as shown in below.

SCSI ID = 7 has the highest priority and 0 has the lowest.

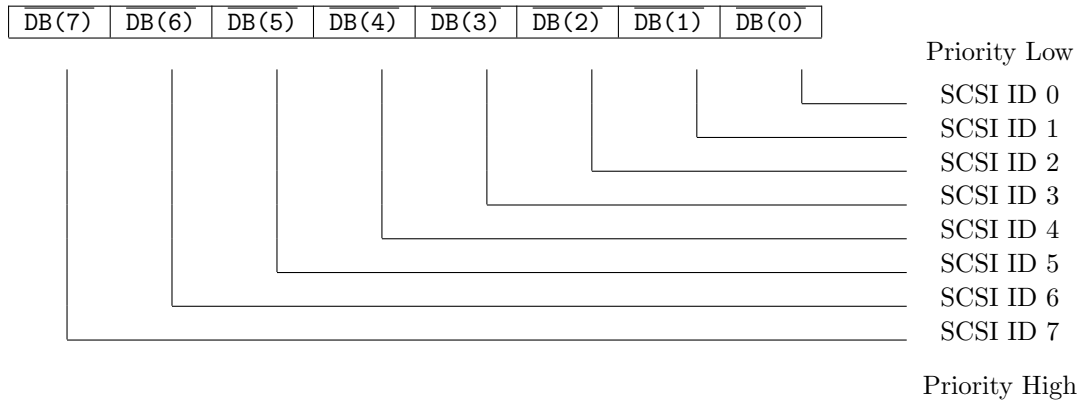

Table 2.2: SCSI ID Bits

2.5 SCSI BUS SIGNALS

There are a total of 18 signals, 9 of which are used for control signal lines and the remaining 9 are used for data signal lines.

As each signal is active low on the SCSI bus, hereafter, “1” stands for low(true) and “0” stands for high(false).

SCSI signals are described as follows.

1. $\overline{DB(7)} - \overline{DB(0)}, \overline{DB(P)}$ < Data Bus >
 Bi-directional eight data-bit ($\overline{DB(7)}$ to $\overline{DB(0)}$) plus an odd parity bit ($\overline{DB(P)}$).
 $\overline{DB(7)}$ is the most significant bit (MSB) and $\overline{DB(0)}$ is the (LSB).
 The meaning of data bus differs from each phase and defined as follows.
 - (a) ARBITRATION phase
 To gain the control of SCSI bus, the SCSI device asserts a single bit corresponding to $\overline{DB(0)}$.
 $\overline{DB(7)}$ has the highest priority during this phase and the priority decreases downward to $\overline{DB(0)}$. During ARBITRATION phase, $\overline{DB(P)}$ is not valid.
 - (b) SELECTION and RESELECTION phase
 Used to output the SCSI ID of initiator and/or target.
 - (c) INFORMATION TRANSFER phase
 Used to transfer command, status and message between initiator and target.
 $\overline{DB(P)}$ is an odd parity bit used to confirm the priority of transfer.
2. \overline{BSY} < Busy >
 Used by either initiator and target to indicate that the SCSI bus is being busy.
3. \overline{SEL} < Select >
 Used by the initiator to select a target and used by the target to reselect an initiator.
4. $\overline{C/D}$ < Control/Data >
 Used by the target to indicate whether the information is a control data (command, status and message) or data.
 “1” shows control and “0” shows data.

5. $\overline{I/O}$ < Input/Output >
Used by the target to indicate whether the direction of data transfer with respect to the initiator. "1" shows direction from the target to initiator and "0" shows direction from the initiator to target.
Also this signal issued to distinguish between SELECTION and RESELECTION phase.
6. \overline{MSG} < Message >
Used by the target to indicate the MESSAGE phase.
"1" shows the MESSAGE phase.
7. \overline{REQ} < Request >
Driven by the target used for the request of $\overline{REQ}/\overline{ACK}$ handshake.
8. \overline{ACK} < Acknowledge >
Driven by the initiator used for the acknowledge of $\overline{REQ}/\overline{ACK}$ handshake.
9. \overline{ATN} < Attention >
Used by the initiator to indicate the attention condition.
10. \overline{RST} < Reset >
An OR-tied signal that indicates the RESET condition.

2.6 SIGNAL SOURCE IN EACH PHASE

Table 2.3 shows the SCSI devices as signal source for each phase on the SCSI bus.

BUS PHASE	SCSI SIGNALS				
	\overline{BSY}	\overline{SEL}	$\overline{C/D,I/O},$ $\overline{MSG,REQ}$	\overline{ACK} \overline{ATN}	$\overline{DB(x)}$
Bus Free	NONE	NONE	NONE	NONE	NONE
Arbitration	ALL	WIN	NONE	NONE	SCSI ID
Selection	INITIATOR & TARGET	INITIATOR	NONE	INITIATOR	INITIATOR
Reselection	INITIATOR & TARGET	TARGET	TARGET	INITIATOR	TARGET
Command	TARGET	NONE	TARGET	INITIATOR	INITIATOR
Data IN	TARGET	NONE	TARGET	INITIATOR	TARGET
Data OUT	TARGET	NONE	TARGET	INITIATOR	INITIATOR
Status	TARGET	NONE	TARGET	INITIATOR	TARGET
Message OUT	TARGET	NONE	TARGET	INITIATOR	INITIATOR
Message IN	TARGET	NONE	TARGET	INITIATOR	TARGET

NONE : Not used by any SCSI device
 ALL : Driven by all SCSI devices arbitrating
 WIN : Driven by the SCSI device which wins the ARBITRATION phase
 SCSI ID : DATA BUS bits corresponding to the SCSI ID in ARBITRATION
 INITIATOR & TARGET : Used by initiator, target or both device
 INITIATOR : Used by initiator device
 TARGET : Used by target device

Table 2.3: Bus Phase and Signal Sources

Chapter 3

LOGICAL CHARACTERISTICS

3.1 SCSI BUS PHASE

There are eight phase defined below, however note that no more than one phase shall occur at any time.

In the following descriptions, signals are “0” (false) unless otherwise notes.

Phase 5. to 8. are termed the INFORMATION TRANSFER phase.

1. BUS FREE phase
2. ARBITRATION phase
3. SELECTION phase
4. RESELECTION phase
5. COMMAND phase
6. DATA phase
7. STATUS phase
8. MESSAGE phase

3.1.1 BUS FREE Phase

This phase is used to indicate that the SCSI bus is not being used by any SCSI devices. The SCSI device shall detect BUS FREE phase when the $\overline{\text{RST}}$, $\overline{\text{BSY}}$ and $\overline{\text{SEL}}$ signals are both **zero** for at least 400 ns ¹. When BUS FREE phase is detected, the SCSI device must release all asserting signals (set to **zero**) within 800 ns ². If the SCSI device requires more than 400 ns to detect the BUS FREE phase, the SCSI device must release all signals within 800 ns ² minus BUS FREE detection time plus 400 ns ². Namely the maximum time to clear the SCSI bus is 1.2 μs ³ from detecting BUS FREE phase. The DVD-ROM drive normally shifts to BUS FREE phase after one of following occurrences.

1. After RESET condition
2. After ABORT message is received by the DVD-ROM drive
3. After DISCONNECT message is transferred from the DVD-ROM drive to the initiator
4. After COMMAND COMPLETE message is transferred from the DVD-ROM drive to the initiator

¹400 ns : BUS SETTLE DELAY

²800 ns : BUS CLEAR DELAY

³1.2 μs : BUS SETTLE DELAY + BUS CLEAR DELAY

However note that at any time, the DVD-ROM drive may release $\overline{\text{BSY}}$ signal and start BUS FREE phase to indicate a fatal error condition (unexpected disconnect). In this case, it is recommended that the initiator should issue REQUEST SENSE command to obtain sense data of which the DVD-ROM drive may hold.

3.1.2 ARBITRATION Phase

This phase determines which SCSI device gains control of the SCSI bus to become the initiator or target. Although this optional, it shall be implemented if multiple initiators are connected and/or the system is as follows.

1. Wait for the BUS FREE phase to occur.
2. After detecting BUS FREE phase, the SCSI device asserts both $\overline{\text{BSY}}$ signal and its own SCSI ID during 800 ns^4 to $1.8\ \mu\text{s}^5$. Note that only one DATA BUS bit (Corresponding to its SCSI ID) shall be asserted and other seven DATA BUS bit should be released (not driven). The DB(P) (parity) is not valid during this phase and may be released or driven to true value.
3. After at least $2.2\ \mu\text{s}^6$ from asserting $\overline{\text{BSY}}$ signal, examine the DATA BUS.
 - (a) Lost ARBITRATION(1)
If a higher priority SCSI ID is detected, the SCSI device immediately release all signals and returns to step 1.
 - (b) Win ARBITRATION
If no higher priority SCSI ID is detected, the SCSI device asserts $\overline{\text{SEL}}$ signal to indicate that it gains the control of SCSI bus.
 - (c) Lost ARBITRATION(2)
If the $\overline{\text{SEL}}$ signal becomes **one**, the SCSI device executing ARBITRATION phase must release all signals within 800 ns^2 and should return to step 1.
4. The SCSI device which wins the ARBITRATION waits at least $1.2\ \mu\text{s}^3$ after asserting $\overline{\text{SEL}}$ signal before proceeding to next phase and then completes the ARBITRATION phase.

3.1.3 SELECTION Phase

This phase is used by the initiator to select a target. During this phase, $\overline{\text{I/O}}$ signal should be set to **zero** to distinguish this phase from RESELECTION phase.

When ARBITRATION phase is not used, the SELECTION procedure should be as follows.

1. The initiator waits for the BUS FREE phase to occur and then waits more than 800 ns^4 .
2. The initiator sets the DATA BUS to a values that corresponds to target's SCSI ID. To identify its own SCSI ID, the initiator's SCSI ID might be output together with the target's SCSI ID. Note that the initiator shall drive all DATA BUS bits unlike the ARBITRATION phase. Also the initiator must assure the DB(P) signal if the parity check is permitted.

When ARBITRATION phase is used, the SELECTION procedure should be as follows.

1. After completion of ARBITRATION phase (the initiator must wait at least $1.2\ \mu\text{s}$ after asserting $\overline{\text{BSY}}$ and $\overline{\text{SEL}}$ signals), the initiator set the DATA BUS to an OR value of the target and own SCSI ID. It is not an error to set only target's SCSI ID if there is a single initiator and if DISCONNECT process is not used.
2. The initiator waits at least 90 ns^7 and releases the $\overline{\text{BSY}}$ signal.

⁴800 ns: BUS FREE DELAY

⁵1.8 μs : BUS SET DELAY

⁶2.2 μs : ARBITRATION DELAY

⁷90 ns: Two DESKEW DELAYs

3. The initiator examines the response from the target after 400 ns^1 from releasing the $\overline{\text{BSY}}$ signal.

The target responds to the SELECTION phase as described below regardless the implementation of ARBITRATION phase.

1. The target checks whether the $\overline{\text{SEL}}$ signal and its SCSI ID bit on DATA BUS is set to **one** and the $\overline{\text{BSY}}$ and $\overline{\text{I/O}}$ signal are set to **zero** for at least 400 ns^1 . The selected target then examines the DATA BUS to determine the SCSI ID of the selecting initiator.
2. The target asserts the $\overline{\text{BSY}}$ signal to respond to the initiator within a maximum of $200\text{ }\mu\text{s}^8$. If more than two SCSI ID bits are detected on the DATA BUS or a parity error is detected, the target does not respond to the SELECTION phase.
3. After at least 90 ns^7 after detecting the $\overline{\text{BSY}}$ signal set to **one**, the initiator sets the $\overline{\text{SEL}}$ signal to **zero** and completes the SELECTION phase.

3.1.4 RESELECTION Phase

This phase is used by the target to reconnect (select) the initiator to resume the suspended operation. During this phase, $\overline{\text{I/O}}$ signal should be set to **one** to distinguish this phase from SELECTION phase. The target first executes ARBITRATION phase to gain the control of the SCSI bus and then performs following procedure.

1. Completing the ARBITRATION phase (the target waits at least $1.2\text{ }\mu\text{s}$ after asserting $\overline{\text{BSY}}$ and $\overline{\text{SEL}}$ signals), the target sets the DATA BUS to an OR value of the initiator and its own SCSI ID. At the same time, the target asserts the $\overline{\text{I/O}}$ signal to indicate RESELECTION phase.
2. The target waits at least 90 ns^7 and releases the $\overline{\text{BSY}}$ signal

The initiator should respond to the RESELECTION phase as described below.

1. The initiator checks whether the $\overline{\text{SEL}}$ and $\overline{\text{I/O}}$ signal and its SCSI ID bit on DATA BUS is set to **one** and the $\overline{\text{BSY}}$ signal is set to **zero** for at least 400 ns^1 . The reselected initiator then examines the DATA BUS to determine the SCSI ID of the reselecting target.
2. The initiator asserts the $\overline{\text{BSY}}$ signal to respond to the target within a maximum of $200\text{ }\mu\text{s}^8$. If more than two SCSI ID bits are detected on the DATA BUS or a parity error is detected, the initiator should not respond to the RESELECTION phase.
3. After detecting the $\overline{\text{BSY}}$ signal set to **one**, the target also asserts the $\overline{\text{BSY}}$ signal and waits at least 90 ns^7 and then sets the $\overline{\text{SEL}}$ signal to **zero**.
4. After the initiator detects the $\overline{\text{BSY}}$ signal set to **zero**, it releases the $\overline{\text{BSY}}$ signal. Hereafter, the $\overline{\text{BSY}}$ signal is asserted by the target until SCSI bus link is completed.

If no response is detected for 250 ms^9 from the initiator, the DVD-ROM drive shifts to BUS FREE phase and then retries the RESELECTION phase.

3.1.5 INFORMATION TRANSFER Phase

This phase allows to transfer command, data, status and message via DATA BUS. Types and directions of the information is distinguished by the $\overline{\text{C/D}}$, $\overline{\text{I/O}}$ and $\overline{\text{MSG}}$ signals which are driven by the target as shown in Table 3.1.

INFORMATION TRANSFER phase uses $\overline{\text{REQ}}/\overline{\text{ACK}}$ handshakes to control the information transfer. During INFORMATION TRANSFER phase, the $\overline{\text{BSY}}$ signal is set to **one** and the $\overline{\text{SEL}}$ signal is set to **zero**. Three control signals, $\overline{\text{C/D}}$, $\overline{\text{I/O}}$ and $\overline{\text{MSG}}$, are valid for 400 ns^1 before the assertion of first $\overline{\text{REQ}}$ signal and they are maintained until the negation of the last $\overline{\text{ACK}}$ signal. Following restrictions are applied to the SCSI bus signals between two INFORMATION TRANSFER phases.

⁸200 μs : SELECTION ABORT TIME

⁹250 ms : Recommended SELECTION TIME-OUT DELAY

SIGNAL			PHASE NAME	DIRECTION OF TRANSFER	
MSG	C/D	I/O			
0	0	0	Data OUT	Initiator →	Target
0	0	1	Data IN	Initiator ←	Target
0	1	0	Command	Initiator →	Target
0	1	1	Status	Initiator ←	Target
1	0	0	Reserved		
1	0	1	Reserved		
1	1	0	Message OUT	Initiator →	Target
1	1	1	Message IN	Initiator ←	Target

Table 3.1: Information Transfer Phase

1. The $\overline{\text{BSY}}$, $\overline{\text{SEL}}$, $\overline{\text{REQ}}$ and $\overline{\text{ACK}}$ signals shall not change.
2. The $\overline{\text{C/D}}$, $\overline{\text{I/O}}$, $\overline{\text{MSG}}$ and DATA BUS signals may change.
3. The $\overline{\text{ATN}}$ and $\overline{\text{RST}}$ signal may change within the range specified in each section.

The DVD-ROM drive supports asynchronous and synchronous information transfer mode as follows.

Asynchronous Information Transfer Mode

The target controls the direction of data transfer by the $\overline{\text{I/O}}$ signal as follows.

If the $\overline{\text{I/O}}$ signal is “1” (target to initiator), the procedure shall be as follows.

1. The target drives the DATA BUS to desired value.
2. The target waits at least 55 ns^{10} and then asserts the $\overline{\text{REQ}}$ signal.
3. The initiator reads the DATA BUS after the $\overline{\text{REQ}}$ signal goes to **one** and then asserts the $\overline{\text{ACK}}$ signal after a minimum of 10 ns after detection of the $\overline{\text{REQ}}$ signal set to **one** to respond to the target.
4. The target sets the $\overline{\text{REQ}}$ signal to **zero** when the $\overline{\text{ACK}}$ signal goes to **one**. The target may change the DATA BUS signal at this point and so the initiator should read the DATA BUS before asserting the $\overline{\text{ACK}}$ signal.
5. The initiator negates the $\overline{\text{ACK}}$ signal after minimum of 10 ns after detection of the $\overline{\text{REQ}}$ signal negation.
After the $\overline{\text{ACK}}$ signal is set to **zero**, the target may return to step 1 above and may continue data transfer.

If the $\overline{\text{I/O}}$ signal is “0” (initiator to target), the procedure shall be as follows.

1. The target asserts the $\overline{\text{REQ}}$ signal to request the initiator to transfer data.
2. The initiator drives the DATA BUS to desired value.
3. The initiator waits at least 55 ns^{10} and then asserts the $\overline{\text{ACK}}$ signal to respond to the target.
4. The target reads the DATA BUS after the $\overline{\text{ACK}}$ signal goes to **one** and then negates the $\overline{\text{REQ}}$ signal to respond to the initiator.

¹⁰55 ns: DESKEW DELAY + CABLE SKEW DELAY

- The initiator sets the $\overline{\text{ACK}}$ signal to **zero** after a minimum 10 *ns* from detecting the negation of the $\overline{\text{REQ}}$ signal.
After the $\overline{\text{ACK}}$ signal is set to **zero**, the target may return to step 1 above and may continue data transfer.

The DVD-ROM drive implements following $\overline{\text{REQ}}/\overline{\text{ACK}}$ handshake time-out procedure. During any INFORMATION TRANSFER phase, if the DVD-ROM drive waits about 30 seconds after asserting of $\overline{\text{REQ}}$ signal and there has been no $\overline{\text{ACK}}$ signal response (assertion) from the initiator, it aborts the command and shifts to BUS FREE phase (unexpected disconnect). In this case, the DVD-ROM drive prepares a sense data of INTERNAL TARGET FAILURE.

Synchronous Information Transfer Mode

Synchronous data transfer is optional of SCSI and is only used in data phases if synchronous data transfer agreement has been established between the initiator and the target prior to data phase. The SDTR¹¹ message exchange (negotiation) establishes the permissible TRANSFER PERIOD and $\overline{\text{REQ}}/\overline{\text{ACK}}$ OFFSET to be used. Regarding SDTR message exchange, refer to Section 4.1.4 EXTENDED Message. The $\overline{\text{REQ}}/\overline{\text{ACK}}$ OFFSET establishes a pacing mechanism and specifies the maximum number of $\overline{\text{REQ}}$ pulses that can be sent by the target in advance of the number of $\overline{\text{ACK}}$ pulses. If the number of $\overline{\text{REQ}}$ pulses exceeds the number of $\overline{\text{ACK}}$ pulses by established $\overline{\text{REQ}}/\overline{\text{ACK}}$ OFFSET, the target does not assert the $\overline{\text{REQ}}$ signal (keep the $\overline{\text{REQ}}$ signal inactive) until the leading edge of next $\overline{\text{ACK}}$ pulse is received. Fig 3.2 shows the example when the $\overline{\text{REQ}}/\overline{\text{ACK}}$ OFFSET is set to 3.

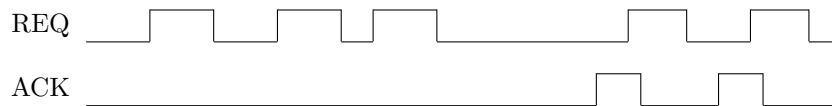

Table 3.2: Synchronous Information Phase ($\overline{\text{REQ}}/\overline{\text{ACK}}$ Offset)

The TRANSFER PERIOD specifies the minimum time allowed between leading edge of successive $\overline{\text{REQ}}$ pulses and of successive $\overline{\text{ACK}}$ pulses to meet the device requirements for successful reception of data. The data transfer mode that the negotiated TRANSFER PERIOD is less than 200 *ns* is called “Fast synchronous data transfer” mode and specific parameters such as FAST ASSERTION PERIOD are used, however the DVD-ROM drive does not support this optional mode.

The target asserts the $\overline{\text{REQ}}$ signal for a minimum of 90 *ns*¹² and then waits at least the greater of a TRANSFER PERIOD before asserting the next $\overline{\text{REQ}}$ signal. The initiator shall send one $\overline{\text{ACK}}$ pulse for each $\overline{\text{REQ}}$ pulse received. The initiator may assert the $\overline{\text{ACK}}$ signal as soon as the leading edge of the corresponding $\overline{\text{REQ}}$ pulse is received and then shall assert the $\overline{\text{ACK}}$ signal for a minimum of 90 *ns*¹².

As well as the target, the initiator shall wait at least the greater of a TRANSFER PERIOD before asserting next $\overline{\text{ACK}}$ signal. The target controls the direction of data transfer by the $\overline{\text{I/O}}$ signal as follows.

If the $\overline{\text{I/O}}$ signal is “1” (target to initiator), the procedure shall be as follows.

- The target drives the DATA BUS to desired value.
- The target waits at least 55 *ns*¹⁰ and then asserts the $\overline{\text{REQ}}$ signal.
- The target holds the DATA BUS valid for a minimum of 100 *ns*¹³ after the assertion of the $\overline{\text{REQ}}$ signal.

¹¹SDTR: Synchronous Data Transfer Request

¹²90 *ns*: ASSERTION PERIOD

¹³100 *ns*: DESKEW DELAY + CABLE SKEW DELAY + HOLD TIME

4. The target asserts the $\overline{\text{REQ}}$ signal for a minimum of 90 ns^{12} and then may negate the $\overline{\text{REQ}}$ signal and change the DATA BUS signal.
The target may return to step 1 above and may continue data transfer.
5. The initiator reads the DATA BUS within 45 ns^{14} of the transition of the $\overline{\text{REQ}}$ signal to true and then responds with an $\overline{\text{ACK}}$ pulse.

If the $\overline{\text{I/O}}$ signal is “0” (initiator to target), the procedure shall be as follows.

1. The target asserts the $\overline{\text{REQ}}$ signal to request the initiator to transfer data.
2. After receiving the leading edge of the $\overline{\text{REQ}}$ signal, the initiator drives the DATA BUS to desired value.
3. The initiator waits at least 55 ns^{10} and then asserts the $\overline{\text{ACK}}$ signal to respond to the target.
4. The initiator holds the DATA BUS valid for a minimum of 100 ns^{13} after the assertion of the $\overline{\text{ACK}}$ signal.
5. The initiator asserts the $\overline{\text{ACK}}$ signal for a minimum of 90 ns^{12} .
6. The target reads the DATA BUS within 45 ns^{14} of the transition of the $\overline{\text{ACK}}$ signal to true. The target may return to step 1 above and may continue data transfer.

At Ultra-SCSI or FAST-SCSI, some parameters are changed as follows,

TIMING DESCRIPTION	FAST-20	FAST	SLOW
Cable Skew Delay	3 ns	4 ns	4 ns
Receive Assertion/Negation Period	11 ns	22 ns	70 ns
Receive Hold Time	11.5 ns	25 ns	25 ns
Receive Setup Time	6.5 ns	15 ns	15 ns
Transfer Period during Synchronous Data Transfer Phase	50 ns	100 ns	200 ns
Transmit Assertion/Negation Period	15 ns	30 ns	80 ns
Transmit Hold Time	16.5 ns	33 ns	53 ns
Transmit Setup Time	11.5 ns	23 ns	23 ns

Table 3.3: Fast-20/Fast SCSI timing description

For more details, refer to SCSI-3 Fast-20 working draft specification.

3.2 SCSI BUS CONDITION

There are two asynchronous conditions, ATTENTION condition and RESET condition, and they can force to change the phase sequence.

3.2.1 ATTENTION Condition

ATTENTION condition indicates that the initiator has a message to inform the target. The initiator can create this condition by asserting the $\overline{\text{ATN}}$ signal at any time except ARBITRATION and BUS FREE phase. Upon detection of the $\overline{\text{ATN}}$ signal assertion, the target enters MESSAGE OUT phase to receive the message. To transfer more than one message byte, the initiator shall keep the $\overline{\text{ATN}}$ signal asserted until the last byte. Normally the initiator should negate the $\overline{\text{ATN}}$ signal while the $\overline{\text{REQ}}$ signal

¹⁴10 ns: HOLD TIME

is **one** and the $\overline{\text{ACK}}$ signal is **zero** during the last $\overline{\text{REQ}}/\overline{\text{ACK}}$ handshake of the MESSAGE OUT phase. Basically the target continues MESSAGE OUT phase until the $\overline{\text{ATN}}$ signal goes to **zero**, except message rejection. If the DVD-ROM drive receives all message successfully, it shifts to any INFORMATION TRANSFER phase other than MESSAGE OUT phase or shifts to BUS FREE phase immediately. Regarding message parity error handling, refer to 4.2 COMMENTS ON MESSAGE CONTROL. The DVD-ROM drive responds to the MESSAGE OUT phase as follows.

1. If the $\overline{\text{ATN}}$ signal goes true during SELECTION phase, the DVD-ROM drive enters MESSAGE OUT phase after SELECTION phase.
2. If the $\overline{\text{ATN}}$ signal goes true during RESELECTION phase, the DVD-ROM drive enters MESSAGE OUT phase after it has sent its IDENTIFY message to the initiator.
3. If the $\overline{\text{ATN}}$ signal goes true during COMMAND or STATUS phase, the DVD-ROM drive enters MESSAGE OUT phase after transferring all COMMAND/STATUS data.
4. If the $\overline{\text{ATN}}$ signal goes true during DATA phase except DATA IN phase due to READ command execution (burst mode DATA IN phase), the DVD-ROM drive executes DATA IN phase until last byte and then enters MESSAGE OUT phase.
5. If the $\overline{\text{ATN}}$ signal goes true during DATA IN phase due to READ command execution (burst mode DATA IN phase), the DVD-ROM drive enters MESSAGE OUT phase on block boundary.
6. If $\overline{\text{ATN}}$ signal goes true during MESSAGE IN phase, the DVD-ROM drive enters MESSAGE OUT phase before it sends another message.

3.2.2 RESET Condition

The RESET condition has the highest priority over any phases and conditions and it resets all SCSI devices and clears the SCSI bus. Any SCSI device can create this condition by asserting the $\overline{\text{RST}}$ signal for a minimum 25 μs ¹⁵ and all SCSI device shall shift to BUS FREE phase by releasing all SCSI bus signals except the $\overline{\text{RST}}$ signal. Upon the detection of RESET condition, the DVD-ROM drive implements “Hard Reset” alternative as the SftRe bit of INQUIRY data indicates and it implements;

1. Abort the current command execution and clear the command queue if exist.
2. Release all reservations.
3. Set all operation mode to their default value. The synchronous data transfer agreement which might be established previously becomes invalid and goes to asynchronous transfer mode.
4. Set unit attention condition.

Namely the DVD-ROM drive implements exactly same operation as power-on reset.

3.3 SCSI BUS PHASE SEQUENCE

Basically the phase transition is controlled by the target except the ATTENTION and RESET condition. The RESET condition has the highest priority and it aborts any phase and the BUS FREE phase follows always. The initiator can create ATTENTION condition at any time by asserting the $\overline{\text{ATN}}$ signal. In the case of NON-ARBITRATION system (SCSI-2 does not recommend), the normal progression is from BUS FREE phase to SELECTION phase, from SELECTION phase to one or more INFORMATION TRANSFER phases. In the case of ARBITRATION system, phase shifts from BUS FREE phase to ARBITRATION phase, then shifts to either SELECTION or RESELECTION phase and one or more INFORMATION TRANSFER phases follow. In both cases, there are no restriction on the phase transition during INFORMATION TRANSFER phase, so the same phase may

¹⁵25 μs : RESET HOLD TIME

be implemented repeatedly. Normally, the final INFORMATION TRANSFER phase is MESSAGE IN phase where DISCONNECT or COMMAND COMPLETE message is transferred and the BUS FREE phase follows. However note that the DVD-ROM drive may shift to BUS FREE phase from any phase upon a detection of fatal error (unexpected disconnect error).

Chapter 4

MESSAGE

The message system (bi-directional information) is used to control the SCSI bus phase sequence between the initiator and the target. Message is transferred during either MESSAGE IN phase or MESSAGE OUT phase and it may be one, two, or multiple bytes in length. The first byte of the message is called message code and it indicates the function of the message. Table 4.1 shows the message format and Table 4.2 shows the message code/name that the Toshiba DVD-ROM drive supports.

MESSAGE CODE	MESSAGE FORMAT
00h	One-byte message (COMMAND COMPLETE)
01h	Extended message
02 - 1Fh	One-byte message
20 - 2Fh	Two-bytes message
30 - 7Fh	Reserved
80 - FFh	One-byte message (IDENTIFY)

Table 4.1: Message Format

4.1 DETAILS OF MESSAGES

This section describes the messages that the DVD-ROM drive supports in detail. Meaning of symbols used in this section is as follows.

- I** → **T** : Message sent from initiator to DVD-ROM drive
- I** ← **T** : Message sent from DVD-ROM drive to initiator
- I** ↔ **T** : Message sent bi-directionally between initiator and target

4.1.1 COMMAND COMPLETE Message (I←T)

Sent from the DVD-ROM drive to the initiator to indicate that the execution of a single command or the last command of a series of linked commands has completed and valid status has been transferred to the initiator. The status byte transferred prior to this message shows whether the command has been completed successfully or not. After sending this message, the DVD-ROM drive goes to BUS FREE phase by releasing the $\overline{\text{BSY}}$ signal and terminates the command execution.

4.1.2 EXTENDED Message (I↔T)

Table 4.3 shows the Extended message format and Table 4.4 shows the Extended message code/name.

MESSAGE CODE	MESSAGE NAME	Target ↔ Initiator	Initiator ↔ Target
00h	Command Complete	○	
01h	Extended Message	○	○
02h	Save Data Pointer	○	
03h	Restore Pointers	○	
04h	Disconnect	○	
05h	Initiator Detected Error		○
06h	Abort		○
07h	Message Reject	○	○
08h	No Operation		○
09h	Message Parity Error		○
0Ah	Linked Command Complete	○	
0Bh	Linked Command Complete (With Flag)	○	
0Ch	Bus Device Reset		○
0D - 11h	Not supported one-byte message		
0D - 1Fh	Reserved one-byte message		
20 - 23h	Not supported two-bytes message		
24 - 2Fh	Reserved two-bytes message		
30 - 7Fh	Reserved		
80 - FFh	Identify	○	○

Table 4.2: Message Code/Name List

BYTE	VALUE	DESCRIPTION
00	01h	Message code
01	N	Extended message length
02	y	Extended message code
03 - $N + 1$	x	Extended message arguments

Table 4.3: EXTENDED Message Format

EXTENDED(y) MESSAGE CODE	MESSAGE NAME	Target → Initiator	Initiator → Target
00h	Modify Data Pointer	(○)	
01h	Synchronous Data Transfer Request	○	○
02h	Reserved (Extended Identify)	(○)	(○)
03h	Wide Data Transfer Request	(○)	○
04 - 7Fh	Reserved		
80 - FFh	Vendor Specific (Not used)		

Table 4.4: EXTENDED Message Code/Name List

4.1.3 MODIFY DATA POINTER Message (I←T)

The DVD-ROM drive does not send this message.

4.1.4 SYNCHRONOUS DATA TRANSFER REQUEST Message (I↔T)

Table 4.5 shows SDTR¹ message format.

BYTE	VALUE	DESCRIPTION
00	01h	Message Code (Extended message)
01	03h	Extended message length
02	01h	SYNCHRONOUS DATA TRANSFER REQUEST code
03	<i>m</i>	TRANSFER PERIOD ($m \times 4ns$)
04	<i>x</i>	$\overline{REQ}/\overline{ACK}$ OFFSET

Table 4.5: SDTR Message Format

SDTR message is used by either the initiator and the DVD-ROM drive to establish a new data transfer agreement (either synchronous and asynchronous). An SCSI device (Usually initiator) may initiate an SYNCHRONOUS DATA TRANSFER REQUEST (SDTR) message exchange whenever it is appropriate to negotiate, however note that the DVD-ROM drive does not initiate SDTR message exchange at any time. This established agreement remains in effect until the DVD-ROM drive has been reset by power-on reset, RESET condition or BUS DEVICE RESET message. Once one of above three conditions occurs, the DVD-ROM drive goes to default data transfer mode of asynchronous mode.

The SDTR message exchange establishes the permissible TRANSFER PERIOD and the $\overline{REQ}/\overline{ACK}$ OFFSET. The TRANSFER PERIOD is the minimum time allowed between leading edge of successive \overline{REQ} pulses and of successive \overline{ACK} pulses. The $\overline{REQ}/\overline{ACK}$ OFFSET is the maximum number of \overline{REQ} pulses allowed to be outstanding before the leading edge of corresponding \overline{ACK} pulses is received at the DVD-ROM drive. A $\overline{REQ}/\overline{ACK}$ OFFSET value of zero indicates asynchronous transfer mode and a value of FFh indicates unlimited $\overline{REQ}/\overline{ACK}$ OFFSET.

If the initiator recognizes negotiation is required, it creates ATTENTION condition and then sends SDTR message (sets its value to permit to receive data successfully) during MESSAGE OUT phase. The DVD-ROM drive responds with SDTR message that is sent during MESSAGE IN phase as follows.

1. If the DVD-ROM drive can transfer data successfully with these values, it returns the same values in its SDTR message.
2. If the DVD-ROM drive requires a larger TRANSFER PERIOD, it substitutes values in its SDTR message as required.

If the initiator asserts the \overline{ATN} signal following the above MESSAGE IN phase and it sends MESSAGE REJECT message, the agreement is considered to be negated and the DVD-ROM drive goes to asynchronous transfer mode.

4.1.5 EXTENDED IDENTIFY Message (I↔T)

(SCSI-1 only) This message is only defined in SCSI-1 and deleted in SCSI-2. The DVD-ROM drive returns MESSAGE REJECT message to this message.

4.1.6 WIDE DATA TRANSFER REQUEST Message (I↔T)

Since the DVD-ROM drive only supports eight-bit data transfer mode, it returns MESSAGE REJECT message after receiving all bytes of this message.

¹SDTR: SYNCHRONOUS DATA TRANSFER REQUEST

4.1.7 SAVE DATA POINTER Message (I←T)

Used by the DVD-ROM drive to direct the initiator to store the active data pointer into the saved data pointer prepared for DVD-ROM drive. Normally the DVD-ROM drive sends this message prior to sending DISCONNECT message during READ command execution. However note that it does not send this message for first disconnection (after COMMAND phase) since the active data pointer is equal to the saved data pointer at this moment. The DVD-ROM drive may request the initiator to restore the active data pointer from the saved data pointer by sending RESTORE POINTERS message. Also the active data pointer should be restored from the saved pointer for IDENTIFY message sent from the DVD-ROM drive during reconnection (implied RESTORE POINTERS).

4.1.8 RESTORE POINTERS Message (I←T)

Used by the DVD-ROM drive to direct the initiator to restore the active pointers from most recently saved pointers prepared for DVD-ROM drive (command pointer, status pointer and data pointer). Command and status pointer shall be restored to the beginning value of current command being executed. Data pointer shall be restored to the most recently saved value which was stored by last SAVE DATA POINTER message or to the beginning value of current command being executed if SAVE DATA POINTER message has not been issued. This message is only sent if the initiator has sent IDENTIFY message after SELECTION phase. For further details, refer to Section 4.2 COMMENTS ON MESSAGE CONTROL.

4.1.9 DISCONNECT Message (I←T)

Used by the DVD-ROM drive to notify the initiator to disconnect current SCSI bus connection, but later the DVD-ROM drive will reconnect to complete the suspended command execution. After sending this message successfully, the DVD-ROM drive releases the $\overline{\text{BSY}}$ signal and goes to BUS FREE phase. However note that this message does not direct the initiator to save the active pointers. Regarding disconnect process, refer to Section 5.1.2 DISCONNECT and RECONNECT Process.

4.1.10 INITIATOR DETECTED ERROR Message (I→T)

Used by the initiator to inform that an error occurred during INFORMATION TRANSFER phase and to request retry operation. Upon receiving this message and if a retry operation is possible, the DVD-ROM drive normally sends RESTORE POINTERS message at first and then re-execute the SCSI bus phase preceding this MESSAGE OUT phase. For further details, refer to Section 4.2 COMMENTS ON MESSAGE CONTROL. The initiator should restore pointers upon the receipt of RESTORE POINTER message. The DVD-ROM drive may reject this request by sending MESSAGE REJECT message if a retry operation is not possible.

4.1.11 ABORT Message (I→T)

Used by the initiator to request the DVD-ROM drive to abort active command operation plus queued command (if exist). The DVD-ROM drive shifts to BUS FREE phase following receipt of this message and status or message are not returned. The DVD-ROM drive only clears the operation related to the initiator which sends this message, that is, the operations related to other initiators are not cleared.

4.1.12 MESSAGE REJECT Message (I↔T)

Sent from either the initiator or the DVD-ROM drive to indicate that the last received message was invalid or impossible to implement. If the initiator intends to send this message, it shall assert the $\overline{\text{ATN}}$ signal before the $\overline{\text{ACK}}$ signal of the last message byte is set to **zero**. Then the DVD-ROM drive detects this ATTENTION condition and proceeds to MESSAGE OUT phase. When the DVD-ROM drive intends to send this message in response to the message from the initiator, it shifts to MESSAGE IN phase after negation of the $\overline{\text{ACK}}$ signal during MESSAGE OUT phase. Note that during

multiple-message transfer such as EXTENDED message, the MESSAGE OUT phase may be aborted immediately (start MESSAGE IN phase) when the DVD-ROM drive decides to reject the message.

4.1.13 NO OPERATION Message (I→T)

Used by the initiator to notify that the initiator currently has no valid message to send.

4.1.14 MESSAGE PARITY ERROR Message (I→T)

Used by the initiator to indicate that the last received message had a parity error. If the initiator intends to send this message, it must assert the \overline{ATN} signal prior to the negation of the \overline{ACK} signal for which a parity error was detected. The DVD-ROM drive enters MESSAGE OUT phase in response to the ATTENTION condition, so the initiator can send MESSAGE PARITY ERROR message. Then the DVD-ROM drive re-executes MESSAGE IN phase to transfer entire same message to the initiator. Note that the initiator should not send this message following an INFORMATION TRANSFER phase other than MESSAGE IN phase. In this case, the DVD-ROM drive goes to BUS FREE phase (unexpected disconnect).

4.1.15 LINKED COMMAND COMPLETE Message (I←T)

Used by the DVD-ROM drive to indicate that the execution of a linked command (Link bit = 1) with Flag bit set to **zero** has completed and valid status byte has been sent to the initiator. The initiator shall confirm the status bytes and then updates the pointers to the initial value for the next linked command.

4.1.16 LINKED COMMAND COMPLETE with FLAG Message (I→T)

Used by the DVD-ROM drive to indicate that the execution of a linked command (Link bit = 1) with Flag bit set to **one** has completed and valid status byte has been sent to the initiator. The initiator shall confirm the status bytes and then updates the pointers to the initial value for the next linked command.

4.1.17 BUS DEVICE RESET Message (I→T)

Used by the initiator to direct the DVD-ROM drive to abort the current operation and to do reset. Upon receipt of this message, the DVD-ROM drive clears all operations for all initiators and shifts to BUS FREE phase. All status or message information are lost and the DVD-ROM drive performs the same operation as RESET condition (hard RESET alternative). For further details, refer to Section 3.2.2 RESET Condition.

4.1.18 IDENTIFY Message (I↔T)

Used by either the initiator or the DVD-ROM drive to establish the SCSI bus route between them. Table 4.6 shows the IDENTIFY message format.

	7	6	5	4	3	2	1	0
00	1	DiscPriv	LUNTAR	Reserved		LUNTRN		

Table 4.6: IDENTIFY Message

The DiscPriv (Disconnect Privilege) bit of one indicates that the initiator grants the DVD-ROM drive the privilege of disconnecting. The DiscPriv bit of **zero** indicates that the DVD-ROM drive shall not

perform disconnect. This bit is only defined for the initiator and it is set to **zero** when the DVD-ROM drive sends this message to the initiator. **LUNTAR**² bit is not used and shall be set to **zero**. **LUNTRN**³ field specifies a logical unit number. Regarding the response on **LUNTRN**, refer to Section 5.1.5 SELECTION of INVALID LOGICAL UNIT.

The initiator may send one or more **IDENTIFY** messages during a connection, however it should not send a second **IDENTIFY** message with a different value in **LUNTRN** field. (It is allowed to change **DiscPriv** bit.) If the DVD-ROM drive receives such invalid message, it goes to **BUS FREE** phase (unexpected disconnect).

Normally this message is used as shown in below.

1. Used by the initiator
During the **SELECTION** phase, the initiator asserts the $\overline{\text{ATN}}$ signal to request **MESSAGE OUT** phase. Then the DVD-ROM drive enters **MESSAGE OUT** phase and the initiator sends **IDENTIFY** message (**DiscPriv** bit set to one or zero).
2. Used by the DVD-ROM drive
The DVD-ROM drive sends **IDENTIFY** message (**DiscPriv** bit set to zero) during the **MESSAGE IN** phase following the **RESELECTION** phase. The initiator should restore the active pointers from the saved pointer upon receipt of this message. (Implied **RESTORE POINTERS**)

When the initiator is busy and it can not accept the reconnect request from the DVD-ROM drive , it can postpone the request by following procedure. (Toshiba unique)

1. The initiator asserts the $\overline{\text{ATN}}$ signal before the negation of the $\overline{\text{ACK}}$ signal of **IDENTIFY** message from the DVD-ROM drive .
2. The DVD-ROM drive enters **MESSAGE OUT** phase and the initiator sends **MESSAGE REJECT** message during this phase.
3. The DVD-ROM drive shifts to **BUS FREE** phase and then retries reconnect process later.

4.2 COMMENTS ON MESSAGE CONTROL

The mandatory message for initiator in SCSI-1 was **COMMAND COMPLETE** message. An initiator that supports only **COMMAND COMPLETE** message can control the DVD-ROM drive and SCSI-1 allows such initiator, while SCSI-2 requires that following message should be supported by the initiator.

COMMAND COMPLETE Message
INITIATOR DETECTED ERROR Message
MESSAGE REJECT Message
MESSAGE PARITY ERROR Message
IDENTIFY Message

The initiator indicates its ability to accommodate messages other than **COMMAND COMPLETE** by asserting $\overline{\text{ATN}}$ signal during **SELECTION** phase. The DVD-ROM drive indicates its ability by responding to this **ATTENTION** condition.

The first message sent by the initiator after **SELECTION** phase shall be **IDENTIFY**, **ABORT** or **BUS DEVICE RESET** message. If the first message is **IDENTIFY** message, it may be immediately followed by other messages such as **SYNCHRONOUS DATA TRANSFER REQUEST** message. If any other message is sent as first message, the DVD-ROM drive goes to **BUS FREE** phase immediately (unexpected disconnect). On the other hand, after **RESELECTION** phase, the DVD-ROM drive always sends **IDENTIFY** message to establish the physical path again. The DVD-ROM drive only sends **COMMAND COMPLETE**, **LINKED COMMAND COMPLETE** or **LINKED COMMAND COMPLETE WITH FLAG** message when the **IDENTIFY** message is not received.

Upon the detection of parity error, the DVD-ROM drive executes followings in accordance with the phase in which the parity error was detected.

²**LUNTAR**: Logical unit target

³**LUNTRN**: Logical unit number target routine number

1. MESSAGE OUT phase

The DVD-ROM drive continues to receive entire messages until the negation of the $\overline{\text{ATN}}$ signal and then re-asserts the $\overline{\text{REQ}}$ signal without changing the phase. The initiator shall transfer all messages same as previous and when re-sending multiple messages, it shall assert the $\overline{\text{ATN}}$ signal prior to the first $\overline{\text{ACK}}$ signal assertion. If this retry operation fails (i.e. detect parity error again), the DVD-ROM drive creates CHECK CONDITION status when the DVD-ROM drive knows the addressed LUN through IDENTIFY message or CDB at this moment. If the LUN is not known, the DVD-ROM drive goes to BUS FREE phase (unexpected disconnect).

2. COMMAND phase

When the IDENTIFY message is sent, the DVD-ROM drive shifts to MESSAGE IN phase and sends RESTORE POINTERS message and then creates COMMAND phase again. The initiator shall restore the command pointer and shall send the entire command same as previous. If retry operation fails, the DVD-ROM drive returns CHECK CONDITION status with additional sense code set to SCSI Parity Error. When the IDENTIFY message is not sent, the DVD-ROM drive goes to BUS FREE phase immediately since it is not allowed to send RESTORE POINTERS message and it does not know the LUN in this case.

3. DATA OUT phase

When the IDENTIFY message is sent, the DVD-ROM drive shifts to MESSAGE IN phase and sends RESTORE POINTERS message and then creates DATA OUT phase again. The initiator shall restore the data pointer and shall send the data again. If retry operation fails, the DVD-ROM drive returns CHECK CONDITION status with additional sense code set to SCSI Parity Error. When the IDENTIFY message is not sent, the DVD-ROM drive also returns CHECK CONDITION status since LUN is recognized through CDB.

Chapter 5

COMMAND

An operation request to the DVD-ROM drive is originated by a command transferred from the initiator to the DVD-ROM drive during the COMMAND phase. The DVD-ROM drive normally sends one status byte to the initiator after completion of the requested operation and this status byte indicates whether the command completed successfully or not. Especially when the CHECK CONDITION status is returned, the initiator can investigate the detailed error information by issuing the REQUEST SENSE command.

SCSI-2 (SCSI-1) defines reserved bits, field, bytes for each command respectively. The initiator shall issue a command with reserved bit set to **zero** and if the DVD-ROM drive receives a command in which reserved bit is not **zero**, it returns CHECK CONDITION status with sense key set to ILLEGAL REQUEST.

The command consists of several bytes called CDB (Command Descriptor Block). First byte of the CDB is a operation code which consists of a group code field and a command code field. The three bit group code specifies the group of command codes (eight groups) and it specifies the length of the CDB as well.

The Toshiba DVD-ROM drive supports following command groups.

- Group 0 command — Six bytes command
- Group 1 command — Ten bytes command
- Group 2 command — Ten bytes command
- Group 5 command — Twelve bytes command

Table 5.1 through 5.4 show the typical format of each command group.

	7	6	5	4	3	2	1	0
00	Operation Code							
	0	0	0					
01	LUN			Parameter Bit				
				(MSB)				
02	Logical Block Address (if required)							
03	(LSB)							
04	Transfer Length (if required)				Parameter List Length (if required)			
					Allocation Length (if required)			
05	Control Bytes							

Table 5.1: Group 0 Command Typical Format

	7	6	5	4	3	2	1	0
00	Operation Code							
	0	0	1					
01	LUN			Parameter Bit				
02	(MSB)							
03	Logical Block Address (if required)							
04								
05								(LSB)
06	Reserved							
07	(MSB)	Transfer Length or Parameter List Length						
08	Allocation Length (if Required)							(LSB)
09	Control Byte							

Table 5.2: Group 1 Command Typical Format

	7	6	5	4	3	2	1	0
00	Operation Code							
	0	1	0					
01	LUN			Parameter Bit				
02	(MSB)							
03	Logical Block Address (if required)							
04								
05								(LSB)
06	Reserved							
07	(MSB)	Transfer Length or Parameter List Length						
08	Allocation Length (if Required)							(LSB)
09	Control Byte							

Table 5.3: Group 2 Command Typical Format

	7	6	5	4	3	2	1	0
00	Operation Code							
	1	0	1					
01	LUN			Parameter Bit				
02	(MSB)							
03	Logical Block Address (if required)							
04								
05								(LSB)
06	Reserved							
07	(MSB)	Transfer Length or						
08	Parameter List Length or							
09	Allocation Length							
10	(if Required)							(LSB)
11	Control Byte							

Table 5.4: Group 5 Command Typical Format

Operation Code

The three bit are used for group code and five bit are used for command code. Thus eight groups and thirty-two codes are specified and a total of 256 operation codes exist.

Logical Unit Number

This field assigns an encoded identifier for the logical unit which is defined as a peripheral device addressable through the target. The DVD-ROM drive ignores the logical unit number specified in CDB if an IDENTIFY message was received. Since the SCSI controller of the DVD-ROM drive is embedded for each device, the DVD-ROM drive does not support the logical unit, so basically this field should be set to 000b.

Parameter Bit

Several commands use this field to specify unique function (usually reserved bits). For further details, refer to the description of individual commands.

Logical Block Address

This field indicates the logical block address defined for the DVD-ROM drive. Group 0 command (six-byte command) contains 21 bits addressing and group 1, 2, group 5 command (twelve-byte command) contains 32 bits addressing.

The definition is as follows.

The physical address of CD-ROM is subcode-Q address or CD-ROM header address which is called MSF address (Min, Sec, Frame). Since the initial 150 blocks (pre-gap area) are not accessible, 00:02:00 in physical expression is defined as the logical beginning of medium and defined as logical block **zero**. Also as several block lengths are available for the DVD-ROM drive, the logical block address is expressed as following formula. Regarding block length, refer to section 5.10 MODE SELECT command.

$$\text{LogicalBlockAddress} = (\text{Min} \times 60 \times 75 + \text{Sec} \times 75 + \text{Frame} - 150) \times \text{Block_Size}$$

Transfer Length

This field specifies the amount of data to be transferred between the initiator and the DVD-ROM drive, usually the number of logical blocks. However for several commands, this field has another definition, so see each command description for further information.

Up to 256 blocks can be assigned for six-byte command, and a value of **zero** indicates maximum 256 blocks.

Up to 65535 (FFFFh) blocks can be transferred by ten-byte command and up to 4294967295 (FFFFFFFFh) blocks can be assigned for twelve-byte command. In these commands that uses multiple bytes for transfer length, a transfer length of **zero** indicates that the command shall terminate immediately without error and no data shall be transferred.

Parameter List Length

This field indicates the number of bytes to be transferred during the DATA OUT phase. The length of **zero** indicates that no data shall be transferred.

Allocation Length

This field specifies the maximum number of bytes that the initiator has allocated for returned data to be transferred during DATA IN phase. An allocation length of **zero** indicates that no data shall be transferred. The DVD-ROM drive terminates the data transfer when allocation length bytes have been transferred or when all available bytes have been transferred, whichever is less.

Control Byte

This byte is the last byte of CDB and Table 5.5 shows its format.

	7	6	5	4	3	2	1	0
Last	Type		Reserved				FLAG	LINK

Table 5.5: Control Byte Format

Bit 0: Link

Link = 0: Indicates a single command or the last command in series of command linking.

Link = 1: Indicates a linking command.

The DVD-ROM drive goes to COMMAND phase to execute next linking command after sending INTERMEDIATE status when the current command completed successfully.

Bit 1: Flag

Flag bit specifies which message the DVD-ROM drive shall return when a linking command completes without error.

If the Link bit is set to **one**, the DVD-ROM drive sends one of following messages.

Link = 0 : LINKED COMMAND COMPLETE message

Link = 1 : LINKED COMMAND COMPLETE WITH FLAG message

Bit 6, 7: Type This field defined for vendor specific, Toshiba DVD-ROM drive does not use this field so should be set to **zero**.

5.1 OPERATION of DVD-ROM in SCSI

5.1.1 COMMAND OPERATION Type

All C/DVD-ROM SCSI commands are classified by the operation in SCSI system into following four groups, TYPE 1 through TYPE 4.

TYPE 1 : Operation which does not implement DISCONNECT and RECONNECT process during command execution and does not implement data transfer phase (DATA IN/OUT phase).

TYPE 2 : Operation which does not implement DISCONNECT and RECONNECT process during command execution and implements data transfer phase.

TYPE 3 : Operation which implements DISCONNECT and RECONNECT process during command execution and does not implement data transfer phase.

TYPE 4 : Operation which implements DISCONNECT and RECONNECT process during command execution and implements data transfer phase.

5.1.2 DISCONNECT and RECONNECT Process

The DVD-ROM drive may execute DISCONNECT and RECONNECT process if the initiator grants the privilege of disconnecting. DISCONNECT process means that the DVD-ROM drive goes to BUS FREE phase temporary when the DVD-ROM drive determines that there will be a delay to execute the requested command. On the contrary, RECONNECT process stands for that the DVD-ROM drive tries to reconnect the initiator to resume (complete) the suspended operation. Owing to these processes, the system throughput is improved since the SCSI bus becomes free and it allows other SCSI devices to use the bus.

The DVD-ROM drive executes following operations for DISCONNECT process.

1. Shifts to MESSAGE IN phase and sends DISCONNECT message to inform that current connection is going to be broken.

2. Releases the BSY signal and goes to BUS FREE phase.

The RECONNECT process is as follows.

1. Performs ARBITRATION phase and gains the control of SCSI bus.
2. Performs RESELECTION phase to reconnect the initiator.
3. Goes to MESSAGE IN phase and sends IDENTIFY message.

The initiator should restore the active pointers from the saved pointers upon receipt of this message. (implied RESTORE POINTERS) Note that the DVD-ROM drive executes DISCONNECT process when following conditions are met.

1. During SELECTION phase, the initiator identified its SCSI ID by setting the DATA BUS to a value which is the OR of its and target's SCSI ID.
2. The initiator sent IDENTIFY message with DISCPRIV bit set to **one**.
3. The DVD-ROM drive determines that there will be a delay such as READ command execution which requires physical head positioning.

Usually the DVD-ROM drive executes DISCONNECT process after COMMAND phase, however it may do DISCONNECT again after transferring a part of data. For instance, the DVD-ROM drive executes DISCONNECT process when the data buffer in the DVD-ROM drive becomes empty or when total amount of transferred data exceeds the specified maximum burst size. In this case, the DVD-ROM drive sends SAVE DATA POINTER message and DISCONNECT message sequentially and then goes to BUS FREE phase.

5.1.3 TYPE 4 Command Operation

Following shows an example of TYPE 4 command implementation.

1. The initiator performs ARBITRATION phase and gains the control of SCSI bus .
2. The initiator shifts to SELECTION phase and selects the DVD-ROM drive. Once the DVD-ROM drive is selected, the DVD-ROM drive controls the phase sequence of SCSI bus except ATTENTION and RESET condition.
3. During SELECTION phase, the initiator asserts the \overline{ATN} signal to inform the DVD-ROM drive that the initiator desires to send a message.
The DVD-ROM drive goes to MESSAGE OUT phase to respond to the ATTENTION condition and the initiator sends IDENTIFY message with DISCPRIV bit set to **one** to grant the privilege of disconnecting.
4. The DVD-ROM drive proceeds to COMMAND phase and receives command descriptor blocks (CDB) from the initiator.
5. The DVD-ROM drive shifts to MESSAGE IN phase and sends DISCONNECT message.
6. The DVD-ROM drive releases the BSY signal and goes to BUS FREE phase while it starts the operation requested by the command.
7. After the completion of the operation, the DVD-ROM drive performs ARBITRATION phase.
8. Winning the ARBITRATION phase, the DVD-ROM drive goes to RESELECTION phase to select the initiator.
9. The DVD-ROM drive goes to MESSAGE IN phase and sends IDENTIFY message.
The initiator should restore the active pointers from the saved pointers upon receipt of this message.

10. The DVD-ROM drive shifts to DATA IN phase and transfer required data. As mentioned in section 5.1.2 DISCONNECT and RECONNECT Process, the DVD-ROM drive may execute DISCONNECT process during data transfer.
11. The DVD-ROM drive goes to STATUS phase and returns status byte to the initiator. This status byte shows the results whether the command completed successfully or not.
12. The DVD-ROM drive shifts to MESSAGE IN phase and sends COMMAND COMPLETE message.
13. After sending the message, the DVD-ROM drive releases the $\overline{\text{BSY}}$ signal to create BUS FREE phase and terminates the operation of TYPE 4 command.

	Initiator	Direction	DVD-ROM drive	Phase
1)	Initiator's ID	→		ARBITRATION
	Initiator & DVD-ROM drive 's ID	→		SELECTION
2)	($\overline{\text{ATN}}$)	→		SELECTION
3)	IDENTIFY message	→		MESSAGE OUT
4)	COMMAND	→		COMMAND
5)		←	DISCONNECT message	MESSAGE IN
6)				BUS FREE
7)		←	Drive's ID	ARBITRATION
8)		←	Initiator & Drive's ID	RESELECTION
9)		←	IDENTIFY message	MESSAGE IN
10)		←	DATA	DATA IN
11)		←	STATUS	STATUS
12)		←	COMMAND COMPLETE message	MESSAGE IN
13)				BUS FREE

Table 5.6: TYPE 4 Command Operation Example

5.1.4 Linked Command Operation

The command link function provides a means to execute multiple commands successively and also relative addressing is available for a linking command. Upon the completion of current linked command, the DVD-ROM drive automatically proceeds to COMMAND phase to execute next linked command. LINKED COMMAND COMPLETE or LINKED COMMAND COMPLETE WITH FLAG message is sent to the initiator to indicates that a linked command completes successfully.

If a linked command does not complete successfully, the DVD-ROM drive executes followings.

1. Goes to STATUS phase and sends CHECK CONDITION status instead of INTERMEDIATE status.
2. Goes to MESSAGE IN phase and sends COMMAND COMPLETE message regardless of the FLAG bit.
3. Goes to BUS FREE phase and does not execute subsequent linking command.

Following shows an example of linked command (two TYPE 1 command) implementation.

1. The initiator performs ARBITRATION phase and gains the control of SCSI bus .
2. The initiator shifts to SELECTION phase and selects the DVD-ROM drive. Once the DVD-ROM drive is selected, the DVD-ROM drive controls the phase sequence of SCSI bus except ATTENTION and RESET condition.
3. During SELECTION phase, the initiator asserts the $\overline{\text{ATN}}$ signal to inform the DVD-ROM drive that the initiator desires to send a message. The DVD-ROM drive goes to MESSAGE OUT phase to respond the ATTENTION condition and the initiator sends IDENTIFY message with DISCPRIV bit set to **one** to grant the privilege of disconnecting.

4. The DVD-ROM drive proceeds to COMMAND phase and receives command descriptor blocks (CDB) from the initiator.
Suppose the Link bit in CDB is set to **one** in this case.
5. The DVD-ROM drive starts the operation requested by the command.
6. Upon completing the command successfully, the DVD-ROM drive goes to STATUS phase and returns INTERMEDIATE status byte to the initiator.
7. The DVD-ROM drive shifts to MESSAGE IN phase and sends LINKED COMMAND COMPLETE or LINKED COMMAND COMPLETE WITH FLAG message.
The initiator should update the pointers and set to the initial value for next linked command upon receipt of this message.
8. After sending message, the DVD-ROM drive proceeds to COMMAND phase again and receives next CDB from the initiator.
Suppose the Link bit is set to **zero** in this case.
9. The DVD-ROM drive starts the operation requested by the command.
10. Upon completing the command, the DVD-ROM drive goes to STATUS phase again and returns status byte to the initiator. This status byte shows the results whether the command completed successfully or not.
11. The DVD-ROM drive shifts to MESSAGE IN phase and sends COMMAND COMPLETE message which indicates that the execution of command chain completes.
12. After sending the message, the DVD-ROM drive releases the $\overline{\text{BSY}}$ signal to create BUS FREE phase and terminates the operation of linked commands.

5.1.5 Selection of Invalid Logical Unit

As the DVD-ROM drive does not support the logical unit, the logical unit number other than **zero** is invalid basically. In response to INQUIRY command, the DVD-ROM drive executes the command and returns INQUIRY data with the peripheral qualifier/device type field set to 7Fh. In response to REQUEST SENSE command, the DVD-ROM drive executes the command and returns sense data of additional sense code set to LOGICAL UNIT NOT SUPPORTED. In response to other commands, the DVD-ROM drive returns CHECK CONDITION status and does not execute the command.

5.1.6 UNIT ATTENTION CONDITION

The DVD-ROM drive generates unit attention condition whenever one of following events occurs.

1. The DVD-ROM drive has been reset by power-on reset, RESET condition or BUS DEVICE RESET message.
2. The MODE SELECT parameters (block length and/or page parameters) for the initiator have been changed by another initiator.
3. Medium may have been changed.
4. Command execution timer expired. (See Section 5.13.8 pp.63)

If a unit attention condition occurs before the previous unit attention condition is cleared, the previous unit attention condition is queued. Then the unit attention condition will be reported in following order of significance.

1. Medium changed (6/28/00)
2. Power-on or RESET condition (6/29/00)

3. Insufficient Time for Operation (6/2E/00)
4. Operating Conditions Have Changed (6/3F/00)

The unit attention condition is persisted for each initiator until that initiator clears the condition. When command is issued under pending unit attention condition, the DVD-ROM drive performs following operations.

1. **INQUIRY, GET CONFIGURATION and GET EVENT STATUS NOTIFICATION** command
Performs the command and does not clear the unit attention condition
2. **REQUEST SENSE** command
Report the unit attention sense key with appropriate additional sense code/qualifier and clears the unit attention condition.
3. Command other than **INQUIRY, GET CONFIGURATION, GET EVENT STATUS NOTIFICATION and REQUEST SENSE**
Reports **CHECK CONDITION** status and does not execute the command unless higher priority status exists.

When command is issued after the DVD-ROM drive returns **CHECK CONDITION** status, the DVD-ROM drive performs following operations.

1. **INQUIRY, GET CONFIGURATION and GET STATUS EVENT NOTIFICATION** command
Clear the unit attention condition and executes the command.
2. **REQUEST SENSE** command
Report the unit attention sense key with appropriate additional sense code/qualifier and clears the unit attention condition.
3. Command other than **INQUIRY and REQUEST SENSE** commands
4. Command other than **INQUIRY, GET CONFIGURATION, GET STATUS EVENT NOTIFICATION and REQUEST SENSE**
Clears the unit attention condition and performs the command if no other unit attention condition is pending.

5.2 UN-SUPPORTED COMMANDS

Toshiba CD-ROM drive supported **No Operation, Verify, Pre-Fetch, Read Buffer, Play Audio Track/Index, Play Audio Track Relative** and all of Toshiba CD-ROM Vendor Unique commands are not implemented on Toshiba DVD-ROM drive.

5.3 LIST OF COMMANDS

CODE	COMMAND DESCRIPTION	MEDIA TYPE		EXECUTE TYPE	REFERENCE	
		CD	DVD		SECTION	PAGE
<i>Group 0</i>						
00h	Test Unit Ready	Mandatory		1	§5.4	<i>pp.</i> 32
01h	Rezero Unit	Option	Vendor	3	§5.5	<i>pp.</i> 33
03h	Request Sense	M		2	§5.6	<i>pp.</i> 34
08h	Read(6)	O	V	4	§5.7	<i>pp.</i> 36
0Bh	Seek(6)	O	V	3	§5.8	<i>pp.</i> 37
12h	Inquiry	M		2	§5.9	<i>pp.</i> 38
15h	Mode Select(6)	O	V	2	§5.10	<i>pp.</i> 42
16h	Reserve	M		1	§5.11	<i>pp.</i> 49
17h	Release	M		1	§5.12	<i>pp.</i> 51
1Ah	Mode Sense(6)	O	V	2	§5.13	<i>pp.</i> 52
1Bh	Start/Stop Unit	M		3	§5.14	<i>pp.</i> 70
1Ch	Receive Diagnostics Results	O		2	§5.15	<i>pp.</i> 72
1Dh	Send Diagnostic	M		3	§5.16	<i>pp.</i> 73
1Eh	Prevent/Allow Medium Removal	M		1	§5.17	<i>pp.</i> 75
<i>Group 1</i>						
23h	Read Formatted Capacity	M		2	§5.18	<i>pp.</i> 76
25h	Read C/DVD Capacity	M		2	§5.19	<i>pp.</i> 78
28h	Read(10)	M	O	4	§5.20	<i>pp.</i> 80
2Bh	Seek(10)	M		3	§5.21	<i>pp.</i> 81
3Bh	Write Buffer	O		3	§5.22	<i>pp.</i> 82
<i>Group 2</i>						
42h	Read Sub-Channel	M	—	2	§5.23	<i>pp.</i> 83
43h	Read TOC/PMA/ATIP	M	V	2	§5.24	<i>pp.</i> 88
44h	Read Header	M	—	4	§5.25	<i>pp.</i> 95
45h	Play Audio(10)	O	—	3	§5.26	<i>pp.</i> 97
46h	Get Configuration	M		2	§5.27	<i>pp.</i> 98
47h	Play Audio MSF	O	—	3	§5.28	<i>pp.</i> 112
4Ah	Get Event Status Notification	M		2	§5.29	<i>pp.</i> 113
4Bh	Pause/Resume	O	—	1	§5.30	<i>pp.</i> 120
4Eh	Stop Play/Scan	O	—	1	§5.31	<i>pp.</i> 121
51h	Read Disc Information	M		4	§5.32	<i>pp.</i> 122
52h	Read Track Information	M		4	§5.33	<i>pp.</i> 126
55h	Mode Select(10)	O	M	2	§5.34	<i>pp.</i> 130
5Ah	Mode Sense(10)	O	M	2	§5.35	<i>pp.</i> 131
<i>Group 5</i>						
A2h	Send Event	M		2	§5.36	<i>pp.</i> 132
A3h	Send Key	—	M	2	§5.37	<i>pp.</i> 134
A4h	Report Key	—	M	2	§5.38	<i>pp.</i> 138
A5h	Play Audio(12)	O	—	3	§5.39	<i>pp.</i> 143
A7h	Set Read Ahead	M		1	§5.40	<i>pp.</i> 144
A8h	Read(12)	O	M	4	§5.41	<i>pp.</i> 145
ACh	Get Performance	M		2	§5.42	<i>pp.</i> 146
ADh	Read DVD Structure	—	M	4	§5.43	<i>pp.</i> 148
B6h	Set Streaming	M		3	§5.44	<i>pp.</i> 155
B9h	Read CD MSF	M	—	4	§5.45	<i>pp.</i> 157
BAh	Scan	O	—	1	§5.46	<i>pp.</i> 159
BBh	Set CD Speed	O	V	1	§5.47	<i>pp.</i> 161
BDh	Mechanism Status	M		2	§5.48	<i>pp.</i> 162
BEh	Read CD	M	V	4	§5.49	<i>pp.</i> 163

Table 5.7: List of COMMANDS

5.4 TEST UNIT READY command

	7	6	5	4	3	2	1	0	NOTE
00	Operation Code								00h
01	LUN								00h
02									00h
03	Reserved								00h
04									00h
05							Flag	Link	
06									—
07									—
08	PAD								—
09									—
10									—
11									—

COMMAND FUNCTION

Check if the drive is ready, however, this command is not to request for self test.

< Command Type > : Mandatory (Core)

DESCRIPTION

When the DVD-ROM drive is in READY status, the DVD-ROM drive returns GOOD status to this command.

When the DVD-ROM drive is in IDLE status, it returns CHECK CONDITION status with an appropriate sense key.

READY status : Tray with medium is loaded correctly and the DVD-ROM drive can accept an appropriate medium-access command without returning CHECK CONDITION status.

IDLE status : Other than READY status

5.5 REZERO command

	7	6	5	4	3	2	1	0	NOTE	
00	Operation Code								01h	
01	LUN									00h
02									00h	
03	Reserved								00h	
04									00h	
05							Flag	Link		
06									—	
07									—	
08	PAD								—	
09									—	
10									—	
11									—	

COMMAND FUNCTION

Turn off the laser, stop the spindle motor and move the pickup head to the innermost bound and enter standby mode.

< Command Type > : Optional

DESCRIPTION

Turn off the laser, stop the spindle motor and move the pickup head to the innermost bound.

Note that the DVD-ROM drive only accepts this command when it is in READY condition. The DVD-ROM drive returns a CHECK CONDITION status for this command when the DVD-ROM drive is not READY such as when Tray/Drawer is opened.

5.6 REQUEST SENSE command

	7	6	5	4	3	2	1	0	NOTE
00	Operation Code								03h
01	LUN								00h
02	Reserved								00h
03									00h
04	Allocation Length								
05	Reserved					Flag	Link		
06									—
07									—
08	PAD								—
09									—
10									—
11									—

COMMAND FUNCTION

Request the drive to transfer sense data to the Host Computer.

< Command Type > : Mandatory

< Allocation Length > : Maximum number of bytes that the Host Computer has allocated for returned sense data.

DESCRIPTION

This command requests the DVD-ROM drive to transfer the sense data held in the DVD-ROM drive to the Host Computer that is related the command resulting in a **CHECK CONDITION** status. The sense data is preserved until receiving a **REQUEST SENSE** command or until receipt of any other command.

The DVD-ROM drive only returns a **CHECK CONDITION** status to report fatal errors during the execution of the **REQUEST SENSE** command.

When this command is issued with no valid sense data, sense data with **NO SENSE** sense key is transferred.

Note: That NO SENSE sense key but with appropriate additional sense code qualifier which shows the play operation status may be returned during audio playback operation.

The allocation length field specifies the maximum number of bytes that the Host Computer has allocated for returned sense data to be sent during the data transfer phase. The DVD-ROM drive terminates the data transfer when allocation length bytes have been transferred or when all available sense data have been transferred to the Host Computer, whichever is less.

Namely followings are transferred to the Host Computer;

ALLOCATION LENGTH	EFFECT
00d	No sense data is transferred and the command terminates immediately with out error.
01d to 17d	Specified bytes from top of the sense data
18d or greater	All sense data consisting of 18 bytes

The drive supports extended sense data format (Error code = 70h or 71h), 18 bytes long.

Error code 71h (Deferred error) indicates that the error is not due to the current command and it is used to report the error termination of audio playback operation due to background **PLAY AUDIO** commands. Audio playback operation continues and may complete without notification to the Host Computer, however if the audio playback stops due to error, the DVD-ROM drive

returns a CHECK CONDITION status to the next command (except for REQUEST SENSE, INQUIRY and GET EVENT STATUS NOTIFICATION command).

Deferred error code is used to indicate such condition.

For more details on the sense data, refer to Chapter 6 **SENSE DATA**. pp.167

	7	6	5	4	3	2	1	0	NOTE
00	Valid	Error Code (70h or 71h)							
01	Segment Number (Reserved)								00h
02	Reserved	ILI	Reserved	Sense Key					
03	(MSB)	Information							
04									
05									
06								(LSB)	
07	Additional Sense Length (=0Ah)								0Ah
08	(MSB)	Command Specific Information							
09									
10									
11								(LSB)	
12	Additional Sense Code								ASC
13	Additional Sense Code Qualifier								ASCQ
14	Field Replaceable Unit Code								00h
15	SKSV	Sense-Key Specific							
16									
17									

Table 6.1: Sense Data Format (pp.167)

5.7 READ(6) command

	7	6	5	4	3	2	1	0	NOTE
00	Operation Code								08h
01	LUN			(MSB)					
02	Logical Block Address								
03	(LSB)								
04	Transfer Length								
05	Reserved						Flag	Link	
06									—
07									—
08	PAD								—
09									—
10									—
11									—

COMMAND FUNCTION

Request the DVD-ROM drive to transfer read data specified by the logical block address and transfer length field to the initiator.

The DVD-ROM drive supports this command for use old device driver, that based on CD-ROM.

< Command Type > : Optional

< Logical Block Address > : The logical block address at which the read operation shall begin.

< Transfer Length > : The number of logical block to be transferred.

DESCRIPTION

This command requests the DVD-ROM drive to transfer data specified by logical block address and transfer length field to the initiator.

This command is available for all density codes including CD-DA transfer mode.

Logical Block Address field specifies the logical block address at which the read operation shall begin.

If the density code is other than 82/84h(CD-DA transfer mode), and if the requested logical block is not data track, the DVD-ROM drive terminates the command and returns **CHECK CONDITION** status.

If the density code is 82/84h, and if the requested logical block is not audio CD track, the DVD-ROM drive terminates the command and returns **CHECK CONDITION** status.

For both case, the sense key is set to **BLANK CHECK** and the additional sense code is set to **ILLEGAL MODE FOR THIS TRACK**.

This command can not specify up to 2097151d(1FFFFFFh) blocks of Logical Block Address and it covers entire address of one CD (CD-ROM) medium.

Transfer Length field specifies the number of contiguous logical blocks of data that are transferred during DATA IN phase. A transfer length of **zero** indicates that 256 logical blocks shall be transferred.

The transfer data format (Block Length, CD-ROM XA selection etc.) or error recovery parameters are specified by the **MODE SELECT** command issued prior to the **READ** command. Regarding these parameters, refer to Section 5.10 **MODE SELECT** command.

5.8 SEEK(6) command

	7	6	5	4	3	2	1	0	NOTE	
00	Operation Code								0Bh	
01	LUN			(MSB)						
02	Logical Block Address									
03									(LSB)	
04	Reserved								00h	
05							Flag	Link		
06									—	
07									—	
08	PAD								—	
09									—	
10									—	
11									—	

COMMAND FUNCTION

Request the DVD-ROM drive to seek to the specified logical block address.

< Command Type > : Optional

< Logical Block Address > : Specifies the logical block address at which the seek operation is executed.

DESCRIPTION

This command requests the DVD-ROM drive to seek to the specified logical block address.

All logical block addresses are able to be targets for a SEEK operation including a CD-DA audio sector.

In the case of C/DVD-ROM data sector (Density code is other than 82h/84h), the seek operation of DVD-ROM drive completes when the optical head reaches within 1 track to the specified address, that is similar definition to the hard disk drive (On track condition).

In the case of CD-DA audio sector (Density code is 82h or 84h), the DVD-ROM drive seek operation completes when the specified address is found.

The Logical Block Address field specifies the logical block address at which the seek operation is executed.

5.9 INQUIRY command

	7	6	5	4	3	2	1	0	NOTE
00	Operation Code								12h
01	LUN			Reserved			CmdDt	EVPD	00h
02	Page Code								00h
03	Reserved								00h
04	Allocation Length								
05	Reserved					Flag	Link		
06									—
07									—
08	PAD								—
09									—
10									—
11									—

COMMAND FUNCTION

Transfer the INQUIRY data that is the information regarding several parameters of the drive to the host.

< Command Type > : Mandatory (Core)

< CmdDt > : CmdDt¹ bit is not support, should be set to **zero**.

< EVPD > : EVPD² bit is not support, should be set to **zero**.

< Page Code > : Not support, should be set to **zero**.

< Allocation Length > : Maximum number of bytes that the Host Computer has allocated for the returned INQUIRY data.

DESCRIPTION

This command requests the DVD-ROM drive to transfer standard INQUIRY data which shows the attribute of the drive. The INQUIRY data of the DVD-ROM drive consists of 96 bytes and the transferred length is specified by the allocation length field. The DVD-ROM drive terminates the data transfer when the allocation length bytes have been transferred or when all available data have been transferred to the Host Computer, whichever is less.

That is, followings are transferred to the Host Computer;

ALLOCATION LENGTH	EFFECT
00d	No INQUIRY data is transferred and the command terminates immediately without error
01d to 96d	Specified bytes from top of the INQUIRY data
97d or greater	All INQUIRY data consisting of 96 bytes

If this command is received from the Host Computer with a pending unit attention condition, the DVD-ROM drive performs the INQUIRY command and does not clear the unit attention condition.

¹CmdDt : Command Support Data

²EVPD: Enable Vital Product Data

Table 5.8 shows the standard INQUIRY data format of the drive.

	7	6	5	4	3	2	1	0	NOTE
00	Peripheral Qualifier			Peripheral Device Type					05/7Fh
01	RMB	Reserved							80h
02	ISO Version		ECMA Version		ANSI Approved Version				02h
03	AERC	TrmTSK	NormACA	HiSupport	Response Data Format				02h
04	Additional Length(=91d)								5Bh
05	SCCS	Reserved							00h
06	BQue	EncServ	Reserved	MultiP	MChngr	AckReqQ	Addr32	Addr16	00h
	0	0	0	0	0	0	0	0	
07	RelAdr	WBus32	WBus16	Sync	Linked	Reserved	CmdQue	SftRe	18h
	0	0	0	1	1	0	0	0	
08	(MSB)								
⋮	Vender Identification (in ASCII)								⋮
15								(LSB)	
16	(MSB)								
⋮	Product Identification (in ASCII)								⋮
31								(LSB)	
32	(MSB)								
⋮	Product Revision Level (in ASCII)								⋮
35								(LSB)	
36	(MSB)								
⋮	Firmware Date (in ASCII)								⋮
43								(LSB)	
44									⋮
⋮	Vender Specification								00h
55									⋮
56									
⋮	Reserved								00h
95									

Table 5.8: Inquiry Data Format

Byte 00 : Peripheral Device Type/Qualifier

Bit 7 - 5 : Qualifier

000b — Indicates currently connected.

011b — Indicates not capable of supporting a physical device on this drive.

Bit 4 - 0 : Device Type

05h — Indicates CD-ROM device type.

1Fh — Indicates that the DVD-ROM drive does not support logical unit.

Byte 01 :

Bit 7 : RMB(Removal Medium) bit

1b — Indicates medium is removable.

Byte 02 : Versions

Bit 7 - 6 : ISO(International Organization for Standardization) versions

00b — Indicates not supported.

- Bit 5 - 3** : ECMA(European Computers Association) versions
000b — Indicates not supported.
- Bit 2 - 0** : ANSI Version
2h — Indicates that the implemented version of SCSI-2.
- Byte 03** : Command/Data Format
- Bit 7** : AERC(Asynchronous event reporting capability) bit
0b — This bit indicates a reporting capability as defined in SAM.
- Bit 6** : TrmTsk(Terminate Task) bit
0b — Indicates that the DVD-ROM drive does not support the task management function.
- Bit 5** : NormACA(Normal ACA) bit
0b — Indicates that the DVD-ROM drive does not support setting the NACA bit to **one**.
- Bit 4** : HiSupport(Hierarchical Support) bit
0b — Indicates that the DVD-ROM drive does not use the hierarchical addressing model to assign LUNs.
- Bit 3 - 0** : Response Data Format
2h — Indicates that the data is in the format specified in SCSI-2.
- Byte 04** : Additional Length
5Bh — Specifies the length in bytes of the parameters to be followed.
- Byte 05** :
- Bit 7** : BQue(Basic Queuing) bit
0b — Indicates that the DVD-ROM drive does not support tagged tasks.
- Bit 6** : EncServ(Enclosure Services) bit
0b — Indicates that the DVD-ROM drive does not contain an embedded enclosure services component.
- Bit 4** : MultiP(Multi Port) bit
0b — Indicates that the DVD-ROM drive has a single port and does not implement the multi-port requirements.
- Bit 3** : MChngr(Medium Changer) bit
0b — Indicates that the DVD-ROM drive is not embedded within or attached to a medium transport element.
- Bit 2** : AckReqQ(ACKQ/REQQ) bit
0b — Indicates that the DVD-ROM drive does not support a request and acknowledge data transfer handshake on the secondary bus.
- Bit 1** : Addr32(Wide SCSI Address 32) bit
0b — Indicates that the DVD-ROM drive does not support 32-bit wide SCSI addresses.
- Bit 0** : Addr16(Wide SCSI Address 16) bit
0b — Indicates that the DVD-ROM drive does not support 16-bit wide SCSI addresses.
- Byte 06** :
- Bit 7** : RelAdr(Relative Addressing) bit
0b — Indicates that the DVD-ROM drive does not support relative addressing function.
- Bit 6** : WBus32(Wide Bus 32) bit
0b — The DVD-ROM drive does not support 32-bit wide data transfer.
- Bit 5** : WBus16(Wide Bus 16) bit
0b — The DVD-ROM drive does not support 16-bit wide data transfer.
- Bit 4** : Sync(Synchronous Transfer) bit
1b — Indicates that the DVD-ROM drive supports synchronous data transfer.
- Bit 3** : Linked(Linked Command) bit
1b — Indicates that the DVD-ROM drive supports command link function.

Bit 2 : TranDis(Transfer Disable) bit

0b — Indicates that the DVD-ROM drive does not support one or both of CONTINUE TASK, TARGET TRANSFER DISABLE messages.

Bit 1 : CmdQue(Command Queuing) bit

0b — Indicates that the DVD-ROM drive does not support this feature.

Bit 0 : SftRe(Soft Reset) bit

0b — Indicates that the DVD-ROM drive responds to the RESET condition with hard reset alternative.

Byte 08 - 15 : Vendor Identification

This field contains eight bytes of ASCII data identifying the vendor of the product.

BYTE	08	09	10	11	12	13	14	15
ASCII	T	O	S	H	I	B	A	
CODE	54h	4Fh	53h	48h	49h	42h	41h	20h

Byte 16 - 31 : Product Identification

This field contains sixteen bytes of ASCII data identifying the product.

BYTE	16	17	18	19	20	21	22	23	24	25	26	27	28	29	30	31
ASCII	D	V	D	-	R	O	M		S	D	-	M	1	4	0	1
CODE	44h	56h	44h	2Dh	52h	4Fh	4Dh	20h	53h	44h	2Dh	4Dh	31h	34h	30h	31h

Byte 32 - 35 : Product Revision Level

This field contains four bytes of ASCII data identifying the revision of the product.

BYTE	32	33	34	35
ASCII	Θ	Ψ	Φ ₁	Φ ₂
CODE	??	??	??	??

Where:

Θ : Major Version
 Φ₁Φ₂ : Minor Version
 Ψ : Customize Version

Byte 36 - 43 : SCSI Firmware Data (Vendor Unique)

This field contains eight bytes of ASCII data identifying the created date of the firmware.

BYTE	36	37	38	39	40	41	42	43
ASCII	<i>m</i> ₁	<i>m</i> ₂	/	<i>d</i> ₁	<i>d</i> ₂	/	<i>y</i> ₁	<i>y</i> ₂
CODE	??	??	2Fh	??	??	2Fh	??	??

Where:

*m*₁*m*₂ : month
*d*₁*d*₂ : day
*y*₁*y*₂ : year

5.10 MODE SELECT(6) command

	7	6	5	4	3	2	1	0	NOTE
00	Operation Code								15h
01	LUN			PF				SP	10h(/00h)
02	Reserved								00h
03									00h
04	Parameter List Length								
05	Reserved						Flag	Link	
06									—
07									—
08	PAD								—
09									—
10									—
11									—

COMMAND FUNCTION

Provides a means for the Host Computer to specify following parameters.

- Block Descriptor (Density Code and Block Length)
- Page 01 (Error Recovery parameters)
- Page 02 (Disconnect/Reconnect Control parameters)
- Page 0D (CD-ROM parameters)
- Page 0E (Audio Control parameters)
- Page 1A (Power Condition Mode parameters)
- Page 1D (C/DVD Time-out & Protect parameters)
- Page 20 (Obsolete)

< Command Type > : Optional

<Parameter List Length > : This field specifies the length in bytes of the MODE SELECT parameter list that is transferred from the Host Computer.

< PF > : Page Field (if required should be set to **one**, else should be set Parameter List Length fields are **zero**)

< SP > : Save Pages function is not supported (should be set to **zero**).

DESCRIPTION

This command is used to specify above-mentioned parameters. As the DVD-ROM drive also supports a MODE SENSE command, the Host Computer can examine the supported pages, page length etc. by issuing a MODE SENSE command prior to a MODE SELECT command.

Note: That the Capability and Mechanical Status Page is read only and is not changeable with a MODE SELECT command. As the DVD-ROM drive does not support the saving pages function, it returns a CHECK CONDITION status when the SP bit is set to one.

The parameter list length field specifies the length in bytes of the MODE SELECT parameter list that is transferred. A parameter list length of **zero** indicates that no data is transferred and the command terminates immediately. (Any parameter is not changed.)

The MODE SELECT parameter list (Table 5.9) contains eight bytes mode parameter header, followed by **zero** or more pages.

	7	6	5	4	3	2	1	0	NOTE
00	Reserved								00h
01	Medium Type								00h
02	Drive Specific Parameter								00h
03	Block Description Length								00/08h
	<i>Block Descriptor(s)</i>								
00	Density Code								
01	(MSB)								00h
02	Number of Blocks								00h
03							(LSB)	00h	
04	Reserved								00h
05	(MSB)								00h
06	Block Length								
07							(LSB)		
	<i>Page Descriptor(s)</i>								
00	PS(0)	Reserved	Page Code						
01	Page Length								
02									
⋮	Page Parameter (refer to each pages)								⋮
NN									

Table 5.9: Mode Select(6) parameter list

5.10.1 Mode Parameter Header

Byte 00 : Mode Data Length, **Byte 01**: Medium Type

These fields are for a **MODE SENSE** command and are reserved for a **MODE SELECT** command (should be set to **zero**).

Byte 02 : Device Specific Parameter

00h - All bits (WP, Cache, EBC) are reserved.

Byte 03 : Block Descriptor Length

This field specifies the length in bytes of all block descriptors. Valid block descriptor length of the DVD-ROM drive are either 00h or 08h.

00h shows that the block descriptor is not included in the parameter list. If other length is specified, **CHECK CONDITION** status is reported.

5.10.2 Block Descriptor(s)

Byte 00 : Density Code

This field specifies the error detection/correction mode to distinguish CD-ROM Yellow book mode from the CD-ROM XA mode and allows the transfer of CD-DA digital audio data through SCSI.

CD-ROM XA track is recorded in compliance with CD-ROM Mode-2 format and one sector (2352 bytes) consists of Sync (12 bytes), Header (4 bytes), Subheader (8 bytes) and Data field (2328 bytes).

Two Forms (Form-1 and Form-2) are defined just as Mode-1 and Mode-2 of Yellow book.

ECC³ is available from Form-1 format and it will be used as data sectors, compressed video sectors, while Form-2 format is used as ADPCM audio sectors and/or video sectors.

³ECC: Error Correction Code

The definition of density code is as follows.

82h: CD-DA transfer over SCSI support mode. (Audio output muted)

CD-DA digital audio data along with subcode-Q address or subcode R thru W data is available through the SCSI interface with `READ(6)`, `Read(10)` and `Read(12)` command.

The DVD-ROM drive uses CIRC based algorithm of CD audio level and CD-DA error compensation such as interpolation is applied to the data if necessary, just as CD-DA digital audio reproduction from analog output (headphone) of the DVD-ROM drive.

Audio output from DAC⁴ is muted.

When CD-ROM sector including CD-ROM XA sector is read, the DVD-ROM drive returns `CHECK CONDITION` status with additional sense code set to `ILLEGAL MODE FOR THIS TRACK`.

84h: CD-DA transfer over SCSI support mode. (Audio output enabled)

Same data as the density code of 82h is available through the SCSI interface with `READ(6)`, `Read(10)` and `Read(12)` command.

Audio output from DAC is enabled while transferring same data over SCSI.

Others: Data sector data transfer over SCSI support mode.

Byte 05 -07 : Block Length

This field specifies the length in bytes of each logical block when the data is transferred to the initiator by the execution of `READ(6)`, `READ(10)` and `READ(12)` command.

Following show the available combination of the density code and block length. If any other combination is specified, `CHECK CONDITION` status is returned.

The default density code and block length is 00h/2048d(800h) that is equivalent to either Mode-1, Form-1 or DVD user data transfer mode.

Density Code 82/84h, Block Length = 16d(10h)

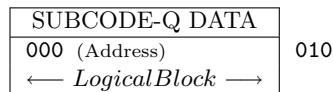

Where;

SUBCODE-Q DATA: This field has one of following three format (Table 5.10 to 5.12) depended upon the subcode-Q address data format (Mode).

Mode-1 is address data in which track number, index number, running time within a track and running time on the disc (ATIME) is included. Mode-1 data occupies at least 9 out of 10 successive subcode blocks.

Optional format of Mode-2 gives the catalog number of the disc (UPC/EAN code) and it occupies at least 1 out of 100 successive subcode blocks, if used.

Optional format of Mode-3 gives the International Standard Recording Code (ISRC) for each track and it occupies at least 1 out of 100 successive subcode blocks, if used.

For future details on the subcode-Q address data format, refer to IEC 908 which describes the compact disc digital audio system.

Density Code 82/84h, Block Length = 96d(60h)



Where;

SUBCODE P-W DATA: Excluding synchronization byte (2 bytes), 96 bytes are transferred per each subcode frame.

Subcode-P field is a pause flag that indicates the starting point of each track.

⁴**DAC:** Digital to Analog Converter

OFFSET	DESCRIPTION
2352(930h)	Control Filed (4 bit, leading zero)
2353(931h)	Subcode-Q Mode (01h)
2354(932h)	Track Number (TNO)(BCD)
2355(933h)	Track Number (X)(BCD)
2356(934h)	Time Data (Minutes)(BCD)
2357(935h)	Time Data (Second)(BCD)
2358(936h)	Time Data (Frames)(BCD)
2359(937h)	Absolute Time Data (Minutes)(BCD)
2360(938h)	Absolute Time Data (Second)(BCD)
2361(939h)	Absolute Time Data (Frames)(BCD)
2362(93Ah)	Don't care
2363(93Bh)	Don't care
2364(93Ch)	Don't care
2365(93Dh)	Don't care
2366(93Eh)	Don't care
2367(93Fh)	Don't care

Table 5.10: Subcode-Q Field (Mode-1)

OFFSET	DESCRIPTION
2352(930h)	Control Filed (4 bit, leading zero)
2353(931h)	Subcode-Q Mode (02h)
2354(932h)	Catalog Number N1 (BCD, leading zero)
2355(933h)	Catalog Number N2 (BCD, leading zero)
2356(934h)	Catalog Number N3 (BCD, leading zero)
2357(935h)	Catalog Number N4 (BCD, leading zero)
2358(936h)	Catalog Number N5 (BCD, leading zero)
2359(937h)	Catalog Number N6 (BCD, leading zero)
2360(938h)	Catalog Number N7 (BCD, leading zero)
2361(939h)	Catalog Number N8 (BCD, leading zero)
2362(93Ah)	Catalog Number N9 (BCD, leading zero)
2363(93Bh)	Catalog Number N10 (BCD, leading zero)
2364(93Ch)	Catalog Number N11 (BCD, leading zero)
2365(93Dh)	Catalog Number N12 (BCD, leading zero)
2366(93Eh)	Catalog Number N13 (BCD, leading zero)
2367(93Fh)	Absolute Time (Frames)(BCD)

Table 5.11: Subcode-Q Field (Mode-2)

Subcode-Q field contains the information of address data or the UPC/EAN code or the ISRC code.

Subcode-R-W is defined for display purpose and the subcode graphics (Mode 1 and 2) and the MIDI⁵ format (Mode-3) has been defined so far.

Earch group of 6 bits (R thru W) is called a SYNBOL and a PACK consisting of 24 SYMBOLS contains a Mode , Item, Instruction (subcode graphics) or Byte (MIDI), Data and P/Q-Parity. READ-SOLOMON code is used for P/Q-Parity and the interleave is applied for error protection.

The host system has no apply de-interleave (Maximum 7 PACKs) and error correction/detection if necessary.

For details, refer to the each specification.

⁵MIDI: Musical Instrument Digital Interface

OFFSET	DESCRIPTION
2352(930h)	Control Filed (4 bit, leading zero)
2353(931h)	Subcode-Q Mode (03h)
2354(932h)	Country Code I1 (6 bits, leading zero)
2355(933h)	Country Code I2 (6 bits, leading zero)
2356(934h)	Country Code I3 (6 bits, leading zero)
2357(935h)	Country Code I4 (6 bits, leading zero)
2358(936h)	Country Code I5 (6 bits, leading zero)
2359(937h)	Serial Number I6 (6 bits, leading zero)
2360(938h)	Serial Number I7 (BCD, leading zero)
2361(939h)	Serial Number I8 (BCD, leading zero)
2362(93Ah)	Serial Number I9 (BCD, leading zero)
2363(93Bh)	Serial Number I10 (BCD, leading zero)
2364(93Ch)	Serial Number I11 (BCD, leading zero)
2365(93Dh)	Serial Number I12 (BCD, leading zero)
2366(93Eh)	Absolute Time (Frames)(BCD)
2367(93Fh)	Zero

Table 5.12: Subcode-Q Field (Mode-2)

OFFSET	7	6	5	4	3	2	1	0
2352(930h)	P	Q	R	S	T	U	V	W
2353(931h)	P	Q						
2354(932h)	P	Q						
⋮								
2445(98Dh)	P	Q						
2446(98Eh)	P	Q						
2447(98Fh)	P	Q	R	S	T	U	V	W

Table 5.13: Subcode R-W Data Format

Density Code 82/84h, Block Length = 2352d(930h)

CD-DA DIGITAL AUDIO DATA STREAM	930
000 (Address) ← LogicalBlock →	

Where;

CD-DA DIGITAL AUDIO DATA STREAM: This field is composed of one subcode frame ($\frac{1}{75}$ sec) with following table.

OFFSET	DESCRIPTION
0(000h)	Left Channel Data (Lower8bits)
1(001h)	Left Channel Data (Upper8bits)
2(002h)	RightChannel Data (Lower8bits)
3(003h)	RightChannel Data (Upper8bits)
4(004h)	_____
⋮	_____
2347(92Bh)	_____
2348(92Ch)	Left Channel Data (Lower8bits)
2349(92Dh)	Left Channel Data (Upper8bits)
2350(92Eh)	RightChannel Data (Lower8bits)
2351(92Fh)	RightChannel Data (Upper8bits)

Density Code 82/84h, Block Length = 2368d(940h)

CD-DA DIGITAL AUDIO DATA STREAM	SUBCODE-Q DATA	940
000 (Address)	930	
← LogicalBlock →		

Density Code 82/84h, Block Length = 2448d(990h)

CD-DA DIGITAL AUDIO DATA STREAM	SUBCODE P-W DATA	990
000 (Address)	930	
← LogicalBlock →		

Other Density Code

SYNC	HEADER	USER DATA	ECC	930	MODE-1
000 00C	00C 004	010 800	810 120		

SYNC	HEADER	USER DATA	930	MODE-2
000 00C	00C 004	010 920		

SYNC	HEADER	SUB-HEADER	USER DATA	ECC	930	FORM-1
000 00C	00C 004	010 008	018 800	818 118		

SYNC	HEADER	SUB-HEADER	USER DATA	930	FORM-2
000 00C	00C 004	010 008	018 918		

Block Length Combination is follow;

SIZE	MODE-1	MODE-2	FORM-1	FORM-2	CDDA	DVD
2048(800h)	User	—	User	—	—	Data
2056(808h)	—	—	SubH+User	—	—	—
2336(920h)	User+ECC	User	SubH+User+ECC	SubH+User	—	—
2340(924h)	Head+User+ECC	Head+User	Head+SubH+User+ECC	Head+SubH+User	—	—
2352(930h)	All	All	All	All	Data	—
2448(990h)	All+SubQ	All+SubQ	All+SubQ	All+SubQr	Data+SubQ	—
2368(940h)	All+RTW	All+RTW	All+RTW	All+RTW	Data+RTW	—
16(10h)	SubQ	SubQ	SubQ	SubQ	SubQ	—
96(60h)	RTW	RTW	RTW	RTW	RTW	—

5.10.3 Page Descriptor(s)

Byte 00 bit 7 : Parameter Save (not support: should be set to **zero**)

Byte 00 : Page Code

This field specifies the format and parameters for that Page defined in SFF-8090. The DVD-ROM drive supports following Pages.

- Page 01 ... Read/Write Error recovery parameters
- Page 02 ... Disconnect/Reconnect Control parameters
- Page 0D ... Drive parameters
- Page 0E ... CD Audio Control parameter
- Page 1A ... Power Condition Mode parameters
- Page 1D ... C/DVD Time-out & Protect parameters
- Page 20 ... Obsolete

Byte 01 : Page Length

This field specifies the length in bytes of the following page descriptors. The Page Length of each Page is as follows, and if other length is specified, the DVD-ROM drive returns CHECK CONDITION status.

Page 01 ... 0Ah (06h just accept for backward compatible)
Page 02 ... 0Eh (Note that this field was 0Ah in CCS definition)
Page 0D ... 06h
Page 0E ... 0Eh
Page 1A ... 0Ah
Page 1D ... 08h

Byte 02 to NN : Page Parameter

Indicates the parameters for each Pages describe on Section 5.13 MODE SENSE command.

5.11 RESERVE command

	7	6	5	4	3	2	1	0	NOTE
00	Operation Code								16h
01	LUN		3rdPty	Third Party Device ID			Extent		
02	Reservation Identification								00h
03	(MSB)	Extent List Length						(LSB)	00h
04									00h
05	Reserved					Flag		Link	
06									—
07									—
08	PAD								—
09									—
10									—
11									—

COMMAND FUNCTION Reserve the DVD-ROM drive for exclusive use of an initiator.

The DVD-ROM drive supports following three reservation modes.

- Logical Unit Reservation
- Third Party Reservation
- Superseding Reservation

< Command Type > : Mandatory (SCSI-2)

<3rdPty > : Third Party bit of **one** indicates Third Party Reservation request.

< Third Party Device ID > : This field is used to identify the SCSI ID for Third Party Reservation request.

<Extent > : Drive does not support this function, should be set to **zero**.

DESCRIPTION This command is used to reserve the DVD-ROM drive for exclusive use of an initiator. Under reservation status, if any other initiator sends any command other than an INQUIRY, REQUEST SENSE, PREVENT/ALLOW MEDIUM REMOVAL, RELEASE command (ignored), the DVD-ROM drive returns RESERVATION CONFLICT status and does not execute the requested command.

Note that the initiator shall identify its SCSI ID during SELECTION phase. If the initiator output only drive's SCSI ID during SELECTION phase, the DVD-ROM drive rejects the RESERVE command with CHECK CONDITION status.

The reservation shall remain in effect until following events occur.

1. Release by RELEASE command from the initiator that made the reservation.
2. BUS DEVICE RESET message is issued from any initiator.
3. RESET condition is created by any SCSI device.
4. Reservation is superseded by another RESERVE command from the initiator that made the reservation.

The DVD-ROM drive supports above mentioned three kinds of reservation and does not support Extent Reservation request.

1. Logical Unit Reservation

If the Extent and 3rdPty bit is set to **zero**, this request is to reserve the DVD-ROM drive for exclusive use of the initiator that issued this RESERVE command.

It is not an error to reserve the DVD-ROM drive that is currently reserved by that initiator.

2. Third Party Reservation

If the `3rdPty` bit is set to `one`, that DVD-ROM drive reserves itself for the SCSI device which is specified in the Third Party Device ID field.

That is, this reservation request provides a means for an initiator to reserve the DVD-ROM drive for another SCSI device and it intends to use for the execution of a `COPY` command.

3. Superseding Reservation

It is permitted for an initiator that holds current reservation to modify that reservation by issuing another `RESERVE` command.

This superseding `RESERVE` command releases the previous reservation and establishes new reservation status.

5.12 RELEASE command

	7	6	5	4	3	2	1	0	NOTE
00	Operation Code								17h
01	LUN		3rdPty	Third Party Device ID			Extent		
02	Reservation Identification								00h
03	Reserved								00h
04									00h
05							Flag	Link	
06									—
07									—
08	PAD								—
09									—
10									—
11									—

COMMAND FUNCTION

Release the current reservation status of the DVD-ROM drive.

The DVD-ROM drive supports following two release modes.

- Logical Unit Release
- Third Party Release

< Command Type > : Mandatory (SCSI-2)

<3rdPty > : Third Party bit of **one** indicates Third Party Reservation request.

< Third Party Device ID > : This field is used to identify the SCSI ID for Third Party Reservation request.

<Extent > : Drive does not support this function, should be set to **zero**.

DESCRIPTION

This command is used to release previously reserved the DVD-ROM drive.

It is not an error for an initiator to release the DVD-ROM drive that is not currently reserved. In this case, the DVD-ROM drive returns GOOD status without changing any other reservation.

Note that the initiator shall identify its SCSI ID during SELECTION phase. If the initiator has output only drive's SCSI ID during SELECTION phase, the DVD-ROM drive reports CHECK CONDITION status with sense key set to ILLEGAL REQUEST.

1. Logical Unit Release

If the Extent and 3rdPty bit is set to **zero**, this request is to release non-third-party reservation.

2. Third Party Release

If the 3rdPty bit is set to **one**, that DVD-ROM drive release the reservation if the reservation was made using a Third Party Reservation by the initiator that is requesting the release for the same SCSI device as specified in the Third Party Device ID field (Byte 01).

That is, this release request provides a means for an initiator to release the DVD-ROM drive that was reserved for another SCSI device and it intends to use for the execution of a COPY command.

5.13 MODE SENSE(6) command

	7	6	5	4	3	2	1	0	NOTE
00	Operation Code								1Ah
01	LUN		Reserved	DBD	Reserved				(00h)/08h
02	PC		Page Code						
03	Reserved								00h
04	Allocation Length								
05	Reserved					Flag	Link		
06									—
07									—
08	PAD								—
09									—
10									—
11									—

COMMAND FUNCTION

Reports the current, changeable and default value of page parameters. This command is a complementary command to the MODE SELECT command.

< Command Type > : Mandatory (Core)

< DBD > : Disable block Descriptor

< PC > : Page Control field defines the type of parameters to be returned

< Page Code > : Specifies which page or pages to return

< Allocation Length > : Maximum number of bytes that the Host Computer has allocated for returned MODE SENSE data

DESCRIPTION

This command provides a means for the DVD-ROM drive to report current (specified with a MODE SELECT command), changeable and default value of page parameters.

The DBD bit specifies that the Block descriptors are not returned when set to **one**. This bit shall always be set to **one**. But this bit may be set to **zero** in a legacy environment (ex. SFF-8020,SCSI). Thus the DVD-ROM drive does not check this bit.

As the DVD-ROM drive does not support the saving page function, it returns a CHECK CONDITION status with the additional sense code set to SAVING PARAMETERS NOT SUPPORTED for the request of PC field set to 11b.

5.13.1 MODE PAGE setting

The page code specifies which page or pages to return defined as follows.

Page Code = 01h : Read/Write Error recovery parameters

Page Code = 02h : Disconnect/Reconnect Control parameters

Page Code = 0Dh : Drive parameters

Page Code = 0Eh : CD Audio Control parameters

Page Code = 1Ah : Power Condition parameters

Page Code = 1Dh : C/DVD Time-out & Protect parameters

Page Code = 20h : Obsolete

Page Code = 2Ah : C/DVD Capabilities & Mechanical Status parameters

Page Code = 3Fh : All Pages transfer

If the Host Computer issues a MODE SENSE command with specifying not-supported page, the DVD-ROM drive returns a CHECK CONDITION status.

Page Code of 3Fh indicates that all pages are returned in ascending order.

The returned parameters are as follows.

BIT7	BIT6	TRANSFER PARAMETER TYPE
0	0	Current Value
0	1	Changeable Value
1	0	Default Value
1	1	Saved Value <<INVALID>>

Table 5.14: PC Field

Current Values(PC = 00b)

The current value are reported to the Host Computer.

The current value means either the value that was set by the last MODE SELECT command or the default value when a MODE SELECT command has not been issued.

Changeable Value (PC = 01b)

The changeable value (Changeable mask) are reported to the Host Computer.

All corresponding parameter bits that are changeable through a MODE SELECT command are set to **one** and all corresponding parameter bits that is not allowed to be changed are set to **zero**.

If the Host Computer issuer a MODE SELECT command with non-changeable bit set to **one**, a CHECK CONDITION status is reported.

Default Value (PC = 10b)

The default value(power on default) are reported to the Host Computer.

Saved Value (PC = 11b)

DVD-ROM drive does not support page-saving function. Thus MODE SENSE command with PC = 11b will be terminate with ILLEGAL REQUEST status.

The allocation length field specifies the maximum number of bytes that the initiator has allocated for returned MODE SENSE data to be sent during DATA IN phase.

The DVD-ROM drive terminates the DATA IN phase when allocation length bytes have been transferred or when all available MODE SENSE data have been transferred to the initiator, whichever is less.

If the allocation length field is equal or less than 12d with DBD bit set to **zero**, the maximum number of bytes to be transferred is 12 bytes.

If the allocation length field is equal or less than 4d with DBD bit set to **one**, the maximum number of bytes to be transferred is 4 bytes.

Otherwise, the maximum number of bytes to be transferred is depended upon the DBD bit and Page Code as follows.

5.13.2 MODE SENSE data

The allocation length field specific the maximum number of bytes that the Host Computer has allocated for the returned MODE SENSE data to be sent.

The DVD-ROM drive terminates the data transfer when the allocation length bytes have been transferred or when all available MODE SENSE data have been transferred to the Host Computer, whichever is less.

PAGE CODE	DBD	MAXIMUM LENGTH	PAGE CODE	DBD	MAXIMUM LENGTH
01h	0b	24 bytes	01h	1b	16 bytes
02h	0b	28 bytes	02h	1b	20 bytes
0Dh	0b	20 bytes	0Dh	1b	12 bytes
0Eh	0b	28 bytes	0Eh	1b	20 bytes
1Ah	0b	24 bytes	1Ah	1b	16 bytes
1Dh	0b	22 bytes	1Dh	1b	14 bytes
2Ah	0b	28 bytes	2Ah	1b	30 bytes
3Fh	0b	115 bytes	3Fh	1b	107 bytes

Table 5.15: Maximum Transfer Length

	7	6	5	4	3	2	1	0	NOTE
00	Mode Data Length								
01	Medium Type								
02	Drive Specific Parameter								00h
03	Block Description Length								00/08h
	<i>Block Descriptor(s)</i>								
00	Density Code								
01	(MSB)								00h
02	Number of Blocks								00h
03							(LSB)	00h	
04	Reserved								00h
05	(MSB)								00h
06	Block Length								
07							(LSB)		
	<i>Page Descriptor(s)</i>								
00	PS(0)	Reserved	Page Code						
01	Page Length								
02									
⋮	Page Parameter (refer to each page description)								⋮
NN									

Table 5.16: Mode Sense(6) Parameter List

The MODE SENSE data (Table 5.16) contains eight bytes mode parameter header followed by zero or more pages.

Mode Data Length field specifies the length in bytes of the following data that is available to be transferred.

Medium Type field shows information of current Tray(Drawer) status and/or installed medium's type shown in Table 5.17. However note that 120mm CD disc may be misrecognized as a 80mm CD disc, since the DVD-ROM drive judges this type by TOC information only. That is, if the 120mm CD disc has small capacity, the DVD-ROM drive may regard it as a 80mm CD disc.

5.13.3 Page 01 (Read/Write Error Recovery parameters)

Error Recovery parameters page specifies the error recovery parameters that the DVD-ROM drive uses during the read operation due to READ commands execution.

CODE	MEDIUM TYPE DESCRIPTION	
00h	Medium type unknown	Tray closed
01h	120 mm CD-ROM data only	Tray closed
02h	120 mm CD-DA audio	Tray closed
03h	120 mm CD-ROM data and audio combined	Tray closed
04h	120 mm CD-ROM Hybrid disc (Photo CD)	Tray closed
05h	80 mm CD-ROM data only	Tray closed
06h	80 mm CD-DA audio	Tray closed
07h	80 mm CD-ROM data and audio combined	Tray closed
08h	80 mm CD-ROM Hybrid disc (Photo CD)	Tray closed
09h - 1Fh	<i>Reserved</i>	
20h	Medium type (CD-RW) size unknown	Tray closed
21h	120 mm CD-ROM(CD-RW) data only	Tray closed
22h	120 mm CD-DA(CD-RW) audio	Tray closed
23h	120 mm CD-ROM(CD-RW) data and audio combined	Tray closed
24h	120 mm CD-ROM(CD-RW) Hybrid disc (Photo CD)	Tray closed
25h	80 mm CD-ROM(CD-RW) data only	Tray closed
26h	80 mm CD-DA(CD-RW) audio	Tray closed
27h	80 mm CD-ROM(CD-RW) data and audio combined	Tray closed
28h	80 mm CD-ROM(CD-RW) Hybrid disc (Photo CD)	Tray closed
29h - 40h	<i>Reserved</i>	
41h	DVD media	Tray closed
42h - 6Fh	<i>Reserved</i>	
70h	No disc present	Tray closed
71h	Unknown	Tray open
72h	Medium format error	Tray closed
73h - 7Fh	<i>Reserved</i>	
80h - FFh	<i>Vendor Unique(Not used)</i>	

Table 5.17: Medium Type Code

	7	6	5	4	3	2	1	0	NOTE
00	PS	Reserved	Page Code						01h
01	Page Length								(06/)0Ah
<i>Error Recovery Page parameters</i>									
02	AWRE	ARRE	TB	RC	Reserved	PER	DTE	DCR	
03	Read Retry Count								
04	Reserved (<i>Correction Span in SCSI SBC</i>)								00h
05	Reserved (<i>Head Offset count in SCSI SBC</i>)								00h
06	Reserved (<i>Data Strobe Offset Count in SCSI SBC</i>)								00h
07	Reserved								00h
08	Reserved for Write Retry Count								00h
09	Reserved								00h
10	Reserved for Recovery Time Limit								00h
11									00h

Table 5.18: Read/Write Error Recovery Parameters Page

Table 5.19 shows the available bit setting and its interpretation for CD-ROM media on DVD-ROM drive . If another combination is specified, CHECK CONDITION status is reported.

AWRE ⁶ bit of **one** indicates that a logical unit is enable automatic reallocation to be performed during write operations.

*This function is no affect for ROM device then Toshiba DVD-ROM drive not-support this bit, should be set to **zero***

ARRE ⁷ bit of **one** indicates that a logical unit is enable automatic reallocation of defective data blocks during read operation. When ARRE is enabled other error recovery modes is not used. The Disable Correction and Read Continuous is not enabled while ARRE is enabled.

*This function is no affect for ROM device then Toshiba DVD-ROM drive not-support this bit, should be set to **zero***

TB ⁸ bit of **one** indicates that a data block that is not recovered within the recovery limits specified, is transferred to the Host Computer before CHECK CONDITION status is returned. A TB bit of **zero** indicates that such a data block is not transferred to the Host Computer. The TB bit does not affect the action taken for recovered data.

RC ⁹ bit of **one** indicates that the DVD-ROM drive transfer the entire requested length of data without adding delays to perform error recovery procedures. This implies that the DVD-ROM drive may send data that is erroneous or fabricated in order to maintain a continuous flow of data. A RC bit of **zero** indicates that error recovery operations that cause delays are acceptable during the data transfer.

PER ¹⁰ bit of **one** indicates that the DVD-ROM drive report recovered errors. A PER bit of **zero** indicates that the DVD-ROM drive does not report recovered errors. Error recovery procedures is performed within the limits established by the error recovery parameters.

This capability is very different for DVD media. To be able to recover the data from DVD media, error correction must be used. Thus it is not reasonable to report when ECC is used to recover the data. This bit for DVD media is only used to report when auto reallocation of a logical block has been performed.

For CD media this capability is used to report when the Layered Error correction has been used to recover the data. Again as the CIRC is mandatory for recovery of data it is not cause recovered errors to be reported.

DTE ¹¹ bit of **one** indicates that the DVD-ROM drive terminate the data transfer to the Host upon detection of a recovered error. A DTE bit of **zero** indicates that the DVD-ROM drive is not terminate the data transfer upon detection of a recovered error.

DCR ¹² bit of **one** indicates that error correction codes are not used for data error recovery. A DCR bit of **zero** allows the use of error correction codes for data error recovery.

⁶AWRE : Automatic Write Reallocation Enabled

⁷ARRE : Automatic Read Reallocation Enabled

⁸TB : Transfer Block

⁹RC : Read Continuous

¹⁰PER : Post Error Report

¹¹DTE : Disable Transfer on Error

¹²DCR : Disable Correction Recovery

Byte 02	DESCRIPTION
00h	Uses both ECC and retry. If an uncorrectable error occurs, data transfer is terminated with CHECK CONDITION status. The erroneous block is not transferred. Recovered error is not reported.
01h	Uses only retry. If an CIRC uncorrectable error occurs, data transfer is terminated with CHECK CONDITION status. The erroneous block is not transferred. Recovered error is not reported.
04h	Uses both ECC and retry. If an uncorrectable error occurs, data transfer is terminated with CHECK CONDITION status. The erroneous block is not transferred and the information byte in sense data gives the address where the error was detected. If a recovered error occurs, data transfer is not terminated, however CHECK CONDITION status is reported at command completion. The sense key is RECOVERED ERROR and the information byte gives the address of the last recovered block.
05h	Uses only retry. If an CIRC uncorrectable error occurs, data transfer is terminated with CHECK CONDITION status. The erroneous block is not transferred and the information byte in sense data gives the address where the error was detected. If a recovered error occurs, data transfer is not terminated, however CHECK CONDITION status is reported at command completion. The sense key is RECOVERED ERROR and the information byte gives the address of the last recovered (retried) block.
06h	Uses both ECC and retry. If an uncorrectable error occurs, data transfer is terminated with CHECK CONDITION status. The erroneous block is not transferred and the information byte in sense data gives the address where the error was detected. If a recovered error occurs, data transfer is terminated with CHECK CONDITION status. The recovered block is not transferred and the sense key is RECOVERED ERROR and the information byte gives the address of the recovered block.
07h	Uses only retry. If an CIRC uncorrectable error occurs, data transfer is terminated with CHECK CONDITION status. The erroneous block is not transferred and the information byte in sense data gives the address where the error was detected. If a recovered error occurs, data transfer is terminated with CHECK CONDITION status. The recovered block is not transferred and the sense key is RECOVERED ERROR and the information byte gives the address of the recovered (retried) block.
10h	Uses only ECC to maintain data transfer rate. If uncorrectable error occurs, data transfer is not terminated, however CHECK CONDITION status is reported at command completion. The information byte in sense data gives the address of first uncorrectable block. Note that erroneous data may be transferred in this mode. Recovered error is not reported.
11h	Uses no error recovery operation to maintain data transfer rate. If uncorrectable error occurs, data transfer is not terminated, however CHECK CONDITION status is reported at command completion. The information byte in sense data gives the address of first uncorrectable block. Note that erroneous data may be transferred in this mode. Recovered error does not occur and is not reported.
14h	Uses only ECC to maintain data transfer rate. If uncorrectable error occurs, data transfer is not terminated, however CHECK CONDITION status is reported at command completion. The information byte in sense data gives the address of first uncorrectable block. Note that erroneous data may be transferred in this mode. If a recovered error occurs, data transfer is not terminated, however CHECK CONDITION status is reported at command completion. The sense key is RECOVERED ERROR and the information byte gives the address of the last recovered block.
15h	Same as 14h.
20h	Uses both ECC and retry. If uncorrectable error occurs, data transfer is terminated with CHECK CONDITION status. The erroneous block is transferred and the information byte in sense data gives the address where the error was detected. Recovered error is not reported.
21h	Uses only retry. If an CIRC uncorrectable error occurs, data transfer is terminated with CHECK CONDITION status. The erroneous block is transferred and the information byte in sense data gives the address where the error was detected. Recovered error is not reported.
24h	Uses both ECC and retry. If uncorrectable error occurs, data transfer is terminated with CHECK CONDITION status. The erroneous block is transferred and the information byte in sense data gives the address where the error was detected. If a recovered error occurs, data transfer is not terminated, however CHECK CONDITION status is reported at command completion. The sense key is RECOVERED ERROR and the information byte gives the address of the last recovered block.
25h	Uses only retry. If an CIRC uncorrectable error occurs, data transfer is terminated with CHECK CONDITION status. The erroneous block is transferred and the information byte in sense data gives the address where the error was detected. If a recovered error occurs, data transfer is not terminated, however CHECK CONDITION status is reported at command completion. The sense key is RECOVERED ERROR and the information byte gives the address of the last recovered (retried) block.
26h	Uses both ECC and retry. If an uncorrectable error occurs, data transfer is terminated with CHECK CONDITION status. The erroneous block is transferred and the information byte in sense data gives the address where the error was detected. If a recovered error occurs, data transfer is terminated with CHECK CONDITION status. The recovered block is transferred and the sense key is RECOVERED ERROR and the information byte gives the address of the recovered block.
27h	Uses only retry. If an CIRC uncorrectable error occurs, data transfer is terminated with CHECK CONDITION status. The erroneous block is transferred and the information byte in sense data gives the address where the error was detected. If a recovered error occurs, data transfer is terminated with CHECK CONDITION status. The recovered block is transferred and the sense key is RECOVERED ERROR and the information byte gives the address of the recovered (retried) block.
30h	Same as 10h.
31h	Same as 11h.
34h	Same as 14h.
35h	Same as 15h.

Table 5.19: Error Recovery Parameter

Retry Count field specifies the maximum number of times that the DVD-ROM drive should attempt its retry operation. Retry operation up to 254d (FEh) can be specified with this field. Retry Count of **zero** indicates that the retry operation is not allowed, and **FFh** (255d) indicates that retry operation is allowed limitlessly. The default value of the drive is ten (10) times.

5.13.4 Page 02 (Disconnect/Reconnect Control parameters)

Disconnect/Reconnect Control parameters page specifies the performance (restriction) of the SCSI bus.

	7	6	5	4	3	2	1	0	NOTE
00	PS	Reserved	Page Code						02h
01	Page Length								0Eh
02	Buffer Full Ratio								
03	Buffer Empty Ratio								00h
04	(MSB)	Bus Inactivity Limit						(LSB)	00h
05									00h
06	(MSB)	Disconnect Timer Limit						(LSB)	00h
07									00h
08	(MSB)	Connect Timer Limit						(LSB)	00h
09									00h
10	(MSB)	Maximum Burst Size						(LSB)	00h
11									00h
12								DTDC	00h
13	Reserved								00h
14									00h
15									00h

Table 5.20: Disconnect/Reconnect Control Parameters Page

Buffer Full Ratio field indicates how full the buffer shall be prior to reconnect during the **READ** family command execution and it is the numerator of a fractional multiplier that has 256 as its denominator.

Buffer Full Ratio of 00h indicates that the DVD-ROM drive shall not disconnect once the data transfer of the command has started. (Toshiba unique definition) The default of the Buffer Full Ratio is 20h.

Following show the **READ** command implementation algorithm when the disconnecting is allowed by the initiator and DTDC field is set to 00b.

1. The initiator sends **READ** command with DiscPriv bit in **IDENTIFY** message set to —bf one.
2. The DVD-ROM drive sends **DISCONNECT** message and goes to **BUS FREE** phase.
3. The DVD-ROM drive seeks to the requested block and starts to write data into the buffer.
4. The DVD-ROM drive waits for the stored data amount to exceed either the Buffer Full Ratio or the remaining transfer length, whichever is less.
5. The DVD-ROM drive executes **ARBITRATION** phase and **RESELECTION** phase to reselect the initiator.
6. The DVD-ROM drive sends **IDENTIFY** message to the initiator. The initiator should restore the active pointers from the saved pointer.
7. The DVD-ROM drive goes to **DATA IN** phase and transfers data stored in buffer. The data transfer will continue until either of following events occurs.

- (a) The remaining transfer length is **zero**.
- (b) The buffer is empty.

Note that empty here means that the data in buffer is less than one physical block of the DVD-ROM drive .

- 8. If the remaining transfer length is **zero** (condition 7a), the DVD-ROM drive sends status bytes and message to the initiator and terminates the **READ** command.
- 9. If the remaining transfer length is not **zero** (condition 7b and 7b), the DVD-ROM drive sends **SAVE DATA POINTER** message and **DISCONNECT** message to the initiator and goes to **BUS FREE** phase.

The DVD-ROM drive repeats step 4 to 9 until all transfer length is exhausted.

5.13.5 Page 0D (Drive parameters)

Drive parameters page specifies the DVD-ROM drive unique parameters.

	7	6	5	4	3	2	1	0	NOTE
00	PS	Reserved	Page Code						0Dh
01	Page Length								06h
02	Reserved								00h
03	Reserved				Inactivity Timer Multiplier				
04	Number of MSF - S Units per MSF - M Unit								00h
05	(60)								3Ch
06	Number of MSF - F Units per MSF - S Unit								00h
07	(75)								4Bh

Table 5.21: Drive Parameter Page

Inactivity Timer Multiplier field indicates the length of time that the DVD-ROM drive remain in hold-track mode after completion of seek, read, audio playback and/or initialization operation before shifting **STOP** status (turning off the spindle motor and laser beam). During hold-track mode, the DVD-ROM drive attempts to keep the optical pickup head around the position where the previous operation has terminated. Table 5.21 shows the Inactivity Timer Multiplier. Default of the Half-Hight drive is 0Eh (16 *minutes*).

5.13.6 Page 0E (CD Audio Control parameters)

The CD Audio Control parameters page specifies the Audio playback mode and output control mode during Audio-CD playback operation. As Toshiba DVD-ROM drive does not support ADPCM audio function, this page does not have byte 16 to 143 field.

Immed¹³ bit set to **one** indicates that the DVD-ROM drive send a status as soon as the audio playback operation has been initiated.

SOTC¹⁴ bit set to **zero** indicates that the DVD-ROM drive only terminates the audio playback operation when the requested transfer length is satisfied.

Audio silence (Index 0) is also played and multiple tracks may be played as necessary.

SOTC bit set to **one** indicates that the DVD-ROM drive terminates the audio playback operation either when the beginning of next track (Index 0 or 1) is encountered or when the requested transfer length is satisfied.

¹³Immed : Immediate to clear host bus, command execute to background task

¹⁴STOC : Stop On Track Crossing

INACTIVITY TIMER MULTIPLIER	MINIMUM TIME IN HOLD-TRACK MODE
00h	62 <i>milliseconds</i>
01h	125 <i>milliseconds</i>
02h	250 <i>milliseconds</i>
03h	500 <i>milliseconds</i>
04h	1 <i>second</i>
05h	2 <i>seconds</i>
06h	4 <i>seconds</i>
07h	8 <i>seconds</i>
08h	16 <i>seconds</i>
09h	32 <i>seconds</i>
0Ah	1 <i>minute</i>
0Bh	2 <i>minutes</i>
0Ch	4 <i>minutes</i>
0Dh	8 <i>minutes</i>
0Eh	16 minutes
0Fh	32 <i>minutes</i>

Table 5.22: Inactivity Timer Multiplier

	7	6	5	4	3	2	1	0	NOTE	
00	PS	Reserved	Page Code						0Eh	
01	Page Length								0Eh	
02							Immed	SOTC	04/06h	
03									00h	
04	Reserved								00h	
05									00h	
06	(MSB)	Logical Block per Second of Audio Playback							00h	
07	(75)								(LSB)	4Bh(/00h)
08	Reserved				Output Port 0 Channel Control					
09	Output Port 0 Volume									
10	Reserved				Output Port 1 Channel Control					
11	Output Port 1 Volume									
12	Reserved				Output Port 2 Channel Control				00h	
13	Output Port 2 Volume								00h	
14	Reserved				Output Port 3 Channel Control				00h	
15	Output Port 3 Volume								00h	

Table 5.23: CD Audio Control Parameter

Default setting of the DVD-ROM drive is Immed bit set to **one** (*not changeable*) and SOTC bit set to **zero**.

Output Port χ Channel Control field specifies the audio channels from the disc to which this output port should be connected.

The DVD-ROM drive support 2 channel control (Channel 0 and 1) and following table shows the available combination and its function for each channel.

Namely 16 patterns are available and if any other combination is specified, **CHECK CONDITION** status is reported.

The default of the DVD-ROM drive is so-called stereo mode (Byte 8 set to 01h and Byte 9 set to 02h).

CHANNEL SELECTION	FUNCTION
0000b(0h)	Output muted
0001b(1h)	Connect channel 0 to this output port
0010b(2h)	Connect channel 1 to this output port
0011b(3h)	Connect channel 0 and 1 to this output port
0100b(4h)	Connect channel 2 to this output port <i>Reserved</i>
1000b(5h)	Connect channel 3 to this output port <i>Reserved</i>

Table 5.24: Output Port channel Selection

Output Port \times Volume field specifies the relative volume level for this audio port.

A value of **zero** means output port muted and FFh means the maximum volume level.

The default value of the DVD-ROM drive is 100% (FFh).

It is possible to control the channel 0 and channel 1 independent, however note that channel 2 and 3 should be **zero**.

The actual attenuation level for any given binary attenuation level is given by the following equation : $20 \times \log \frac{\text{BinaryLevel}+1}{256}$

BINARY LEVEL	ATTENUATION
FFh	0 <i>db</i> (on)
FEh	-0.56 <i>db</i>
EFh	-1.16 <i>db</i>
CEh	-2.50 <i>db</i>
80h	-6.00 <i>db</i>
40h	-12.0 <i>db</i>
20h	-18.0 <i>db</i>
1Fh	-24.0 <i>db</i>
0Fh	-24.6 <i>db</i>
0Eh	-25.2 <i>db</i>
0Dh	-26.6 <i>db</i>
0Bh	-30.0 <i>db</i>
07h	-36.0 <i>db</i>
03h	-42.1 <i>db</i>
01h	-48.0 <i>db</i>
00h	$-\infty$ <i>db</i> (off)

Table 5.25: Attenuation

5.13.7 Page 1A (Power Condition parameters)

The power condition page provides the application client the means to control the length of time the drive will delay before changing its power requirements. There are notification events to the host that the drive has entered into one of the power conditions.

On the receipt of a command the drive will adjust itself to the power condition which allows the command to execute. The timer which maps to this power condition and any lower power condition timers will be reset on receipt of the command. On completion of the command the timer associated with this power condition will be restarted.

Idle bit of **one** indicates the drive will use the Idle Timer to determine the length of inactivity time to wait before entering the Idle condition.

	7	6	5	4	3	2	1	0	NOTE	
00	PS	Reserved	Page Code						1Ah	
01	Page Length								0Ah	
02	Reserved								00h	
03							Idle	Standby		
04	(MSB)	Idle Timer								00h
05	(100millisecond, 00000001)								00h	
06										
07							(LSB)			
08	(MSB)	Standby Timer								00h
09	(100millisecond, 00000001)								00h	
10										
11							(LSB)			

Table 5.26: Power Condition parameters

Idle Timer field indicates the inactivity time in 100 *millisecond* increment that the drive will wait before entering the Idle condition.

Value of Idle Timer affect range is 00000001 - 00003FFFh.

If the Idle bit is zero, or a value of zero in the Idle Timer indicates the drive will disable the Idle Timer.

Standby bit of **one** indicates the drive will use the Standby Timer to determine the length of inactivity time to wait before entering the Standby condition.

Standby Timer field indicates the inactivity time in 100 *millisecond* increments that the drive will wait before entering the Standby condition.

Value of Standby Timer affect range is 00000001 - 00003FFFh.

If the Standby bit is zero or a value of zero in the Standby Timer indicates the logical unit will disable the Standby Timer.

Timers

The Idle and Standby timers provide a method for the logical unit to enter lower power states after a host programmable period of inactivity, without direct host command.

A timer is de-activated (no longer used by the Logical Unit, regardless of Enable/Disable setting provided from the host) when the logical unit is in the associated power state or a lower power state.

A timer is both reactivated (the logical unit use the timer if enabled) and reloaded when a logical unit transitions to power state higher than the associated timer.

Timers are reloaded using the current timer value from this page. Timers are disabled/enabled as specified in this page.

Timers are set to default conditions upon receiving a power-on, or hard reset.

5.13.8 Page 1D (C/DVD Time-out & Protect parameters)

The C/DVD Time-out & Protect parameters page specifies parameters that affect C/DVD operation.

	7	6	5	4	3	2	1	0	NOTE
00	PS	Reserved	Page Code						1Dh
01	Page Length								08h
02	Reserved								00h
03	Reserved								00h
04					TMOE	DISP	SWPP		00/04h
05	Reserved								00h
06	(MSB)	Group 1 Minimum Time-out(Seconds)							
07							(LSB)		
08	(MSB)	Group 2 Minimum Time-out(Seconds)							
09							(LSB)		00h

Table 5.27: C/DVD Time-out & Protect Page Format

TMOE¹⁵ bit when set to **one** enables the Time-out capability. A bit of **zero** disables the Time-out reporting capability.

DISP¹⁶ bit is not support by Toshiba DVD-ROM drive .

SWPP¹⁷ bit is not support by Toshiba DVD-ROM drive .

Time-outs models

Here is two time-out parameters in this C/DVD Time-out & Protect Page. This first parameter is the minimum time-out that an operating system must use for all commands in Group 1. The second parameter is the minimum time-out that an operating system must use for all commands in Group 2.

For commands in Group 1, the DVD-ROM drive start an internal timer when the command is received. If the command is unable to complete before the time specified in the Group 1 Time-out & Protect Page, bytes 06 and 07, the DVD-ROM drive terminate the command, at any time before the Group 1 Time-out expires, with a **Check Condition** (Sense Key 6h, UNIT ATTENTION, ASC 2Eh,ASCQ 00h INSUFFICIENT TIME FOR OPERATION) Additionally, the DVD-ROM drive set the Command Specific Information sense bytes (bytes 08-11 : refer to pp. 167) to the value in seconds that corresponds to the minimum time-out that the host should use when retrying this command. Upon receiving this **Check Condition**, the operating system retry the command with the requested time-out.

Note: The DVD-ROM drive return this check condition at any point after the command is receiving, it may even return prior to initiating command.

All commands in Group 2 are commands that may not be able to complete successfully if they are retried. Thus, the Host must ensure that it uses a time-out that is large enough to allow the command to complete under worst case scenarios. This time-out is specified by the Logical Unit in the Group 2 Time-out parameter of the C/DVD Time-out & Protect Page (bytes 08-09).

¹⁵TMOE : Time-out Enable

¹⁶DISP: When set to **one** will make the Device unavailable until power has been removed and then reapplied. The drive will report not ready for all media access after this bit has been set to **one**.

¹⁷SWPP: Provides a Software Write Protect until Powerdown. When this bit is set to **one** the drive will prevent writes to the media. When the bit is set to **one**, the drive will flush any data in the Cache to the media before preventing any future writes.

All of the supported commands for Toshiba DVD-ROM drive are Group 1 command, except REQUEST SENSE, INQUIRY, GET EVENT STATUS NOTIFICATION commands (these commands are immediate to complete execution).

5.13.9 Page 2Ah (Capability and Mechanical Status)

This page is read only and is not changed by MODE SELECT command.

	7	6	5	4	3	2	1	0	NOTE	
00	PS	Reserved	Page Code							2Ah
01	Page Length								18h	
02	Reserved		DVD-RAM Read	DVD-R Read	DVD-ROM Read	Method2	CD-RW Read	CD-R Read	1Fh	
03			DVD-RAM Write	DVD-R Write	Reserved	Test Write	CD-RW Write	CD-R Write	00h	
04			Multi Session	Mode 2 Form 2	Mode 2 Form 1	Digital Port(2)	Digital Port(1)	Composite	Audio Play	71h
05	Read Bar Code Capable	UPC	ISRC	C2 Pointers	R-W Deinterleaved & Corrected	R-W Support	CD-DA Accurate	CD-DA Support	77h	
06	Loading Mechanism Type			Reserved	Eject	Prevent Jumper	Lock State	Lock		
07	Reserved		R-W in Lead-in Readable	Side Change Capable	S/W Slot Selection (SSS)	Supports Disc Present (SDP)	Separate Channel Mute	Separate Volume Control	23h	
08	(MSB)	CD-ROM Maximum Speed Supported (in KBps)						(LSB)	1Bh	
09									90h	
10	(MSB)	CD-Audio Number of Volume Levels Supported						(LSB)	00h	
11									10h	
12	(MSB)	Buffer Size Supported by Logical Unit (in Kbytes)						(LSB)	00h	
13									80h	
14	(MSB)	CD-ROM Current Speed Selected (in KBps)						(LSB)		
15										
16	Reserved								00h	
17		Length			LSBF	RCK	BCK		18h	
18		Reserved							00h	
19									00h	
20		Reserved							00h	
21									00h	
22	(MSB)	Copy Management Revision Supported						(LSB)	00h	
23									01h	
24		Reserved							00h	
25									00h	

Table 5.28: Capability and Mechanical Status Parameter

Byte 02 Read Capability

Bit 5 : DVD-RAM Read

0b - Indicate the DVD-ROM drive does not support the read function of DVD-RAM media.

Bit 4 : DVD-R Read

1b - Indicate the DVD-ROM drive supported the read function of DVD-R media.

Bit 3 : DVD-ROM Read

1b - Indicate the DVD-ROM drive supported the read function of DVD-ROM media.

Bit 2 : Method2

1b - Indicate the drive supported the read function of CD-R¹⁸ media written using fixed packet tracks using Addressing Method2.

Bit 1 : CD-RW Read

1b - Indicate the drive supported the read function of CD-RW¹⁹ disc.

Bit 0 : CD-R Read

1b - Indicate the drive supported the read function of CD-R disc.

Byte 03 Write Capability

00h : drive does not support all of Write function.

Byte 04 Capability (Readable/Outputs)

Bit 6 : Multi-session

1b - Indicate the drive is capable of reading a multi session or a photo-CD format.

Bit 5 : Mode-2/Form-2

1b - Indicate the drive is capable of reading a XA Mode-2/Form-2 format.

Bit 4 : Mode-2/Form-1

1b - Indicate the drive is capable of reading a XA Mode-2/Form-1 format.

Bit 3 : Digital Port(2)

0b - Indicate the drive does not support the digital output (IEC958) on port2.

Bit 2 : Digital Port(1)

0b - Indicate the does not support the digital output (IEC958) on port1.

Bit 1 : Composite

0b - Indicate the drive is not capable of delivering a composite Audio and Video data stream.

Bit 0 : Audio Play

1b - Indicate the drive is capable of audio playback operation (support PLAY AUDIO command). Also indicate that the drive is capable of overlapping play and other commands such as READ SUB-CHANNEL.

Byte 05 Capability (Function)

Bit 7 : Read Bar Code

0b - Indicate the drive can not return CD media's Manufacturing Bar Code Data.

Bit 6 : UPC

1b - Indicate the drive can return Media Catalog Number (UPC).

Bit 5 : ISRC

1b - Indicate the drive can return International Standard Recording Code (ISRC).

Bit 4 : C2 Pointers are Supported

1b - Indicate the drive supported transferring the C2 error pointers and C2 block error flags for READ CD command.

¹⁸CD-R(Recordable): Refer to Orange Book Part II

¹⁹CD-RW(ReWritable) : Refer to Orange Book Part III

Bit 3 : R-W De-interleaved & Corrected

- 0b** - Indicate the drive returns the raw R-W data without applying the de-interleave and correction.
The Host Computer should de-interleave the data and apply ECC, if necessary.

Bit 2 : R-W Supported

- 1b** - Indicate the drive returns the raw subcode R-W data.

Bit 1 : CD-DA Stream is Accurate

- 1b** - Indicate the drive is capable of accurately restarting the CD-DA read operation.

Bit 0 : CD-DA Commands Supported

- 1b** - Indicate RED-BOOK audio (CD-DA audio) can be read using the **READ CD** command.

Byte 06 Mechanism Capable**Bit 7 - 5** : Loading Mechanism Type

- 001b** - Indicate Tray Type mechanism.

Bit 3 : Eject Command

- 1b** - Indicate the drive can eject the disc via a **START/STOP UNIT** command with **LoEj** bit set to **one**.

Bit 2 : Prevent Jumper : This indicates the status of the Prevent/Allow jumper.

- 0b** - No hardware Jumper is present and the drive is powered up to Allow state. Locking the drive with the **PREVENT/ALLOW** command does not prevent the insertion of media.

Bit 1 : Lock State

This indicates the current Prevent/Allow status.

- 0b** - the drive is currently in the Allow state.
1b - the drive is currently in the Prevent state.

For detail on Prevent/Allow implementation refer to section 5.17 **PREVENT/ALLOW MEDIUM REMOVAL** command.

Bit 0 : Lock

- 1b** - Indicates the **PREVENT/ALLOW MEDIUM REMOVAL** command is capable of actually locking the media into the drive.

Byte 07 Additional Capable**Bit 5** : R-W in Lead-in Readable

- 1b** - Indicates that the drive is capable of reading R-W subcode in the Lead-in.

Bit 4 : Side Change Capable

- 0b** - Indicates that the drive can not capable of selecting both sides of the discs. This capability can be reported for Logical Units that have changer functions.

Bit 3 : Software Slot Selection (SSS)

- 0b** - Indicate the drive does not controls the behavior of the **LOAD/UNLOAD** command when trying to load a Slot with no Disc present.

Bit 2 : Supports Disc Present (SDP)

- 0b** - Indicate the drive does not be contain an embedded changer, and that after a reset condition or if a cartridge is changed, it can report the exact contents of the slots. The response to the **MECHANISM STATUS** command will contain valid Disc is Present status information for all slots.

Bit 1 : Separate Channel Mute

1b - Indicate the audio muting capability for each channel can be controlled independently.

Bit 0 : Separate Volume Levels

1b - Indicate the audio volume level control capability for each channel can be controlled independently.

Byte 08 - 09 CD-ROM Maximum Capable Speed Supported

1B90h - Indicate to support CD-ROM 40x mode (7056 kilo-bytes/second)

Note that this rate means the sustained transfer rate²⁰ from best condition media.

Byte 10 - 11 Number of Volume Levels Supported

0010h - : Indicate 16 levels including *0db* and $-\infty$ (muting) are available.

Byte 12 - 13 Buffer Size Supported by Drive

0100h - Indicate the drive has a 256Kbytes buffer for data transfer to the Host Computer.

Byte 14 - 15 CD-ROM Current Speed Selected

This field is changed by SET CD-ROM SPEED command. Either of following value is returned.

1B90h - Current setting in CD-ROM 40x mode (7056 kilo-bytes/second)

134Bh - Current setting in CD-ROM 28x mode (4939 kilo-bytes/second)

0DC8h - Current setting in CD-ROM 20x mode (3528 kilo-bytes/second)

03EDh - Current setting in CD-ROM 5.7x mode (1005 kilo-bytes/second)

Note that this field shows the transfer rate of CD-ROM data.

Byte 17 Format of the Drives Digital Output

Bit 5 - 4: Length

01b - 16BCKs

Bit 3: Indicate LSBF

1b - LSB first

Bit 2: Indicate RCH

0b - HIGH on LRCK indicates left channel

Bit 1: BCKF

0b - Data valid on the falling edge of the BCK signal.

Byte 22 - 23 : Copy Management Revision Supported

0001h - Indicate the version of the DVD Copy Protection scheme that is supported.

5.13.10 Return Page Parameters

The page parameters to be returned depends upon the PC bits. PC bits =00b is 'Current' value, =01b is 'Changeable' value and =10b is 'Default' value. PC bits =11b is 'Saved' value, but the Toshiba DVD-ROM drive does not support this setting.

²⁰1x mean : 2352bytes×75frames/sec

Page 01 (Error Recovery parameters page)			
BYTE	CURRENT	CHANGEABLE	DEFAULT
00	01h		
01	0Ah		
02	??h	37h	00h
03	??h	FFh	0Ah
04 - 11	00h	00h	00h

Table 5.29: Mode Sense Data(Page 01)

Page 02 (Disconnect/Reconnect parameters page)			
BYTE	CURRENT	CHANGEABLE	DEFAULT
00	02h		
01	0Eh		
02	??h	00h	00h
03 - 11	00h	00h	00h

Table 5.30: Mode Sense Data(Page 02)

Page 0D (Drive Parameter)			
BYTE	CURRENT	CHANGEABLE	DEFAULT
00	0Dh		
01	06h		
02	00h	00h	00h
03	??h	0Fh	0Eh
04	00h	00h	00h
05	3Ch	00h	3Ch
06	00h	00h	00h
07	4Bh	00h	4Bh

Table 5.31: Mode Sense Data(Page 0D)

Page 0E (CD Audio Control Parameter)			
BYTE	CURRENT	CHANGEABLE	DEFAULT
00	0Eh		
01	0Eh		
02	04/06h	02h	04h
03 - 06	00h	00h	00h
07	4Bh	00h	4Bh
08	??h	03h	01h
09	??h	FFh	FFh
10	??h	03h	02h
11	??h	FFh	FFh
12 - 15	00h	00h	00h

Table 5.32: Mode Sense Data(Page 0E)

Page 1A (Power Condition)			
BYTE	CURRENT	CHANGEABLE	DEFAULT
00	1Ah		
01	0Ah		
02	00h	00h	00h
03	0?h	03h	03h
04 - 07	0000????h	00003FFFh	00000096h
08 - 11	0000????h	00003FFFh	000024EAh

Table 5.33: Mode Sense Data(Page 1A)

Page 1D (C/DVD Time-out & Protect)			
BYTE	CURRENT	CHANGEABLE	DEFAULT
00	1Dh		
01	08h		
02 - 03	00h	00h	00h
04	00/04h	04h	00h
05	00h	00h	00h
06 - 07	0???h	07FFh	0078h
08 - 09	0000h	0000h	0000h

Table 5.34: Mode Sense Data(Page 1D)

Page 2A (Capability and Mechanical State page)			
BYTE	CURRENT	CHANGEABLE	DEFAULT
00	2Ah		
01	18h		
02	1Fh	00h	1Fh
03	00h	00h	00h
04	71h	00h	71h
05	77h	00h	77h
06	2?h	00h	29h
07	23h	00h	23h
08 - 09	1B90	0000h	1B90h
10 - 11	0010h	0000h	0010h
12 - 13	0080h	0000h	0080h
14 - 15	????h	0000h	1B90h
16	00h	00h	00h
17	18h	00h	18h
18 - 21	00000000h	00000000h	00000000h
22 - 23	0001h	0000h	0001h
24 - 25	0000h	0000h	0000h

Table 5.35: Mode Sense Data(Page 2A)

5.14 START/STOP UNIT command

	7	6	5	4	3	2	1	0	NOTE	
00	Operation Code								1Bh	
01	LUN				Reserved				Immed	00/01h
02	Reserved								00h	
03	Reserved								00h	
04	Power Condition				LoEj		Start			
05	Reserved				Flag		Link			
06	Reserved								—	
07	Reserved								—	
08	PAD								—	
09	Reserved								—	
10	Reserved								—	
11	Reserved								—	

COMMAND FUNCTION

Request the drive to go to SETUP status, to go to STOP status, to open the Tray or to close the Tray.

< Command Type > : Mandatory (Removal / Power Management)

< Immed > : Immed²¹ bit of **one** indicates that the status is returned as soon as the operation is initiated.

Immed bit of **zero** indicates that the status is returned after the operation completes.

< LoEj > : LoEj²² bit of **one** requests to take an action regarding Tray/Drawer open/close operation.

< Start > : Start bit of **one** requests the DVD-ROM drive to go to SETUP status or to close the Tray.

Start bit of **zero** requests the DVD-ROM drive to go to STOP status or to open the Tray/Drawer.

< Power Condition > : Request power state defined in Table 5.37 to the DVD-ROM drive . If any bit is set in this field then Start and LoEj bit is ignored.

Byte 04			OPERATION TO BE PERFORMED
POWER CONDITION	LoEj	Start	
0000b	0	0	Stop the Disc
0000b	0	1	Start the Disc
0000b	1	0	Eject the Disc if possible (when not in prevented state)
0000b	1	1	Load the Disc (if Tray mechanism type drive)
≠0000b	x	x	Power Condition Change (Refer to Table 5.37)

Table 5.36: Start/Stop and Eject Operations

DESCRIPTION

This command requests the DVD-ROM drive to go to SETUP status, to go to STOP status, to open the Tray/Drawer or to close the Tray.

Immed bit of **one** indicates that the DVD-ROM drive is return a status as soon as the operation

²¹Immed: Immediate

²²LoEj : Load/Eject mechanism activity select bit

is initiated upon receipt of Command Packet and no status is returned after completion of the operation.

Immed bit of **zero** indicates that the status is returned after completion of the operation.

5.14.1 Load/Eject Operation

LoEj bit of **one** indicates that an action is taken regarding the Tray/Drawer open/close operation.

LoEj bit of **one** with Start bit set to **zero** requests to open the Tray/Drawer.

However note that the DVD-ROM drive returns a CHECK CONDITION status with MEDIA REMOVAL PREVENTED error code, if it is currently in the prevent mode.

LoEj bit of **one** with Start bit set to **one** requests to close the Tray (if Tray Model).

5.14.2 Spin Up/Down Operation

Start bit of **one** with LoEj bit of **zero** requests the DVD-ROM drive to go to SETUP status by executing following sequence.

- 1) Rotate the spindle motor
- 2) Turn on the laser beam, focusing servo and tracking servo
- 3) Enter hold-track (pause) mode

However note that it is not necessary to issue this command prior to each READ command even if the DVD-ROM drive is in STOP status, since the DVD-ROM drive implements same sequence described above automatically.

Start bit of **zero** with LoEj bit of **zero** requests the DVD-ROM drive to go to STOP status by executing following sequence.

- 1) Stop the spindle motor
- 2) Turn off the laser beam, focusing servo and tracking servo
- 3) Move the optical pickup head to the innermost position

5.14.3 Power Change Operation

CODE	DESCRIPTION
0000b	No change in power condition or in controlling power condition
0001b	<i>Reserved</i>
0010b	Place the drive into the Idle State, Standby Timer is reloaded
0011b	Place the drive into the Standby State
0100b	<i>Reserved</i>
0101b	Place the drive into the Sleep State.
<i>Others</i>	<i>Reserved</i>

Table 5.37: Power Conditions

In the Sleep condition the DVD-ROM drive can only respond to a reset condition.

5.15 RECEIVE DIAGNOSTICS RESULTS command

	7	6	5	4	3	2	1	0	NOTE
00	Operation Code								1Ch
01	LUN								00h
02	Reserved								00h
03	(MSB) Allocation Length								
04									(LSB)
05	Reserved						Flag	Link	
06									—
07									—
08	PAD								—
09									—
10									—
11									—

COMMAND FUNCTION

Request the drive to return analysis data to the host after completion of a **SEND DIAGNOSTIC** command.

< Command Type > : Vendor unique

< Allocation Length > : Maximum number of bytes that the host has allocated for the diagnostic data (if exist) to be received.

DESCRIPTION

This command requests the DVD-ROM drive to transfer the analysis data which shows the test results that was executed by the **SEND DIAGNOSTIC** command.

The allocation length field specifies the maximum number of bytes the host has allocated for the diagnostic data to be sent. The DVD-ROM drive terminate the Data transfer to host when the allocation length bytes have been transferred or when all available diagnostic data have been transferred to the host, whichever is less.

An allocation length of **zero** indicate that no data transferred.

5.16 SEND DIAGNOSTIC command

	7	6	5	4	3	2	1	0	NOTE
00	Operation Code								1Dh
01	LUN			PF	SIfTe		DvOfI	UntOf	
02	Reserved								00h
03	(MSB)	Parameter List Length						(LSB)	00h
04									06h(/00h)
05	Reserved					Flag	Link		
06									—
07									—
08	PAD								—
09									—
10									—
11									—

COMMAND FUNCTION

Request the drive to perform diagnostic test on itself.

And this command has a feature of Toshiba Vendor unique function : Imbalance Detection Mode.

< Command Type > : Vendor unique

< PF > : Page Format bit of **one** indicates that the parameters conform to SCSI-2 definition.

< SIfTe > : Self-Test bit of **one** directs the DVD-ROM drive to perform its default (pre-defined) diagnostics self test.

Self-Test bit of **zero** indicates that the operation is specified by the parameter list.

< DvOfI > : Device Off-Line bit, should be set to **zero**.

< UntOf > : Unit Off-Line bit, should be set to **zero**.

<Parameter List Length > : This field specifies the length in bytes of the Send Diagnostic parameter list that is transferred from the Host.

DESCRIPTION

This command requests the DVD-ROM drive to perform diagnostic test on itself specified by the SIfTe bit or parameter list. As the DVD-ROM drive does not support DvOfI²³ and UntOf²⁴ bit, it should be set to **zero**.

SIfTe²⁵ bit of **one** directs the DVD-ROM drive to perform its default diagnostics shall not be executed. If this self diagnostic test successfully passes, the command will be terminated with GOOD status, otherwise, the command will be terminated with CHECK CONDITION status if any error was detected.

SIfTe bit of **zero** indicates that the DVD-ROM drive should perform the diagnostic test specified in parameter list. There are several diagnostic tests prepared for manufacturing, however we can not disclose its contents because of Toshiba confidential and also we suppose it is not necessary for the customer to implement these tests, expect Imbalance Detection mode set function.

²³DvOfI : Device off-line

²⁴UntOf : Unit off-line

²⁵SIfTe : Self-Test

DATA OUT

	7	6	5	4	3	2	1	0	NOTE
00	Page Code								80h
01	Reserved								00h
02	(MSB)	Page Length						(LSB)	00h
03									02h
04	Function								00/01h
05	Reserved								00h

Table 5.38: Imbaranced Disc Detection Mode Select

Function

00h : Disable Imbalance Detection mode

01h : Enable Imbalance Detection mode

When execute **Send Diagnostic** command with Enable Imbalance Detection parameter, drive set to enable imbalance detection mode and execute imbalance test to followed media insertion, otherwise command with Disable Imbalance Detection parameter, drive set to disable imbalance detection mode.

In enable imbalance detection mode, drive execute imbalance detect operation when each media insertion. Through drive initial-time will be increase several seconds, and drive enable to limit rotate-speed for low self-vibration.

5.17 PREVENT ALLOW MEDIUM REMOVAL command

	7	6	5	4	3	2	1	0	NOTE	
00	Operation Code								1Eh	
01	LUN									00h
02									00h	
03	Reserved								00h	
04							Persistent	Prevent		
05							Flag	Link		
06									—	
07									—	
08	PAD								—	
09									—	
10									—	
11									—	

COMMAND FUNCTION

Request the drive to enable or disable the medium removal.

The operation is persistent then the prevent will not be reset when media is removed or inserted. This will allow new media to become captive without host interaction. The Persistent Prevent is to be used in conjunction with the GET EVENT STATUS NOTIFICATION command, to prevent media from being ejected with dirty file system buffers.

< Command Type > : Mandatory (Removable / Morphing)

- <Persistent> : Persistent bit of **one** directed to indicate persistent operation.
Persistent bit of **zero** directed to without persistent operation.
- <Prevent> : Prevent bit of **one** directs to inhibit the removal of the media.
Prevent bit of **zero** directs to allow removal.

DESCRIPTION

This command requests the DVD-ROM drive to enable or disable the medium removal (Tray Open operation : command / eject switch). Prevent bit of **one** directs the DVD-ROM drive to inhibit the medium removal. The prevention status begins when the Host Computer issues a PREVENT ALLOW MEDIUM REMOVAL command with Prevent bit set to **one**.

The prevention status remain in effect until following events occurs.

- 1) A RESET condition is occurs.
- 2) The initiator issues a PREVENT ALLOW MEDIUM REMOVAL command with Prevent bit set to **zero**.

5.17.1 Persistent Prevent Operation

Persistent bit indicates that this will be a persistent prevent/allow status.

The persistent prevention status begins when the Host Computer issues a PREVENT ALLOW MEDIUM REMOVAL command with Persistent bit and Prevent bit set to **one**. The DVD-ROM drive is disable hardware eject mechanisms, is remain locked in the drive until the host issue an eject request, or persistent prevent status is reset and the hardware eject mechanism again becomes available.

The persistent prevention status remain in effect until following events occurs.

- 1) A Hard RESET(Power-ON or $\overline{\text{RESET}}$) condition is occurs.
- 2) The initiator issues a PREVENT ALLOW MEDIUM REMOVAL command with Persistent bit set to **one** and Prevent bit set to **zero**.

5.18 READ FORMAT CAPACITIES command

	7	6	5	4	3	2	1	0	NOTE	
00	Operation Code								23h	
01	LUN									00h
02									00h	
03	Reserved								00h	
04									00h	
05									00h	
06									00h	
07	(MSB) Allocation Length									
08									(LSB)	
09	Reserved						Flag	Link		
10	PAD								—	
11									—	

COMMAND FUNCTION

Request the drive to transfer the information regarding the media capacity²⁶.

< Command Type > : Mandatory (SFF-8090)
 : Optional (SFF-8090v2/v3, Formattable)

< Allocation Length > : Maximum number of bytes that the Host Computer has allocated for returned sense data.

DESCRIPTION

This command requests the DVD-ROM drive to transfer a list of the possible media capacities for an installed media

	7	6	5	4	3	2	1	0	NOTE
	<i>Capacity List Header</i>								
00									00h
01	Reserved								00h
02									00h
03	Capacity List Length								08h
	<i>Current/Maximum Capacity Header</i>								
04	(MSB)								/00h
05	Number of Blocks								/FFh
06									/FFh
07									(LSB) /FFh
08	Reserved						Descriptor Type		02/03h
09	(MSB)								00h
10	Block Length								08h
11									(LSB) 00h

Table 5.39: Read Formatted Capacities Data Format

Capacity List Length specifies the length in bytes of the Capacity Descriptors that follow. Each Capacity Descriptor is eight bytes in length, making the capacity list Length equal to eight times the number of descriptors.

²⁶**Media Capacity**: possible capacity

The DVD-ROM drive does not support write function. Thus, no additional Formattable Capacity information data return, capacity list length always indicate 08h.

Number of Blocks indicates the maximum (or fixed) number of addressable blocks for the descriptor's media type.

When no media installed, drive report Number of Blocks information is 00FFFFFFh.

Descriptor Type indicate medium installed or not.

DESCRIPTOR TYPE	DESCRIPTION	
00b	<i>Reserved</i>	
01b	Unformatted Media.	ROM device is not support.
10b	Formatted Media.	The reported value is the current media's capacity
11b	No Media present.	The reported value is for the Maximum formattable capacity for any media

Block Length specifies the length in bytes of each logical block for the descriptor's media type.

The DVD-ROM drive indicate 000800h, 2048bytes/block.

5.19 READ CAPACITY command

	7	6	5	4	3	2	1	0	NOTE
00	Operation Code								25h
01	LUN				RelAdr				00h
02									00h
03									00h
04									00h
05	Reserved								00h
06									00h
07									00h
08									PMI
09							Flag	Link	
10	PAD								—
11									—

COMMAND FUNCTION

Request the drive to transfer the information regarding the capacity of the medium.

< Command Type > : Mandatory (SFF-8020/8020i/8090v2/v3, Removable)
: Optional (SFF-8090)

< RelAdr > : RelAdr²⁷bit is not used by drive and should be set to **zero**.

< PMI > : PMI²⁸bit is not used by drive and should be set to **zero**.

DESCRIPTION

This command requests the DVD-ROM drive to transfer the information regarding the capacity of the medium and block length.

The drive returns the last logical block address information of the media.

	7	6	5	4	3	2	1	0	NOTE	
00	(MSB)									
01	Logical Block Address									
02										
03								(LSB)		
04	(MSB)	Block Length								00h
05									00h	
06									08h	
07								(LSB)	00h	

Table 5.40: Read Capacity Data Format

When CD media installed the drive:

Note: That the block may not be readable or playable, since it may be in a transition (gap) area prescribed in CD-ROM standard.

²⁷RelAdr: Relative Address

²⁸PMI: Partial Medium Indicator

The last logical block address can be calculated from following formula with TOC²⁹ data that is prescribed in CD standard.

$$\text{LastLogicalBlockAddress} = (\text{Min}_{\text{leadout}} \times 60 \times 75 + \text{Sec}_{\text{leadout}} \times 75 + \text{Frame}_{\text{leadout}} - 150) - 1$$

Accordingly, if a medium consists of only CD-ROM data track, this last logical block address shows the total data capacity except for the first pre-gap area (150 physical blocks). However note that this address does not show the correct data capacity when a medium contains CD-ROM data and CD-DA track.

Table 5.40 shows the READ CAPACITY data format consisting of eight byte which is transferred during data transfer.

The Block Length field always indicates the block length in bytes (2048 bytes).

²⁹TOC: Table of Contents

5.20 READ(10) command

	7	6	5	4	3	2	1	0	NOTE
00	Operation Code								28h
01	LUN			DPO	FUA	Reserved		RelAdr	00/08h
02	(MSB)								
03	Logical Block Address								
04									
05									(LSB)
06	Reserved								00h
07	(MSB) Transfer Length								
08									(LSB)
09	Reserved						Flag	Link	
10	PAD								—
11									—

COMMAND FUNCTION

Request the drive to transfer read data specified by the logical block address and transfer length.

< Command Type > : Mandatory (Random Readable)

<DPO > : DPO³⁰ bit is not used by drive and should be set to **zero**.

<FUA > : FUA³¹ bit is indicate to use cache or not.

<RelAdr > : RelAdr bit is not used by drive and should be set to **zero**.

< Logical Block Address > : The logical block address at which the read operation shall begin.

< Transfer Length > : The number of logical block to be transferred.

DESCRIPTION

This command requests the DVD-ROM drive to transfer data specified by logical block address and transfer length.

This command is available for all density codes including CD-DA transfer mode.

DPO bit is not used by DVD-ROM drive and should be set to **zero**. A DPO bit of **zero** indicates the priority is determined by the retention priority fields in the cache page if supported.

FUA bit of **one** indicates that the DVD-ROM drive access the media in performing the command. Read commands access the specified logical blocks from the media (i.e. the data is not directly retrieved from the cache).

FUA bit of **zero** indicates that the DVD-ROM drive may satisfy the command by accessing the cache memory. For read operations any logical blocks that are contained in the cache memory may be transferred to the Host directly from the memory.

Logical Block Address field specifies the logical block address at which the read operation shall begin.

Transfer Length field specifies the number of contiguous logical blocks of data that are transferred during DATA IN phase. A transfer length of **zero** indicates that no logical blocks are transferred. This condition is not considered an error. Any other value indicates the number of logical blocks that are transferred.

The transfer data format (Block Length, CD-ROM XA selection etc.) or error recovery parameters are specified by the MODE SELECT command issued prior to the READ command.

Regarding these parameters, refer to Section 5.10 MODE SELECT command.

³⁰DPO : Disable Page Out

³¹FUA : Force Unit Access

5.21 SEEK(10) command

	7	6	5	4	3	2	1	0	NOTE
00	Operation Code								2Bh
01	LUN			Reserved					00h
02	(MSB)								
03	Logical Block Address								
04									
05									
06									00h
07	Reserved								00h
08									00h
09							Flag	Link	
10	PAD								—
11									—

COMMAND FUNCTION

Request the DVD-ROM drive to seek to the specified logical block address.

< Command Type > : Mandatory (CD Audio, Analog Play)

< Logical Block Address > : Specifies the logical block address at which the seek operation is executed.

DESCRIPTION

This command requests the DVD-ROM drive to seek to the specified logical block address.

All logical block addresses are able to be targets for a SEEK operation including a CD-DA audio sector.

In the case of C/DVD-ROM data sector, the seek operation of DVD-ROM drive is defined as an operation to seek to the specified address.

In the case of CD-DA audio sector, the DVD-ROM drive seeks to the address using the subcode-Q address.

The Logical Block Address field specifies the logical block address at which the seek operation is executed.

5.22 WRITE BUFFER command

	7	6	5	4	3	2	1	0	NOTE
00	Operation Code								3Bh
01	LUN			Reserved		Mode			05h
02	Buffer ID								00h
03	(MSB)								
04	Buffer Offset								
05	(LSB)								
06	(MSB)								
07	Parameter List Length								
08	(LSB)								
09	Reserved					Flag	Link		
10	PAD								—
11									—

COMMAND FUNCTION

Request the DVD-ROM drive is available for downloading microcode that updates the firmware of the DVD-ROM drive stored in a flash PROM.

< Command Type > : Optional

< Mode > : Specifies the function of this command and 101b (Download microcode and save mode).

< Buffer ID > : Should be set to **zero**.

< Buffer Offset > : Specifies the starting address in the buffer at which the write operation shall begin.

< Parameter List Length > : Specifies the length in bytes that shall be transferred during DATA OUT phase.

DESCRIPTION

This command requests the DVD-ROM drive to download microcode that updates the firmware of the DVD-ROM drive stored in a flash PROM.

Buffer ID field identifies a specific buffer within the target. As the DVD-ROM drive supports ID of **zero**, it returns **CHECK CONDITION** status with additional sense code set to **INVALID FIELD IN CDB** if Buffer ID is not **zero**.

Buffer Offset field specifies the starting address at which the write buffer operation shall begin.

Parameter list length field specifies the length in bytes that shall be transferred during DATA OUT phase.

Downloading microcode function is basically for factory use, so the transfer data format which includes some security code is not disclosed with this SCSI interface specification.

5.23 READ SUB-CHANNEL command

Audio CD medium installed only valid.

	7	6	5	4	3	2	1	0	NOTE
00	Operation Code								42h
01	LUN					MSF		00/02h	
02	Reserved	SubQ	Reserved						00/40h
03	Sub-channel Data Format								
04	Reserved								00h
05									00h
06	Track Number								
07	(MSB)	Allocation Length							
08								(LSB)	
09	Reserved						Flag	Link	
10	PAD								—
11									—

COMMAND FUNCTION

Request the drive to transfer the requested sub-channel data plus the audio playback operation status.

< Command Type > : Mandatory (CD Audio, Analog Play)

<MSF> : MSF bit of **zero** indicates that the logical block address format should be used for the CD-ROM address field. MSF bit of **one** indicates that MSF format should be used.

<SubQ> : SubQ³² bit of **one** indicates that the DVD-ROM drive should return the Q sub-channel data.

<Sub-channel Data Format > : Specifies the format of returned sub-channel data.

< Track Number > : Specifies the track number from which ISRC³³ data is read.

< Allocation Length > : Maximum number of bytes that the Host Computer has allocated for returned sub-channel data.

DESCRIPTION

This command requests the DVD-ROM drive to transfer the requested sub-channel (subcode-Q address data) and current status of audio playback operation. MSF bit set to **zero** indicates that the logical address format is used for the CD-ROM address field in returned sub-channel data. MSF bit set to **one** indicates that the MSF address format is used. However note that this MSF format is different from the address format of CD or CD-ROM standard. For instance, the **Min** field has a value between 00h to 63h (99d) while it has a value between 00h to 99h in CD standard and so on.

SubQ bit of **one** indicates that audio playback status plus Q sub-channel data to be returned.

SubQ bit of **zero** indicates that only audio playback status (sub-channel data header) to be returned.

Sub-channel Data Format field specified the data format of the sub-channel data to be returned.

Track Number field specifies the track number from which ISRC data (ADR 3 data) is read and this field is only valid when Sub-channel Data Format field is set to 03h. If this field is non-**zero** for the Data Format other than 03h, the DVD-ROM drive returns a CHECK CONDITION status with INVALID FIELD IN COMMAND PACKET error code.

³²SubQ: Subcode-Q

³³ISRC: International Standard Recording Code

DATA FORMAT	RETURNED DATA FORMAT
00h	<i>Reserved</i>
01h	Current Position
02h	Media Catalog Number (UPC/Bar Code)
03h	Track International-Standard-Recording-Code (ISRC)
04h - EFh	<i>Reserved</i>
F0h - FFh	<i>Not Used</i>

Table 5.41: Sub-channel Data Format

Allocation length field specifies the maximum number of bytes that the Host Computer has allocated for the returned sub-channel data. The DVD-ROM drive terminates the data transfer when the allocation length bytes have been transferred or when all available sub-channel data have been transferred to the Host Computer, whichever is less.

The sub-channel data consists of 4 bytes header followed by a sub-channel data block. The sub-channel data header consists of audio playback status field and sub-channel data length field as follow.

	7	6	5	4	3	2	1	0	NOTE
00	<i>Reserved</i>								00h
01	Audio Status								
02	(MSB)	Sub-channel Data Length							
03								(LSB)	

Table 5.42: Sub-channel Data Header

Audio Status field indicates the current status of audio playback operation. Status 00h is returned if the Host Computer has not issued valid audio playback command to the DVD-ROM drive .

Status 11h to 15h is returned when an audio playback command was issued. 11h and 12h is used during audio playback operation. 13h and 14h is prepared when the audio playback operation stopped and these status are returned only once after the condition has occurred. After returning 13h or 14h, the DVD-ROM drive returns 15h to subsequent READ SUB-CHANNEL commands.

STATUS	DESCRIPTION
00h	Audio status byte not valid.
11h	Audio play operation in progress.
12h	Audio play operation paused.
13h	Audio play operation successfully completed.
14h	Audio play operation stopped due to error.
15h	No current audio status to return.

Table 5.43: Audio Status Code

Sub-channel Data Length field specifies the length in bytes of the following sub-channel data block. If SubQ bit is set to **zero**, the DVD-ROM drive does not return following sub-channel data block and set sub-channel data length field to **zero**. Table 5.44,5.47 and 5.48 show three kinds of sub-channel data format.

5.23.1 CD-ROM Current Position Data (Format 01h)

	7	6	5	4	3	2	1	0	NOTE
00	<i>Reserved</i>								00h
01	Audio Status								refer to 5.43
02	(MSB)	Sub-channel Data Length						(LSB)	00h
03									0Ch
04	Sub-channel Data Format Code								01h
05	ADR				Control				
06	Track Number								
07	Index Number								
08	(MSB)	Absolute CD-ROM Address						(LSB)	
09									
10									
11									(LSB)
12	(MSB)	Track Relative CD-ROM Address						(LSB)	
13									
14									
15									(LSB)

Table 5.44: Current Position Data

The Sub-Q Channel Data block consists of current data. Current data is obtained from the Q sub-channel information of the current block. If the audio playback operation is in progress in the background mode, current position for the last played is reported.

ADR field shows the type of information encoded in the Q sub-channel of this block that is prescribed in CD standard.

ADR	DESCRIPTION
00h	Sub-channel Q mode information not supplied.
01h	Sub-channel Q encodes current position data.
02h	Sub-channel Q encodes media catalog number.
03h	Sub-channel Q encoded ISRC.
04 - 0Fh	<i>Reserved</i>

Table 5.45: ADR Field

Control field shows the kinds of information in a track defined in CD standard as shown in Table 5.46.

Track Number field specifies the current track number, which is a sub-division of a disc.

Index Number field specifies the current index number, which is a sub-division of a track.

Absolute CD-ROM Address field shows the current location relative to the beginning of the media, or elapsed time on the media. If MSF bit is **zero**, logical block addressing is used, and if MSF bit is **one**, absolute MSF addressing is used.

Track Relative CD-ROM Address field shows the current location relative to the logical beginning of the current track, or running time within the current track. If MSF bit is **zero**, track

BIT	DEFINITION	
	<i>Equals zero</i>	<i>Equals one</i>
0	Without Pre-Emphasis	With Pre-Emphasis
1	Digital Copy Prohibited	Digital Copy Permitted
2	Audio Track	Data Track
3	2 Audio Channels	4 Audio Channels

Table 5.46: Control Field

relative logical block addressing is used, and if current location is in pre-gap area of the track (Index Number is **zero**), negative value expressed as a two's complement is returned. If MSF bit is **one**, relative MSF addressing is used.

5.23.2 Media Catalog Number Data (Format 02h)

	7	6	5	4	3	2	1	0	NOTE
00	<i>Reserved</i>								00h
01	Audio Status								refer to 5.43
02	(MSB) Sub-channel Data Length								00h
03									14h
04									02h
05	Sub-channel Data Format Code (=02h)								00h
06	<i>Reserved</i>								00h
07									00h
08	MCVa1								00/80h
09	N ₁ (Most Significant)								
10	N ₂								
11	N ₃								
12	N ₄								
13	N ₅								
14	N ₆								
15	N ₇								
16	N ₈								
17	N ₉								
18	N ₁₀								
19	N ₁₁								
20	N ₁₂								
21	N ₁₃								
22	Zero								
23	AFrame (Binary)								

Table 5.47: Media Catalog Number Data Format

The Media Catalog Number Data block consists of the identification data of a disc. MCVa1³⁴ bit of **one** indicates that the Media Catalog Number field is valid. MCVa1 bit of **zero** indicates that the Media Catalog Number field is not valid. The media catalog number is used as the UPC/EAN code (Bar code) expressed in 13 digits BCD.

Returned UPC data is encoded as ASCII characters. For instance, if N₁ of UPC is 01b, N₁ of above

³⁴MCVa1: Media catalog valid

field is converted to 31h (49d). The catalog number does not change on a disc. As the UPC is contained in 1 out of 100 sectors and error may be encountered, it is recommend that audio playback be executed for several seconds to get UPC data correctly.

5.23.3 Track ISRC Data (Format 03h)

	7	6	5	4	3	2	1	0	NOTE
00	Reserved								00h
01	Audio Status								refer to 5.43
02	(MSB) Sub-channel Data Length								00h
03	(LSB)								14h
04	Sub-channel Data Format Code (=03h)								03h
05	ADR				Control				
06	Track Number								
07	Reserved								00h
08	TCVal								00/80h
09				I ₁		(Country Code)			
10				I ₂					
11				I ₃		(Owner Code)			
12				I ₄					
13				I ₅					
14				I ₆		(Year of Recording)			
15				I ₇					
16				I ₈		(Serial Number)			
17				I ₉					
18				I ₁₀					
19				I ₁₁					
20				I ₁₂					
21	Zero								
22	AFrame				(Binary)				
23	Reserved								00h

Table 5.48: Track ISRC Data Format

The Track ISRC Data block consists of the identification data of a track. TCVal³⁵ bit of **one** indicates that the track ISRC field is valid. TCVal bit of **zero** indicates that the track ISRC field is not valid. The track ISRC is used to give a unique number to a track by ISRC defined in DIN-31-621. The ISRC only changes immediate after the track number has been changed. I₁, I₂ are the country code and I₃, I₄, I₅ are the owner code. I₁ through I₅ are coded in a 6-bit format. I₆, I₇ are the year of recording and I₈ through I₁₂ are the serial number of the recording. The characters from I₆ are 4-bit BCD number and are encoded as ASCII character.

As well as mode-2 (UPC), it is recommend that audio playback be executed for several seconds to get ISRC data correctly.

³⁵TCVal: Track code valid

5.24 READ TOC/PMA/ATIP command

CD medium installed only valid.

	7	6	5	4	3	2	1	0	NOTE
00	Operation Code								43h
01	LUN			Reserved			MSF	Reserved	00/02h
02	Reserved				Format ^{MMC} Reserved ^{SCSI-2}				
03									00h
04	Reserved								00h
05									00h
06	Track Number / Session Number								
07	(MSB) Allocation Length								
08									(LSB)
09	Reserved ^{MMC} Format ^{SCSI-2}		Reserved						
10	PAD								—
11									—

COMMAND FUNCTION

Request the DVD-ROM drive to transfer TOC data and multi-session data to the host.

The DVD-ROM drive does not support PMA³⁶ / ATIP³⁷ data format.

For DVD media, as there is no TOC, this command will fabricate information that is similar to that of CD media. This fabrication is required for some legacy Host environments.

< Command Type > : Mandatory (CD Read, DVD Read)

<MSF> : MSF bit of **zero** indicates that the logical block address format is used for the CD-ROM address field.
MSF bit of **one** indicates that MSF format is used.

< Track / Session Number > : Specifies the starting track number or session number for which the TOC data is returned.

< Allocation Length > : Maximum number of bytes that the Host Computer has allocated for the returned READ TOC/PMA/ATIP data.

< Format > : Type of information to be return.

DESCRIPTION

This command requests the DVD-ROM drive to transfer the TOC data which is prescribed in CD standard to the Host Computer. As Toshiba drive caches the TOC data, it is able to return data immediately upon this command.

MSF bit defines the addressing mode. Refer to section 5.23 READ SUB-CHANNEL command for the description MSF bit.

Track / Session Number field specifies the starting track number (TNO) or session number for which the TOC data is returned. For the Format of 0000b, this field specifies the starting track and must have a value between 00h to 63h (99d) and a value of **zero** specifies that the TOC data from first track on the medium is returned. If the starting track number is not valid for currently installed medium, a CHECK CONDITION status is returned.

For the Format of 0000b and 0010b, this field specifies the starting session number. Others, this field is ignored.

³⁶PMA: Program Memory Area

³⁷ATIP: Absolute Time In Pre-grove

0000b	The first/last track number and TOC data for each track
0001b	The first/last session number and the last session starting address
0010b	All subcode-Q data in TOC area
0011b	<i>Not Support (PMA)</i>
0100b	<i>Not Support (ATIP)</i>
0101b	All CD Text Data in TOC area
<i>Other</i>	<i>Reserved</i>

Table 5.49: Read TOC/PMA/ATIP Format field definition

Allocation length field specifies the maximum number of bytes that the Host Computer has allocated for the returned TOC data . The DVD-ROM drive terminates the data transfer when the allocation length bytes have been transferred or when all available TOC data have been transferred

The READ TOC/PMA/ATIP data consists of 4 bytes header followed by zero or more TOC Track Descriptors and the Format field specifies the type of information to be returned as follows.

5.24.1 Track Number Data (Format 0000b)

	7	6	5	4	3	2	1	0	NOTE
00	(MSB) TOC Data Length								
01									(LSB)
02	First Track Number (00 - 63h)								
03	Last Track Number (00 - 63h)								
	<i>TOC Track Descriptors</i>								
00	Reserved								00h
01	ADR				Control				
02	Track Number								
03	Reserved								00h
04	(MSB)								
05	Absolute Address								
06									
07									(LSB)

Table 5.50: Read TOC/PMA/ATIP Data (Format 0000b)

TOC Data Length field specifies the length in bytes of the following TOC data and it does not include the TOC Data Length field itself.

First Track Number field indicates the first (minimum) track number of the installed medium which has a value between 01h to 63h (99d).

Note: That the first track number is not required to be one and a medium may start at any valid (BCD) track number.

Last Track Number field indicates the last (maximum) track number of the installed medium which has a value between 01h to 63h (99d).

ADR and Control field indicates the type of information or attributes which denotes each track. For further details, refer to 5.23 READ SUB-CHANNEL command.

Track Number field indicates the track number for each TOC Track Descriptor. TOC data is returned in contiguous ascending track number order and TOC Track Descriptor of the lead-out area (Track Number field is AAh) is returned last.

Absolute CD-ROM Address field indicates the address of the first block with user information (Index 01) for that track. Logical block addressing is used for MSF bit set to **zero** and MSF absolute addressing is used for MSF bit set to **one**.

Note: That CD and CD-ROM standard allows that this starting address value has a tolerance of plus/minus one second for audio tracks and zero for data tracks.

For multi-session photo-CD, the CD-ROM reconstructs TOC data for all sessions and this command returns the TOC data for all sessions.

5.24.2 Session Number Data (Format 0001b)

	7	6	5	4	3	2	1	0	NOTE
00	(MSB) TOC Data Length								00h
01									(LSB) 0Ah
02	First Session Number (00 - 63h)								
03	Last Session Number (00 - 63h)								
<i>TOC Track Descriptor</i>									
00 (04)	Reserved								00h
01 (05)	ADR				Control				
02 (06)	First Track Number in Last Session								
03 (07)	Reserved								00h
04 (08)	(MSB)								
05 (09)	Absolute Address								
06 (10)	of First Track in Last Session								
07 (11)									(LSB)

Table 5.51: Read TOC/PMA/ATIP Data (Format 0001b)

TOC Data Length field is fixed to be 0Ah (10d).

First Session Number field indicates the first (minimum) session number of the installed medium which has a value between 01h to 63h (99d).

Last Session Number field indicates the last (maximum) session number of the installed medium which has a value between 01h to 63h (99d). The First Session Number is equal to the Last Session Number for a single session disc.

First Track Number in Last Session field indicates the starting track number in last session.

Absolute CD-ROM Address field of First Track in Last Session indicates the address of the starting block of the first track in last session, namely, it indicates the offset of last session.

There exists a CD-I disc having special structure that there is no track (point) information (has only 00h or AAh track). In the case of such disc, the TOC track descriptor shows the information of Lead-Out track.

5.24.3 Subcode-Q Data (Format 0010b)

For the Format of 0010b, the DVD-ROM drive returns all TOC data for subcode-Q mode 1 and 5 (except for point 1 through 40) in the TOC area. TOC Data Length field (Byte 00 and 01) specifies the length in bytes of the following TOC data and it does not include the TOC Data Length field itself.

	7	6	5	4	3	2	1	0	NOTE
00	(MSB) TOC Data Length								
01									(LSB)
02	First Session Number (00 - 63h)								
03	Last Session Number (00 - 63h)								
	<i>TOC Track Descriptor</i>								
00	Session Number								
01	ADR				Control				
02	Byte 1			or	TNO				
03	Byte 2			or	Point				
04	Byte 3			or	Min				
05	Byte 4			or	Sec				
06	Byte 5			or	Frame				
07	Byte 6			or	Zero				
08	Byte 7			or	PMin				
09	Byte 8			or	PSec				
10	Byte 9			or	PFrame				

Table 5.52: Read TOC/PMA/ATIP Data (Format 0010b)

TOC Data Length field specifies the length in bytes of the following TOC data and it does not include the TOC Data Length field itself.

First Session Number field indicates the first (minimum) session number of the installed medium which has a value between 01h to 63h (99d).

Last Session Number field indicates the last (maximum) session number of the installed medium which has a value between 01h to 63h (99d).

The First Session Number is equal to the Last Session Number for a single session disc.

The returned TOC data of a multi-session disc is arranged in ascending order of the session number and Session Number field (Byte 00 in TOC Track Descriptor) indicates the number. The TOC data within a session is arranged in the order of Subcode-Q point field value of A0h, A1h, A2h, Track Numbers, B0h, B1h, B2h, B3h, B4h and C0h.

The information specified with the point field is defined as follows.

00 - 99h	(Mode-1)	Starting point of track
A0h	(Mode-1)	First track number in the program area and Disc identifier
A1h	(Mode-1)	Last track number in the program area
A2h	(Mode-1)	Starting address of the Lead-out area
B0h	(Mode-5)	Starting address of next possible program area and maximum starting address of the outermost Lead-out area
B1h	(Mode-5)	Number of Skip Interval Pointers and Skip Track assignments
01 - 40h	(Mode-5)	Skip Interval Pointers <i>Note that this information is not included in the TOC data</i>
B2 - B4h	(Mode-5)	Skip Track Assignment Pointers
C0h	(Mode-5)	Starting address of first Lead-in area of Hybrid disc
C1h	(Mode-5)	This pointer gives additional information about CD-R/RW

For details, refer to CD RED BOOK and CD-ROM ORANGE BOOK specification.

5.24.4 CD Text Data (Format 0101b)

	7	6	5	4	3	2	1	0	NOTE	
00	(MSB)	TOC Data Length								
01								(LSB)		
02		Reserved							00h	
03									00h	
		<i>CD TEXT Pack Descriptor</i>								
00	(MSB)	Header								
01										
02										
03								(LSB)		
04	(MSB)	Text Data (ASCII)								
⋮									⋮	
15								(LSB)		
16	(MSB)	CRC								
17								(LSB)		

Table 5.53: Read TOC/PMA/ATIP Data (Format 0101b)

For the Format of **x101b**, the DVD-ROM drive returns all text information data from the subcode channels R-W in the Lead-In area of CD-DA disc (if exist), such as album name, artist names, track titles, etc.

TOC Data Length field specifies the length in bytes of the following TOC data and it does not include the TOC Data Length field itself.

Header field consists of 4 indicator (ID) bytes : ID1 (Pack Type indicator), ID2 (Track Number indicator), ID3 (Sequence Number indicator) and ID4 (Block Number and Character Position indicator).

Text Data field consists of 12 bytes, and either contents character string or binary information depending on the type of Pack.

CRC³⁸ field consists of 2 bytes, MSB first, and is used to check errors in R to W channels in the Lead-In Area.

The CRC polynomial is $X^{16} + X^{12} + X^5 + 1$. All bits are inverted.

³⁸CRC : Cyclic Redundancy Checksum

Text Group, Block and Pack

A set of text information representing one particular language is called a Block. A Block can contain up to 256 Packs. Up to 8 blocks are combined into a Text Group. The size of a Text Group is recommended to be less than 512 Packs, and shall be at maximum 2048 Packs.

Text Groups shall be recorded repeatedly in the Lead-In Area:

CD TEXT Pack format for the Lead-In Area

A Pack consists of a Header field, a Text Data Field and a CRC field.

Description of ID1 (Pack Type Indicator) ID1 shows the items that are encoded in the Pack. Items are defined as follows:

ID1	ITEM
80h	Title of album name (ID2=00h) and Track Titles (ID2=01h..63)h
81h	Name(s) of the performer(s) (<i>i.e.</i> singer(s) and/or player(s) and/or conductor(s) and/or the orchestra(s))
82h	Name of the songwriter(s)
83h	Name of the composer(s)
84h	Name of the arranger(s)
85h	Message(s) from content provider and/or artist
86h	Disc Identification information
87h	Genre Identification and Genre information
88h	Table of Content information
89h	Second Table of Content information
8Ah	<i>Reserved</i>
8Bh	
8Ch	
8Dh	Closed information (for internal use by content provider only)
8Eh	UPC/EAN code of the album, and ISRC code of each track
8Fh	Size information of the Block

Packs must be encoded in the significant bits of ID1 are 100b, this corresponds with an indication of Mode 4.

Description of ID2 (Track Number Indicator) ID2 contains 1 bit of the Extension flag, and 7 bits of either Track Number or Pack Element Number.

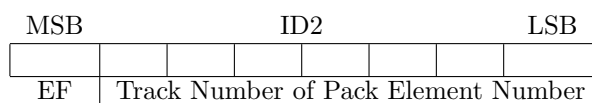

EF : Extension flag The MSB of ID2 is the Extension flag, and is normally set to **zero**. If it is set to **one**, the Pack is used for an extended application (to be defined).

Track Number The lower 7 bits of ID2 show the Track Number to which the first character of the Text Data field of the Pack (Text1) belongs. The track number (1 to 99) is expressed in binary code (0000001b to 1100011b). Track number 0000000b is used for information that represents the whole disc (Album name, main performer, main composer, main message, main songwriter, main arranger, etc.). Track numbers 1100100b up to and including 1111111b are reserved.

Pack Element Number Packs that are independent of the Tracks use the lower 7 bits of ID2 to indicate the Pack Element Number. The use of this field depends on the type of the Pack.

Description of ID3 (Sequence Number indicator) ID3 contains the Sequence Number of Pack, numbered incrementally from the first Pack in each Block. The Sequence Number starts at 0 (00h) and must not exceed 255 (FFh).

Description of ID4 (Block number and Character Position indicator) ID4 contains 1 bit of the Double Byte Character Code indication, 3 bits of the Block Number and 4 bits of the Character Position.

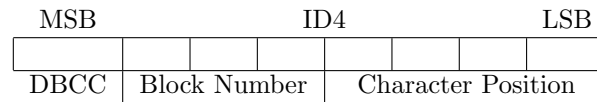

Double Byte Character Code indication The most significant bit of ID4 is the Double Byte Character Code indication. If a block contains Double Byte Character strings in the Text Data Field of Packs with ID1 = 80h through 85h, all Packs within the block must have their Double Byte Character Code indication set to **one**. In all other cases it shall be set to **zero** to indicate a Single Byte Character Code is used.

Block Number The next 3 bits of ID4 contain the Block Number if the Block to which the Pack belongs. Block Number is numbered incrementally from 0 from the first Block within each Group.

Character Position The least significant 4 bits of ID4 contain the Character Position. The position of the first character of the Text Data field (Text1) is counted from the first character of its string. The Character Position starts from 0, and if the position exceeds 15, 15 shall be encoded. When the character code is a double byte code, a set of 2 bytes in the Text Data field (*i.e.* each double byte character) is counted as one. A null code is also counted as a character, when obtaining the Character Position. Character Position is not used in Packs with ID1 = 88h, 89h or 8Fh, and 0000b should be used in all of these Packs.

For more details, refer to CD TEXT specification.

5.25 READ HEADER command

CD medium installed only valid.

	7	6	5	4	3	2	1	0	NOTE
00	Operation Code								44h
01	LUN			Reserved			MSF	Reserved	00/02h
02	(MSB)								
03	Logical Block Address								
04									
05									(LSB)
06	Reserved								00h
07	(MSB)								
08	Allocation Length								
09	Reserved						Flag	Link	
10	PAD								—
11									—

COMMAND FUNCTION

Request the drive to transfer CD-ROM header address data of the specified block to the initiator.

< Command Type > : Mandatory

< MSF > : MSF (Min/Sec/Frame) bit of **zero** indicates that the logical block address format is used for the CD-ROM address field. MSF bit of **one** indicates that MSF format is used.

< Logical Block Address > : The logical block address at which the read header operation is executed.

< Allocation Length > : Maximum number of bytes that the Host Computer has allocated for the returned READ HEADER data.

DESCRIPTION

This command requests the DVD-ROM drive to transfer CD-ROM header address data of the specified block to the Host Computer. MSF bit defines the addressing mode. Refer to 5.23 READ SUB-CHANNEL command for the description of MSF bit.

Logical block address specifies the logical block at which read header operation is executed.

Allocation length field specifies the maximum number of bytes that the Host Computer has allocated for the returned READ HEADER data. The DVD-ROM drive terminates the data transfer when the allocation length bytes have been transferred or when all available READ HEADER data have been transferred to the Host Computer, whichever is less.

Table 5.54 shows the READ HEADER data format.

CD-ROM Data Mode field specifies the CD-ROM mode data in the specified block. The values are defined in CD-ROM standard as shown in Table 5.55

If MSF bit is set to **zero**, the absolute CD-ROM Address field shows the logical block address that is same as the specified block in the Command Packet. If MSF bit is set to **one**, the absolute CD-ROM Address field indicates the MSF address where the specified logical block is found.

	7	6	5	4	3	2	1	0	NOTE
00	CD-ROM Data Mode								
01									00h
02	Reserved								00h
03									00h
04	(MSB)								
05	Absolute Address								
06									
07								(LSB)	

Table 5.54: READ HEADER Data Format

CD-ROM MODE	DESCRIPTION
00h	Consists of all zero data
01h	Consists of user data (2048 bytes) plus ECC/EDC data(288 bytes)
02h	Consists of user data (2336 bytes)
03 - FFh	<i>Reserved</i>

Table 5.55: CD-ROM Mode

5.26 PLAY AUDIO(10) command

Audio CD medium installed only valid.

	7	6	5	4	3	2	1	0	NOTE
00	Operation Code								45h
01	LUN			Reserved					00h
02	(MSB)								
03	Starting Logical Block Address								
04									
05									(LSB)
06	Reserved								00h
07	(MSB) Transfer(Play) Length								
08									(LSB)
09	Reserved					Flag	Link		
10	PAD								—
11									—

COMMAND FUNCTION

Request the drive to begin an audio playback operation from the specified logical block address.

< Command Type > : Optional (CD Audio, Analog Play)

< Starting Logical Block Address > : Specifies the block address at which the audio playback operation shall begin.

< Transfer Length > : The number of logical blocks to be played.

DESCRIPTION

This command requests the DVD-ROM drive to search and start an audio playback operation from the specified starting logical block address and to complete audio playback when specified blocks have been played.

Starting Logical Block Address field specifies the block address at which the audio playback operation shall begin. PLAY AUDIO commands with a logical block address of FFFFFFFFh requests to start audio playback from current location of the optical head.

If the requested logical block address is not in audio track, the DVD-ROM drive terminates the command and returns CHECK CONDITION status. The sense key is set to ILLEGAL REQUEST and the additional sense code is set to ILLEGAL MODE FOR THIS TRACK.

Transfer length field specifies the number of logical blocks to be played.

When SOTC bit in Audio Control parameters page is set to **zero**, the DVD-ROM drive terminates the audio playback operation when the requested transfer length is played.

When SOTC bit is set to **one**, the DVD-ROM drive terminates the audio playback operation either when the beginning of next track (Index 0 or 1) is encountered or when the requested transfer length is played.

A transfer length of **zero** indicates that no audio playback shall occur. If the DVD-ROM drive encounters data track during audio playback operation, it terminates the audio playback operation.

As well as PLAY AUDIO command, the DVD-ROM drive returns a status as soon as the audio playback starts.

Note: That the Host Computer is able to recognize the command completion (Audio playback completion) with a READ SUB-CHANNEL or REQUEST SENSE command.

5.27 GET CONFIGURATION command

	7	6	5	4	3	2	1	0	NOTE
00	Operation Code								46h
01	LUN			Reserved			RT		
02	(MSB) Starting Feature Number								
03									(LSB)
04									00h
05	Reserved								00h
06									00h
07	(MSB) Allocation Length								
08									(LSB)
09	Reserved						Flag	Link	
10	PAD								—
11									—

COMMAND FUNCTION

This command is intended to provide information to the host about the overall capabilities of the device and the current capabilities of the device.

< Command Type > : Mandatory (Core)

< RT > : RT³⁹ field indicates the set of Feature Descriptors desired from the drive.

< Starting Feature Number > : SFN⁴⁰ indicates the first feature number to be returned.

< Allocation Length > : Maximum number of bytes that the Host Computer has allocated for the returned INQUIRY data.

DESCRIPTION

Configurations reported by devices.

RT FIELD	DESCRIPTION	SFN USAGE
00b	Indicates that the drive return the Feature Header and all Feature Descriptors supported by the drive whether or not they are currently active.	The first Feature Descriptor returned have a feature number greater than or equal to the SFN.
01b	Indicates that the Feature Header and only those Feature Descriptors that have their Current bit set to be returned.	
10b	Indicates that exactly one Feature Header and zero or one Feature Descriptors be returned. If the drive does not support the indicated feature, no Feature Descriptor is returned. <i>Note: This may be used to request Feature 0, which is a list of Profiles.</i>	The SFN specifies the Feature Descriptor that returned.
11b	<i>Reserved</i>	

Table 5.56: RT field definition

The GET CONFIGURATION command requests that the device respond with the configuration of the device and medium. The configuration of the device is described by feature. The maximum

³⁹RT : Requested Type

⁴⁰SFN : Starting Feature Number

number of features is 65,536; the maximum number of bytes that a device may return to describe its feature in one command is 65,534. Feature lists longer than 65,534 bytes require multiple commands.

Persistent Prevent may be used to control when changes occur. If a persistent prevent is in enabled, the configuration does not change except under host control.

5.27.1 GET CONFIGURATION response data

The Response Data is a Configuration Data list and contain a header followed by zero or more variable length Feature Descriptors.

	7	6	5	4	3	2	1	0	NOTE
	<i>Feature Header</i>								
00	(MSB)								
01	Data Length								
02									
03	(LSB)								
04	Reserved								00h
05									00h
06	(MSB) Current Profile								
07	(LSB)								
	<i>Feature Descriptor(s)</i>								
00	(MSB) Feature Code								
01	(LSB)								
02	Reserved	Version				Persistent	Current		
03	Additional Length								
04									
⋮	Feature Dependent Data								⋮

Table 5.57: GET CONFIGURATION response data format

Data Length field indicates the amount of data available given a sufficient allocation length following this field.

Feature Code field identify a feature supported by the drive.

Version field is reserved, set to 0000b. Future versions of a feature will be backward compatible; incompatible changes will be included in a different feature.

Persistent bit, when set to **zero**, indicate that this feature may change its current status. When set to **one**, indicate that this feature is always active. The drive does not set this bit to **one** if the Current bit is, or may become, **zero**.

Current bit, when set to **zero** indicates that this feature is not currently active and that the Feature Dependent Data may not be valid. When set to **one**, this feature is currently active and the Feature Dependent Data is valid.

Additional Length field indicates the number of Feature specific bytes that follow this header. This field is an integral multiple of 4.

FEATURE NUMBER	FEATURE NAME	DESCRIPTION	SUPPORT
0000h	Profile List	A list of all profiles supported by the device	Yes
0001h	Core	Mandatory behavior for all devices	Yes
0002h	Morphing	Ability to notify host about operational changes and accept host request to prevent operational changes	Yes
0003h	Removable Medium	The medium may be removed from the device	Yes
0004 - 000Fh	<i>Reserved</i>		—
0010h	Random Readable	Read ability for storage devices with random addressing	Yes
0011 - 001Ch	<i>Reserved</i>		—
001Dh	Multi-read	The drive can read all CD media types; based on OSTA Multi-read	Yes
001Eh	CD Read	The ability to read CD specific structures	Yes
001Fh	DVD Read	The ability to read DVD specific structures	DVD
0020h	Random Writable	Write support for randomly addressed writes	No
0021 - 0022h	<i>Reserved</i>		—
0023h	Formattable	Support for formatting of media	No
0024h	Defect Management	Ability of the device/media system to provide an apparently defect-free space	No
0025 - 00FFh	<i>Reserved</i>		—
0100h	Power Management	Host and device directed power management	Yes
0101h	S.M.A.R.T.	Self Monitoring Analysis and Reporting Technology (Failure prediction)	No
0102h	Embedded Changer	Single mechanism multiple disc changer	No
0103h	CD Audio analog play	Ability to play audio CDs via the device's own analog output	Yes
0104h	Microcode Upgrade	Ability for the device to accept new microcode via the interface	No
0105h	Time-out	Ability to respond to all commands within a specific time	Yes
0106h	DVD CSS	Ability to perform DVD CSS authentication and RPC	DVD
0107h	Real-Time Streaming	Ability to read and write using host requested performance parameters	Yes
0108 - FEFFh	<i>Reserved</i>		—
FF00 - FFFFh	<i>Vendor Unique</i>		No

Table 5.58: Feature List

5.27.2 Features

Features are the smallest implementable set of commands, pages and behavior.

Features are related by profiles. This diagram shows in a graphic form features that are defined in this specification. Each Feature is represented by a block in the diagram. Each Feature also shows an abbreviated list of the requirements for that Feature. In some cases, Features are dependent on other Features. This hierarchical relationship is shown in the diagram. If a Feature is placed underneath another Feature, then the underlying Feature may require some of the functionality of the overlying Feature. Items in quotes indicate a functionality that is required but not a specific command or page. Each Feature supported by the drive is described by a Feature Descriptor. Each Feature Descriptor has its own parameters. All features are a multiple of four bytes long. The format of a Feature Descriptor is shown in table 5.57 pp.99.

Feature 0000h: Profile List

The Profile List Feature is a list of all profiles supported by a device. This Feature is always current. The only change allowed in the Profile List during morphing is the setting of the **CurrentP** bits for each profile. The drive that support removable medium does not have any current profiles listed. Profile 0 is not reported in the Profile List, but may be reported in the Current Profile field of the GET CONFIGURATION header to indicate compliance to no profile.

Profiles provide a quick method for identifying the basic functionality of the drive. The drive may conform to more than one profile at a time.

	7	6	5	4	3	2	1	0	NOTE
00	(MSB) Feature Code								00h
01									(LSB) 00h
02	Reserved		Version			Persistent		Current	03h
03	Additional Length								
04									
⋮	Profile Descriptor(s)								⋮

Table 5.59: Feature 0000: Profile List

Feature Code field is set to 0000h.

Version field is reserved, set to 0000b. Future versions of a feature will be backward compatible; incompatible changes will be included in a different feature.

Persistent bit set to **one** to indicate that the reporting of the profile list is always supported.

Current bit set to **one**.

Additional Length field set to ((number of Profile Descriptors) ×4).

All profiles supported by the drive is always reported. Profile descriptors are returned in the order of preferred operation - most desirable to least desirable. *E.g. a DVD-ROM that could also read CD-ROM would list the DVD-ROM profile first and the CD-ROM profile second.*

	7	6	5	4	3	2	1	0	NOTE
00	(MSB) Profile Number								
01									(LSB)
02									CurrentP 00/01h
03	Reserved								00h

Table 5.60: Profile Descriptor

Profile Number identifies a profile to which the drive conforms.

CurrentP bit, when set to **one**, indicates that this profile is currently active. If no medium is present, no profile should be active. Multifunction devices select the most appropriate profiles(s), if any, to set as current. The most appropriate current profile is also reported in the Feature Header.

PROFILE NUMBER	PROFILE NAME	DESCRIPTION
0000 - 0001h		<i>Reserved</i>
0002h	Removable disk	Writable disk capable with removable media
0003 - 0007h		<i>Reserved</i>
0008h	CD-ROM	Read only Compact Disc capable
0009 - 000Fh		<i>Reserved</i>
0010h	DVD-ROM	Read only DVD
0011h		<i>Reserved</i>
0012h	DVD-RAM	Rewritable DVD
0013 - FFFh		<i>Reserved</i>
FFFFh		The drive does not conform to any profile

Table 5.61: Profile List

Feature 0001h: Core

This feature describes basic drive functionality. This feature is always current. All commands and functions described always function normally.

- INQUIRY command on pp.38 is supported. The INQUIRY command always complete without an error if the Command Packet is valid.
- MODE SENSE command on pp.52 is supported. PC field values of 00b, 01b, and 10b are implemented for all supported mode pages.
- MODE SELECT command on pp.42 is supported.
- GET CONFIGURATION command on pp.98 is supported. Unit Attention conditions isn't reported to the GET CONFIGURARTION command.
- TEST UNIT READY command on pp.32 is supported. TEST UNIT READY command is a legacy command used to check for the existence of media and to discover Unit Attention conditions.
- GET CONFIGURATION command on pp.98 or GET EVENT STATUS NOTIFICATION command pp.113 are used instead to determine media status. Unit Attention conditions can be prevented if the Morphing feature is present and is used.
- GET EVENT STATUS NOTIFICATION command is supported. The host should determine supported events by issuing a GET EVENT STATUS NOTIFICATION command with the Immed bit set.

	7	6	5	4	3	2	1	0	NOTE
00	(MSB) Feature Code								00h
01									(LSB)
02	Reserved	Version				Persistent	Current		03h
03	Additional Length								04h
04	(MSB)								00h
05	Physical Interface Standard								00h
06									00h
07									(LSB)
									01h

Table 5.62: Feature 0001: Core

Feature Code field is set to 0001h.

Persistent bit is set to **one**.

Current bit is set to **one**.

Additional Length field is set to 04h.

The Physical Interface Standard field is set to the current host to the drive communication path.

PHYSICAL INTERFACE STANDARD	DESCRIPTION	APPLICATION
00000000h	Unspecified	
00000001h	SCSI Family	X3T10 SCSI-3 Specifications
00000002h	ATAPI Family	X3T13 ATA/ATAPI-4 Specifications
00000003h	IEEE 1394 Family	
<i>Other</i>	<i>Reserved</i>	

Table 5.63: Physical Interface Standard

Feature 0002h: Morphing

The Morphing Feature provides a method for identifying changes in the drive behavior, and to some extent, preventing changes in the drive behavior without host involvement. The Feature includes a mechanism for notifying the host about events that have occurred and requests for operational changes, a mechanism for identifying the drive's current behavior, and a mechanism for allowing the drive to change its behavior.

Generation of Event Notification Class 1 events is supported.

- PREVENT/ALLOW command and the Persistent Prevent bit is supported. when a persistent prevent is in place, the drive does not allow, to the limit of its design, non-host events to change the operational behavior of the device. Devices with a mechanical eject may not be able to prevent ejecting the media. When a persistent prevent is in place, events are reported to the host via the `Get Event/Status Notification` command instead of causing action within the drive.
- SEND EVENT command is supported for any Notification Event Class 1 events that the device may generate. This command is used to tell the drive to perform an action that was previously requested by the drive via a Class 1 event notification. The host, after receiving a Class 1 notification, prepares for a possible the drive change by notifying its drivers and flushing buffers as needed. After the host is prepared for a possible device change, it sends the Class 1 event descriptor back to the drive for processing.

Feature Code field is set to 0002h.

Persistent bit is set to **one**.

Current bit is set to **one**.

Additional Length field is set to 04h.

Async bit, when set to **zero**, indicates that the drive supports only the polling implementation of `GET EVENT STATUS NOTIFICATION`.

	7	6	5	4	3	2	1	0	NOTE
00	(MSB) Feature Code								00h
01									(LSB)
02	Reserved		Version			Persistent	Current		03h
03	Additional Length								04h
04									Async
05									00h
06	Reserved								00h
07									00h

Table 5.64: Feature 0002: Morphing

Feature 0003h: Removable Medium

This feature indicates that the device has removable media. Media is considered removable if it can be removed from the loaded position. The Feature Descriptor contains information about the drive and the loading of media. In particular, the Lock bit indicates the ability of the device to honor at least one aspect of Persistent Prevent.

The drive generates an event(s) for media changes. There are two possible event classes that may be generated, either the Media Status Class or the Operational Event Class.

- **START/STOP UNIT** command is supported. The **Immed**, **Start** bits is supported. The **LoEj** bit is supported if the **Eject** bit in the Removable Medium Feature descriptor is set to **one**. A Power Condition value of 0000b is supported.
- **MECHANISM STATUS** command is supported.

	7	6	5	4	3	2	1	0	NOTE
00	(MSB) Feature Code								00h
01									(LSB)
02	Reserved		Version			Persistent	Current		03h
03	Additional Length								04h
04	Loading Mechanism Type			Eject		PvnJmpr		Lock	
05									00h
06	Reserved								00h
07									00h

Table 5.65: Feature 0003: Removable Medium

Feature Code field is set to 0003h.

Persistent bit is set to **one**.

Current bit is set to **one**.

Additional Length field is set to 04h.

Loading Mechanism Type field is set according to

LOADING MECHANISM TYPE	DESCRIPTION
000b	Caddy/Slot type loading mechanism
001b	Tray type loading mechanism
010b	Pop-up type loading mechanism
011b	<i>Reserved</i>
100b	Embedded changer with individually changer discs
101b	Embedded changer using a cartridge mechanism
110 - 111b	<i>Reserved</i>

Eject bit, when set to **zero**, indicates that the device cannot eject the medium or cartridge via the normal START/STOP command with the LoEj bit set. When set to **one**, indicates that the device can eject the medium.

PvnJmpr bit set to **zero**. The DVD-ROM drive does not have a Prevent Jumper available to indicate that the DVD-ROM drive behaves as described for a jumper being present.

Lock bit, when set to **one**, indicates that the Prevent/Allow command is capable of actually locking the media into the drive.

Feature 0010h: Random Readable

The Random Readable feature is for basic sector reading ability found on most storage class devices for which data are recorded in independently addressable logical blocks which are readable in any order. The number of blocks on the medium cannot be determined via commands in this Feature. This feature is current only if randomly readable media is present.

- READ(10) command and it's FUA bit is supported for recorded sector. The operation of the read command is modified by the Read/Write Error Recovery page settings.
- READ C/DVD CAPACITY command is supported. The Block Size is reported in the Feature Descriptor.

The Blocking field reported in the Feature Descriptor is for performance optimization only. Reads of any sector or sector count are allowed

If the PP bit in the Feature Descriptor is set, the TB, RC, PER, DTE, and DCR bits of the Read/Write Error Recovery page is supported. An Error Recovery Parameter field of 00h in the Read/Write Error Recovery page is supported. This page and changeable fields mask do not change due to medium removal or changes. The host shall be able to change changeable values whether or not media is loaded.

Feature Code field is set to 0010h.

Persistent bit is set to **zero**, indicates that the medium is removable.

Current bit is set to **zero**, indicates that random readable media is not present.

Additional Length field is set to 08h.

Logical Block Size is set to the number of bytes per logical block.

Blocking field indicates the number of logical blocks per device readable unit. The Blocking field is used by the host only for performance optimization.

Note: If installed CD media is returned 01h and DVD media is 10h, cause by ECC unit size. Otherwise no-media installed then returned 00h

PP⁴¹ bit is **one** indicated the Read/Write Error Recovery page is present.

⁴¹PP : Page Present

	7	6	5	4	3	2	1	0	NOTE
00	(MSB) Feature Code								00h
01									(LSB) 10h
02	Reserved		Version			Persistent	Current		00/01h
03	Additional Length								08h
04	(MSB)								00h
05	Logical Block Size								00h
06									08h
07									(LSB) 00h
08	(MSB) Blocking								00h
09									(LSB)
10									PP 01h
11	Reserved								00h

Table 5.66: Feature 0010: Random Readable

Feature 001Dh: Multi-read

This feature identifies a DVD-ROM drive that can read all CD media types. The DVD-ROM drive conform to the OSTA Multi-Read specification 1.00, with the exception of CD Play capability (the CD Audio feature is not required). Reading of CD Audio data via the **READ CD** command is supported.

- **READ DISC INFORMATION** command is supported. The DVD-ROM drive that does not have logical Tracks/RZones or logical Sessions identifies the media as having one session and one Track/RZone, numbered as Track/RZone 1. Fields that do not apply to the loaded media is marked as invalid or set to **zero**, as appropriate.
- **READ TRACK/RZONE INFORMATION** command is supported. The DVD-ROM drive that does not have logical Tracks/RZones report information as if the medium contains one Track/RZone encompassing all logical blocks on the medium.

	7	6	5	4	3	2	1	0	NOTE
00	(MSB) Feature Code								00h
01									(LSB) 1Dh
02	Reserved		Version			Persistent	Current		03h
03	Additional Length								00h

Table 5.67: Feature 001D: Multi-read

Feature Code field is set to 001Dh.

Persistent bit is set to **one**.

Current bit is set to **one**.

Additional Length field is set to 00h.

Feature 001Eh: CD Read

This feature indicates that the device is capable of reading CD Media, e.g. CD-ROM, CD-R and CD-RW, with logical formats including fixed and variable packets. Reading of digital audio via the **Read CD** command is supported. The reading of Audio Data is aligned such that contiguous **Read CD** commands return contiguous information, even if buffer overruns or underruns occur.

This feature indicates support for reading structures specific to CD. This feature is current only if CD specific structures are available for reading.

- READ TOC command with format codes of 0000b, 0001b, and 0010b are supported.
- READ CD and READ CD MSF commands are supported.

	7	6	5	4	3	2	1	0	NOTE
00	(MSB) Feature Code								00h
01									(LSB) 1Eh
02	Reserved		Version			Persistent	Current		00/01h
03	Additional Length								00h

Table 5.68: Feature 001E: CD Read

Feature Code field is set to 001Eh.

Persistent bit is set to **zero**, indicate the medium is removable.

Current bit is set to **zero**, indicate CD media is not present.

Additional Length field is set to 00h.

Feature 001Fh: DVD Read

This feature identifies the drive that can read DVD specific information from the media.

This feature indicates support for reading DVD specific structures. This feature is current only if DVD specific structures are available for reading.

- READ DVD STRUCTURE command, Format Codes of 00h, 01h, 03h, and 04h are supported.
- READ(10) and READ(12) commands are supported.
- READ TOC/PMA/ATIP command is supported, along with fabrication of data for DVD Media as specified in the command description.

	7	6	5	4	3	2	1	0	NOTE
00	(MSB) Feature Code								00h
01									(LSB) 1Fh
02	Reserved		Version			Persistent	Current		00/01h
03	Additional Length								00h

Table 5.69: Feature 001F: DVD Read

Feature Code field is set to 001Fh.

Persistent bit is set to **zero**, indicate the medium is removable.

Current bit is set to **zero**, indicate DVD media is not present.

Additional Length field is set to 00h.

Feature 0100h: Power Management

This feature identifies the drive that can perform host managed and host directed power management.

- Power Conditions field of the **START/STOP UNIT** command on pp.70 is supported.
- Power Condition page on pp.61 is supported.
- Power Event class of the **GET EVENT STATUS NOTIFICATION** Command on pp.113 is supported.

	7	6	5	4	3	2	1	0	NOTE
00	(MSB) Feature Code								01h
01									(LSB) 00h
02	Reserved		Version			Persistent		Current	03h
03	Additional Length								00h

Table 5.70: Feature 0100: Power Management

Feature Code field is set to 0100h.

Persistent bit is set to **one**.

Current bit is set to **one**.

Additional Length field is set to 00h.

Feature 0103h: CD Audio analog play

This Feature identifies the DVD-ROM drive that have an analog audio output port and that can play media that contain CD-DA tracks. If this feature is current, the CD Read Feature is also current.

To allow for the legacy method for the Host Computer to determine if audio operations are supported, The DVD-ROM drive respond to a **PLAY AUDIO** command which has a transfer length of zero, with **GOOD** status, regardless of whether or not this feature is current.

- **PLAY AUDIO(10)**, and **PLAY AUDIO MSF** commands is supported.
- **PAUSE/RESUME** command is supported.
- **STOP PLAY/SCAN** command is supported.
- **SCAN** command is implemented, dependent on the bit in the Feature descriptor.
- **SEEK** command is supported.
- **SEEK** command halt the playing of audio and set the current position to the LBA specified in the command. This current position may be used by a future **PLAY AUDIO** or **PLAY AUDIO MSF** command.
- **READ SUB-CHANNEL** command is supported.
- CD Audio Control page is implemented. This page isn't affected by the insertion or removal of CD Audio media.

Feature Code field is set to 0103h.

Persistent bit is set to **zero**, indicate the medium is removable.

	7	6	5	4	3	2	1	0	NOTE
00	(MSB) Feature Code								01h
01									(LSB) 03h
02	Reserved		Version			Persistent	Current		00/01h
03	Additional Length								04h
04						Scan	SCM	SV	
05	Reserved								00h
06	(MSB) Number of Volume Levels								00h
07									(LSB) 10h

Table 5.71: Feature 0103: CD Audio analog play

Current bit is set to **zero**, indicate Audio CD media is not present.

Additional Length field is set to 04h.

Scan bit, when set to **one**, indicate that the SCAN command is supported.

SCM⁴² bit, when set to **zero**, indicate that all audio channels are muted simultaneously. When set to **one**, indicate that each audio channel can be independently muted.

SV⁴³ bit, when set to **zero**, indicate that all audio channels will have the same volume level. When set to **one**, indicate that audio channel volume may be set independently.

Number of Volume Levels indicate the number of discrete volume levels supported by the drive.

Feature 0105h: Time-out

This feature identifies the drive that can always respond to commands within a set time period. If a command cannot complete normally within the allotted time, it completes with an error.

The C/DVD Time-out & Protect Page is implemented. See “5.13.8 C/DVD Time-out & Protect Page” on pp.63.

Commands that cannot complete normal execution within their specified time limit complete within the specified time limit with a CHECK CONDITION status, UNIT ATTENTION, INSUFFICIENT TIME FOR OPERATION.

	7	6	5	4	3	2	1	0	NOTE
00	(MSB) Feature Code								01h
01									(LSB) 05h
02	Reserved		Version			Persistent	Current		03h
03	Additional Length								00h

Table 5.72: Feature 0105: Time-out

Feature Code field is set to 0105h.

Persistent bit is set to **one**.

Current bit is set to **one**.

Additional Length field is set to 00h.

⁴²SCM : Separate Channel Mute

⁴³SV : Separate Volume

Feature 0106h: DVD CSS

This feature identifies the DVD-ROM drive that can perform DVD CSS authentication and key management.

This Feature identifies the drive that supports DVD CSS for DVD-Video. The DVD-ROM drive maintain the integrity of the keys by only using DVD CSS procedures. This Feature is current only if a DVD CSS protected DVD-Video medium is loaded.

- REPORT KEY command on pp.138 is supported.
- SEND KEY command on pp.134 is supported.
- READ DVD STRUCTURE Command, Format Code of 02h (pp.151) is supported.

	7	6	5	4	3	2	1	0	NOTE
00	(MSB) Feature Code								01h
01								(LSB)	06h
02	Reserved		Version			Persistent	Current		00/01h
03	Additional Length								04h
04									00h
05	Reserved								00h
06									00h
07	CSS version								01h

Table 5.73: Feature 0106: DVD CSS

Feature Code field is set to 0106h.

Persistent bit is set to **zero**, indicate the medium is removable.

Current bit is set to **zero**, indicate DVD CSS media is not present.

Additional Length field is set to 04h.

CSS version is currently set to 01h.

Feature 0107h: Real-Time Streaming

This Feature identifies the drive that support reporting and setting of performance parameters. The host may request that the drive perform at a certain data rate. A host may request a lower rate than the drive’s maximum to identify a need for a continuous stream of data. This is desired because many applications need their average data rate to be constant, even over short periods of time. If the drive must physically slow the medium to avoid “once around” access delays, this Feature provides the host requirements to the drive without specifying how that behavior is to be achieved.

	7	6	5	4	3	2	1	0	NOTE
00	(MSB) Feature Code								01h
01								(LSB)	07h
02	Reserved		Version			Persistent	Current		
03	Additional Length								00h

Table 5.74: Feature 0107: Real-Time Streaming

- GET PERFORMANCE command on pp.146 is supported.
- SET STREAMING command on pp.155 is supported.
- SET READ AHEAD command on pp.144 is supported.

Feature Code field is set to 0107h.

Persistent bit is set to **zero**, indicate the medium is removable.

Current bit is set to **zero**, indicate medium is not present.

Additional Length field is set to 00h.

5.28 PLAY AUDIO MSF command

Audio CD medium installed only valid.

	7	6	5	4	3	2	1	0	NOTE
00	Operation Code								47h
01	LUN								00h
02	Reserved								00h
03	Starting M Field								
04	Starting S Field								
05	Starting F Field								
06	Ending M Field								
07	Ending S Field								
08	Ending F Field								
09	Reserved					Flag	Link		
10	PAD								—
11									—

COMMAND FUNCTION

Request the drive to begin an audio playback operation from the specified absolute MSF address.

< Command Type > : Optional (CD audio, Analog Play)

< M/S/F Field > : Specifies the absolute MSF address at which the audio playback operation shall begin/end.

DESCRIPTION

This command requests the DVD-ROM drive to search and start an audio playback operation from the specified absolute MSF address (Starting address) and to complete audio playback when specified MSF address (Ending address) is encountered.

Starting M Field, S Field and F Field specifies the absolute CD address (Minutes, Second and Frame) which the audio playback operation shall begin. If the starting **M**, **S**, **F** field are all set to FFh, audio playback starts from current location of the optical head. This enables to change the audio ending address without interrupting current audio playback.

Otherwise, **M** field has a value between 00h to 63h (99d), **S** Field has a value between 00h to 3Bh (59d) and **F** Field has a value between 00h to 4Ah (74d).

Ending M Field, S Field and F Field specifies the absolute CD address (Minutes, Second and Frame) which the audio playback operation shall end. If the requested starting address is not in audio track, the DVD-ROM drive terminates the command and returns CHECK CONDITION status.

Basically all audio sectors between starting and the ending MSF address is played, however the DVD-ROM drive terminates the audio playback operation when the beginning of next track (Index 0 or 1) is encountered, if SOTC bit is set to **one**. If the DVD-ROM drive encounters data track during audio playback operation, it terminates the audio playback operation.

If the starting MSF address equal to the ending MSF address, no audio playback shall occur. If the starting MSF address is less than the ending MSF address, the DVD-ROM drive terminates the command with CHECK CONDITION status.

Note: That the Host Computer is able to recognize the command completion (Audio playback completion) with a READ SUB-CHANNEL or REQUEST SENSE command.

5.29 GET EVENT STATUS NOTIFICATION command

	7	6	5	4	3	2	1	0	NOTE
00	Operation Code								4Ah
01	LUN			Reserved				Immed	01h
02	Reserved								00h
03	Reserved								00h
04	<i>Notification Class Request</i>								
	Reserved	<i>Device Busy</i>	<i>Multi Host</i>	Media Status	External Request	Power Management	Operational Change Req./Noti.	Reserved	
05	Reserved								00h
06	Reserved								00h
07	(MSB) Event List Length								
08									(LSB)
09	Reserved						Flag	Link	
10	PAD								—
11									—

COMMAND FUNCTION

< Command Type > : Mandatory (Core, Morphing)

< Notification Class Request > : Request to report event(s) from the event class list.

< Event List Length > : Maximum number of bytes that the Host Computer has allocated for returned Event data.

DESCRIPTION

The **Get Event Status Notification** command requests the logical unit event(s) status(es) as specified in the Notification Class field and provides asynchronous notification. Two modes of operation are defined here. They are polling and asynchronous modes.

In polling mode, the Host will issue **Get Event Status Notification** commands at periodic intervals with an **Immed** bit set to **one**. The DVD-ROM drive complete this command with the most recently available event status requested.

In asynchronous mode, the Host will issue a single **Get Event Status Notification** command with an **Immed** bit of **zero** requested. If the logical Unit supports Asynchronous event status notification (through tagged queuing) the model outlined here shall be used.

Toshiba DVD-ROM drive does not support Asynchronous Mode, the command fails as an illegal request.

Note: Only one class of event per Get Event Status Notification command is reported. The priority of event reporting is by event Class number. The lower the class number, the higher the class number if priority.

Note: Notification Class Request bit field of all 0's indicates that the DVD-ROM drive immediately complete this command indicating No Event, and list the supported event Buffer header. This Method is used to determine which event classes a DVD-ROM drive supports.

Host software that manages media event status, may or may not be linked to other software that manages power status. This notification field provides a way that power and media event status notification can be independently managed by the responsible software.

	7	6	5	4	3	2	1	0	NOTE
00	(MSB) Event Data Length								00h
01									02/06h
02	NEA	Reserved				Notification Class			refer to 5.76
03	Supported Event Classes (Refer to CDB byte 04 field)								1Eh

Table 5.75: Event Status Header

Event Data Length field specifies the amount of data that follows the Event Status Notification Header. The amount of data reported shall be the number of bytes data following the data length field.

FIELD	DESCRIPTION
000b	No requested Event Classes are supported
001b	Operational Change Request/Notification
010b	Power Management
011b	External Request
100b	Media Status
101b	Multi-Host <i>(Not Support)</i>
110b	Device Busy <i>(Not Support)</i>
111b	<i>Reserved</i>

Table 5.76: Notification Class Field

Notification Class field specifies the class of notification by number.

NEA : If this bit set to **one**, indicate that none of the requested notification classes are supported. When set to **zero**, indicate that at least one of the requested notification classes si supported.

NOTE: In SFF-8090v1 says; If this bit set to one, it indicates that there are no events available in the requested Notification Class(es).

Supported Event Classes field specifies the event classes that the DVD-ROM drive supports as per the Notification Class Field. If a feature is supported the corresponding bit is set to **one**.

Toshiba DVD-ROM drive report 00011110b : Operational Change Request/Notification, Power management, External Request and Media event classes are supported.

5.29.1 Operational Change/Notification

This Event notifies the Host of changes in the DVD-ROM drive behavior.

	7	6	5	4	3	2	1	0	NOTE
00	(MSB) Event Data Length								00h
01	(LSB)								06h
02	NEA	Reserved				Notification Class			01/81h
03	Supported Event Classes								1Eh
04					Operational Event				refer to 5.78
05	Persistent Prevent	Reserved				Operational Status			refer to 5.79
06	(MSB) Operational Request/Report								
07	(LSB)								

Table 5.77: Operational Change/Notification Returned Data < bit1 >

Operational Event field reports the drive requests to change state and notifications of changes in drive state. If a Persistent Prevent is in place, any action request that can be reported before performing the action is not performed by the drive, and the drive notifies the Host of the requested action. In all other cases, the drive notifies the Host of actions that change drive state.

Upon reporting operational change notification to the Host, this field is reported as 0h on subsequent Get Event Status Notification commands until a new change in operational state occurs.

CODE	EVENT	DESCRIPTION
0h	NoChg	No changes in operational state performed or requested
1h	ChgRequest	The drive requests to change operational state (morph request)
2h	ChgReport	The drive has changed operational state
3 - Fh	<i>Reserved</i>	

Table 5.78: Operational Event Format

Persistent Prevent bit reports the current state of the persistent prevent for the drive.

Operational Status field reports the drive's ability to respond to the Host.

CODE	STATUS	DESCRIPTION
0h	Available	The drive is ready for operation
1h	Temporarily busy	The drive is performing a task that will self-terminate
2h	Busy	The drive is performing operations that will take an indefinite amount of time to terminate
3 - Fh	<i>Reserved</i>	

Table 5.79: Operational Status Format

Operational Request/Report field reports the operation requested or operation that has been performed. The request usually originates from the drive's eject button.

CODE	EVENT	DESCRIPTION
0000h	NoChg	No changes in operational state performed or requested
0001h	Change	The feature list may have changed
0002h	AddChange	The feature list may have added Current Features (media changed)
0003h	Reset	The drive has been reset
0004h	F/W changed	Microcode may have changed <i>(Not Support)</i>
0005h	Inquiry change	Identification information may have changed <i>(Not Support)</i>
<i>Other</i>		<i>Reserved</i>

Table 5.80: Operational Request/Report Format

5.29.2 Power Management Status Class

	7	6	5	4	3	2	1	0	NOTE
00	(MSB) Event Data Length								00h
01									(LSB) 06h
02	NEA	Reserved				Notification Class			02/82h
03	Supported Event Classes								1Eh
04	Reserved				Power Event				refer to 5.82
05	Power Status								refer to 5.83
06	Reserved								00h
07									00h

Table 5.81: Power Management Status Class Returned Data < bit2 >

Power Event field reports the current change in the power status. This field is set to a new power event if a change in power state occurs.

Upon reporting the current power status change to the Host, this field is reported to 0h on the subsequent **Get Event Status Notification** commands until a new change in power state occurs.

If the DVD-ROM drive is commanded to go the same state as the logical unit is currently in, the next **Get Event Status Notification (Power Class)** command report a Power Change Successful event.

CODE	EVENT	DESCRIPTION
0h	NoChg	No changes in power state, or in power state transition
1h	PwrChg-Succ	The drive successfully changed to the specified power state
2h	PwrChg-Fail	The drive failed to enter the last requested state, and is still operating at the power state specified in the Power Status field.
3 - Fh		<i>Reserved</i>

Table 5.82: Power Event Format

The Power Status field is set to 3h (Standby) by any of reset function (issued from Sleep state).

CODE	STATUS	DESCRIPTION
0h		<i>Reserved</i>
1h	Active	The drive is in Active state
2h	Idle	The drive is in Idle state
3h	Standby	The drive is in Standby state
4h	Sleep	The drive is in Sleep state (<i>can't report</i>)
5 - Fh		<i>Reserved</i>

Table 5.83: Power Status Format

5.29.3 External Request Status Class

External Request Class Events notify the Host of changes in behavior due to requests from the DVD-ROM drive front panel or another Host. If a Persistent Prevent is active, the Event is a request to change rather than a notification of a change.

	7	6	5	4	3	2	1	0	NOTE
00	(MSB)	Event Data Length							00h
01								(LSB)	06h
02	NEA	Reserved				Notification Class			01/81h
03	Supported Event Classes								1Eh
04						External Request Event			refer to 5.85
05	Persistent Prevent	Reserved				External Request Status			refer to 5.86
06	(MSB)	External Request							
07								(LSB)	

Table 5.84: External Request Returned Data < bit5 >

External Request Event field reports external requests to change state and notification of changes in the DVD-ROM drive state. If a Persistent Prevent is in place for the Host, the action does not performed by the DVD-ROM drive . If a Persistent Prevent is not in place for the Host, the DVD-ROM drive notify the Host of actions that change drive state.

Upon reporting operational change notification to the Host, this field is reported as 0h on subsequent **Get Event Status Notification** commands until a new External Request occurs.

CODE	EVENT	DESCRIPTION
0h	NoChg	No changes in operational state performed or requested
1h	Logical Unit Key Down	The drive's button has been pressed (<i>Not Support</i>)
2h	Logical Unit Key Up	The drive's button has been released (<i>Not Support</i>)
3h	External Request Notification	Multi-Host events report function (<i>Not Support</i>)
4 - Fh		<i>Reserved</i>

Table 5.85: External Request Event Format

Persistent Prevent bit reports the current state of the persistent prevent for the drive. If any Host has performed a persistent reservation, this bit set to **one**.

External Request Status field reports the drive's ability to respond to the Host.

CODE	STATUS	DESCRIPTION
0h	Ready	The drive is ready for operation
1h	Other Prevent	Indicates that another Host has an active Persistent Prevent. The Persistent Prevent bit set to one .
2 - Fh		<i>Reserved</i>

Table 5.86: External Request Status Format

External Request field reports the operation requested or operation that has been performed. The request usually originates from the drive's own user interface (*i.e.* front panel buttons) or from another initiator.

CODE	EVENT	DESCRIPTION
0000h	No Request	No requests are pending
0001h	Overflow	The Request Queue has overflowed, External Request Event may be lost.
0002 - 00FFh		<i>Reserved</i>
0100 - 01FFh	ASCII Button (<i>Not Support</i>)	A front panel button was pressed or equivalent action requested by another Host. The button has an associated ASCII value. The ASCII value shall be the least significant 8 bits of the Code.
0200 - EFFFh		<i>Reserved</i>
F000 - FFFFh	Vendor Unique	Not used

Table 5.87: External Request Format

5.29.4 Media Status Class

	7	6	5	4	3	2	1	0	NOTE
00	(MSB) Event Data Length								00h
01									(LSB) 06h
02	NEA	Reserved			Notification Class				04/84h
03	Supported Event Classes								1Eh
04	Reserved			Media Event					refer to 5.89
	<i>Media Status</i>								
05	Reserved				Media Present	Door or Tray open			
06	Start Slot								00h
07	End Slot								00h

Table 5.88: Media Status Class Returned Data < bit4 >

Door or Tray Open indicates if the Tray or Door mechanism is in the open state. A bit of **one** indicates the door/tray is open .

Media Present status bit indicates if there is media present in the DVD-ROM drive . This bit is reported independently from the Door or Tray Open bit.

Start/End slot field defines the first/last slot of a multiple slot logical unit the media status notification applies to. For logical units that do not support multiple slots, this field is reserved.

CODE	EVENT	DESCRIPTION
0h	NoEvent	Media status is unchanged.
1h	Eject Request	The DVD-ROM drive has received a request from the user (usually through a mechanical switch on the DVD-ROM drive) to eject the media (when persistent prevent state can report).
2h	New Media	The DVD-ROM drive has received new media, and is ready to access it.
3h	Media Removal	The Media has been removed from the DVD-ROM drive , and the DVD-ROM drive is unable to access the media without user intervention.
4 - Fh		<i>Reserved</i>

Table 5.89: Media Event Format

The DVD-ROM drive returned Media Status Class data based on currently status. The top of the reported event priority is a New Media event, second is a Eject Request event, third is a Media Removal.

When the Toshiba DVD-ROM drive accept persistent prevent operation, and the drive was already reported the **New Media** status to Host, then when enable persistent prevent state.

5.29.5 Multi-Host Class

Toshiba DVD-ROM drive does not support this Class event.

5.29.6 Device Busy Class

Toshiba DVD-ROM drive does not support this Class event.

5.30 PAUSE/RESUME command

Audio CD medium installed only valid.

	7	6	5	4	3	2	1	0	NOTE	
00	Operation Code								4Bh	
01	LUN									00h
02									00h	
03									00h	
04									00h	
05	Reserved								00h	
06									00h	
07									00h	
08								Resume	00/01h	
09							Flag	Link		
10	PAD								—	
11									—	

COMMAND FUNCTION

Request the drive to stop (pause) or to start (resume) an audio playback operation.

< Command Type > : Optional (CD Audio, Analog Play)

<Resume> : Resume bit of **zero** requests the DVD-ROM drive to start pause during an audio playback operation. Resume bit of **one** requests the DVD-ROM drive to release pause status and resume audio playback operation.

DESCRIPTION

This command requests the DVD-ROM drive to stop (pause) the audio playback operation temporary or to release the pause status and start (resume) the audio playback operation. Resume bit set to **zero** requests the DVD-ROM drive to enter hold (pause) status with audio output muted. During this hold status, the DVD-ROM drive maintains the optical pickup head at an approximately constant position.

The DVD-ROM drive returns CHECK CONDITION status to this command with Resume bit set to **zero** when an audio playback operation is not in progress.

Resume bit set to **one** requests the DVD-ROM drive to release the pause status and start (resume) the audio playback operation.

The DVD-ROM drive releases the pause status and audio playback resumes from the audio sector following the last block played before pause status.

It is not an error to request a pause when a pause is already in effect or to request a resume when an audio playback operation is in progress.

Note: That it is also possible to release pause status by issuing another command such as PLAY AUDIO or READ command.

5.31 STOP PLAY/SCAN command

CD medium installed only valid.

	7	6	5	4	3	2	1	0	NOTE	
00	Operation Code								4Eh	
01	LUN									00h
02									00h	
03									00h	
04									00h	
05	Reserved								00h	
06									00h	
07									00h	
08									00h	
09							Flag	Link		
10	PAD								—	
11									—	

COMMAND FUNCTION

Request the drive to stop audio playback or audio scan operation.

< Command Type > : Mandatory (CD Audio, Analog Play)

DESCRIPTION

This command is used to stop current audio playback or audio scan operation. As to the transition sequence of PLAY, SCAN, PAUSED and IDLE state upon a PLAY AUDIO, AUDIO SCAN, PAUSE/RESUME and STOP PLAY/SCAN command.

5.32 READ DISC INFORMATION command

	7	6	5	4	3	2	1	0	NOTE	
00	Operation Code								51h	
01	LUN									00h
02									00h	
03									00h	
04	Reserved								00h	
05									00h	
06									00h	
07	(MSB) Allocation Length									
08									(LSB)	
09	Reserved						Flag	Link		
10	PAD								—	
11									—	

COMMAND FUNCTION

Requests the drive to transfer general information about the C/DVD medium that is mounted to the Host. The parameters returned are specific to the media that is currently installed in the drive.

< Command Type > : Mandatory (SFF-8090)

DESCRIPTION

It is not possible to completely characterize some incomplete C/DVD-R, CD-RW discs with the information from the Read TOC/PMA/ATIP Information or Read C/DVD Structure information. The Read Disc Information Command provides information about all discs: C/DVD-ROM, C/DVD-R, DVD-RAM and CD-RW, including all incomplete C/DVD-R, CD-RW discs.

The number of Disc Information Block bytes returned is limited by the Allocation Length parameter of the CDB. An Allocation Length of zero is not considered an error, command is immediately to complete. If the Allocation Length is greater than the amount of available Disc Information Data, only the available data will be transferred.

Disc Information length is the number of bytes available in the recording information area and the appended OPC table. Data Length excludes itself.

Erasable flag, when set to **one**, indicates that CD-RW medium is present. Otherwise, CD-RW medium is not present.

Status of Last Session/Border is valid only for discs with either empty or incomplete status and given by the following table.

Disc Status field indicates the status of the disc. The drive which does not have the ability to write for the inserted medium will return "Complete" (10b) status.

Number of First track/RZone on disc is:

If DVD medium, this field is set to 01h.

1. If Disc Status is set to 00b (Empty Disc), the Number of First track field is 01h.
2. If there is no PMA for track information and the first track is incomplete track, the track Number of First track is equal to 01h.
3. If there are PMA for track information and there is no Complete Session, the track Number of First track is from PMA.

	7	6	5	4	3	2	1	0	NOTE	
00	(MSB) Disc Information length									
01									(LSB)	
<i>Information Block</i>										
02	Reserved			Erasable	Status of Last Session/Border		Disc Status			
03	Number of First track/RZone on Disc									
04	Number of Sessions/Borders(LSB)									
05	First track Number in Last Session/Border(LSB)									
06	Last track Number in Last Session/Border(LSB)									
07	DID_V [†]	DBC_V [†]	URU	Reserved						
08	Disc Type [†]									/00h
09	Number of Sessions/Borders(MSB)									
10	First track Number in Last Session/Border(MSB)									
11	Last track Number in Last Session/Border(MSB)									
12	(MSB)									/00h
13	Disc Identification [†]									/00h
14										/00h
15										(LSB) /00h
16	(MSB)									/00h
17	Lead-in Start Time for Last Session [†]									/00h
18	MSF									/00h
19										(LSB) /00h
20	(MSB)									/00h
21	Last Possible Start Time for Start of Lead-out [†]									/00h
22	MSF									/00h
23										(LSB) /00h
24	(MSB)									/00h
⋮	Disc Bar Code [†]									⋮
31										(LSB) /00h
32	Reserved									00h
33	Number of OPC Table Entries									
⋮	Entries OPC Table(s)									⋮

Key: [†] : invalid field for DVD media.

Table 5.90: Disc Information Returned

STATUS OF LAST SESSION	DESCRIPTION
00b	Empty Session <i>Reserved for ROM device</i>
01b	Incomplete session <i>Reserved for ROM device</i>
10b	<i>Reserved</i>
11b	Complete Session (Only possible when Disc Status is Complete)

Table 5.91: Status of Last Session

4. Otherwise, this is the track number for the first TOC entry for track.

Number of Sessions/Borders on the disc refers to all complete sessions/Borders plus any incomplete or empty sessions/Borders. A Blank Disc will always have a session/Border count

DISC STATUS	DESCRIPTION
00b	Empty Disc <i>Reserved for ROM device</i>
01b	Incomplete Disc (Appendable) <i>Reserved for ROM device</i>
10b	Complete Disc (Not Appendable. ROM, completed or write protected medium)
11b	Others (non-write protected DVD-RAM disc)

Table 5.92: Disc Status

equal to 01h.

First Track/RZone Number in Last Session/Border and **Last Track/RZone Number in Last Session/Border**. In order that tracks/RZones in a last session/Border which is open may be scanned for **Read track Information** Command, both the First track/RZone Number in Last Session/Border and the Last track/RZone Number in Last Session/Border are identified. This is inclusive of the invisible track/RZone.

DID_V⁴⁴ flag specifies the validity of the Disc Identification field. If it is set to **one**, then the Disc Identification field is valid. Otherwise, it is invalid.

DBC_V⁴⁵ flag specifies the validity of the Disc Bar Code field. If it is set to **one**, then the Disc Bar Code field is valid. Otherwise, it is invalid.

URU⁴⁶ bit, when set to **one**, indicates that the mounted DVD-R, CD-R/RW disc is defined for unrestricted use. When the URU bit is set to **zero**, the mounted DVD-R, CD-R/RW disc is defined for restricted use. To record data to the mounted disc the appropriate Host Application code shall set through the Write Parameters Page. A Host Application Code of zero may be used to indicate a restricted use disc-general purpose.

Disc Type (for CD) specifies the type of the data on whole disc. A disc has only one disc type. The disc type is recorded in the A0/PSEC field in the TOC of the session in which there is at least one data track, or is recorded together with disc ID in PMA. In the case of a session that contains no data tracks (only audio), A0/PSEC field in the TOC of the session is always 00h regardless of actual disc type. For CD disc, the Disc type is determined from the following sequence.

1. DISC ID (Disc Type) as written in PMA.
2. From the first Complete Session that includes at least one data track.
3. From the first session of a Complete Disc (not appendable).
4. The Disc type is NOT decided, the Disc Type field of Disc Information data contain FFh.

Disc Identification number recorded in the PMA is returned. The Toshiba DVD-ROM drive does not read PMA area, then this field is filled with 00h.

Lead-in Start Time for Last Session field valid only for CD medium. Otherwise, this field set to 00h. If the Disc Status is Complete, the Lead-in Start Time field is filled with FFh.

Last Possible Start Time of Lead-out field is valid for CD medium. Otherwise, this field set to 00h. If the disc is a Complete disc, the Last Possible Start Time of Lead-out field is filled with FFh.

Disc Bar Code . The Toshiba DVD-ROM drive does not have ability to read Disc Bar Code, then this field is filled with 00h.

⁴⁴DID_V: Disc Identification Valid

⁴⁵DBC_V: Disc Bar Code Valid

⁴⁶URU: Unrestricted Use Disc

DISC TYPE CODE	DISC TYPE
00h	CD-DA or CD-ROM Disc
10h	CD-I Disc
20h	CD-ROM XA Disc
FFh	Undefined
All other value	<i>Reserved</i>

Table 5.93: Disc Type Code

Number of OPC Table Entries . An OPC⁴⁷ Table is attached only if the values are known for the mounted disc. Since OPC values are likely to be different for different recording speeds, each table entry is associated with a recording speed. The Number of OPC Table Entries will always be **zero** for C/DVD-ROM, RAM discs and for CD-R/RW discs for which OPC have not yet been determined. For DVD-R, using of OPC table entries is vendor-specific.

Then the Toshiba DVD-ROM drive is set this field to **00h**, and none of return OPC table entry.

⁴⁷OPC: Optimum Power Calibration

5.33 READ TRACK/RZONE INFORMATION command

	7	6	5	4	3	2	1	0	NOTE
00	Operation Code								52h
01	LUN			Reserved			Address/Number Type		
02	(MSB)								
03	Address / Number								
04									
05									(LSB)
06	Reserved								00h
07	(MSB)								
08	Allocation Length								
09	Reserved						Flag	Link	
10	PAD								—
11									—

COMMAND FUNCTION

Request the drive to provides information about a track, regardless of it's status.

< Command Type > : Mandatory (SFF-8090)

DESCRIPTION

Address/Number Type field is used to specify the contents of bytes 2 through 5 of the CDB.

Address/Number field definition is follow.

ADDRESS/NUMBER TYPE VALUE	ADDRESS/NUMBER FIELD	DESCRIPTION
00b	Logical Block Address	T_{LBA} , where T_{LBA} is the number of the Track/RZone which contains the block associated with Logical Block Address.
01b	00000000h	T_{TOC} , where T_{TOC} is the Lead-in area of the disc. <i>(Not Support)</i>
01b	Valid Track/RZone Number	T_{CDB}
01b	FFFFFFFFh	T_{INV} , where T_{INV} is the Track number of the invisible or incomplete Track. <i>(Not Support)</i>
10b	Border Number	R_{Border} , where R_{Border} is the number of the first RZone which is in the Border Number.
11b		<i>Reserved</i>

Note: The Address/Number Type 2 is easy way to recognize UDF-Bridge file system that specified by DVD-ROM Book Part2.

Table 5.94: Address/Number Field definition

The number of Track/RZone Information Block bytes returned is limited by the Allocation Length parameter of the CDB. An Allocation Length of 0000h is not an error. The invalid field for corresponded media will return zero.

The format and content of the Track/RZone Information Block is shown Table 5.95.

Track/RZone Information Length field specifies the length, in bytes, of the requested data to be transferred given a sufficient Allocation Length. The Track/RZone information length value does

	7	6	5	4	3	2	1	0	NOTE	
00	(MSB) Track/RZone Information Length								00h	
01	(LSB)								22h	
<i>Information Block</i>										
02	Track/RZone Number (LSB)									
03	Session/Border Number (LSB)									
04	Reserved								00h	
05			Damage	Copy [‡]	Track Mode [‡]					
06	RT	Blank	Packet/Inc	FP [‡]	Data Mode [‡]					
07	Reserved						LRA_V	NWA_V	00/01h	
08	(MSB) Track/RZone Start Address									
09										
10										
11	(LSB)									
12	(MSB) Next Writable Address								00h	
13									00h	
14									00h	
15	(LSB)								00h	
16	(MSB) Free Blocks								00h	
17									00h	
18									00h	
19	(LSB)								00h	
20	(MSB) Fixed Packet Size /									
21	Blocking Factor									
22										
23	(LSB)									
24	(MSB) Track/RZone Size									
25										
26										
27	(LSB)									
28	(MSB) Last Recorded Address									
29										
30										
31	(LSB)									
32	Track/RZone Number (MSB)									
33	Session/Border Number (MSB)									
34	Reserved								00h	
35									00h	

Key: ‡ : invalid field for DVD-R media.

Table 5.95: Track/RZone Information Returned

not include the Track/RZone information length field itself. If the Allocation Length specified is less than the Track/RZone information length, the response will be truncated at the Allocation Length specified. This truncation does not cause a **Check Condition** status to be presented. The Track/RZone information length is not modified when the allocation length is insufficient to return all of the response data available.

Track/RZone Number is the Track/RZone number for all of the information in this structure.

Session/Border Number , Session Number is the number on CD media, Border Number on DVD media, or **one** for media not containing Sessions or Borders, that contains this Track/RZone.

Copy bit indicates that this track is a second or higher generation copy. (CD) For all other media, this bit will be set to **zero**.

Damage bit, when set to **one**, and the *NWA_V* is set to **zero**, the Track/RZone is considered “not closed due to an incomplete write.”

Track Mode field is the control nibble as defined for mode 1 *Q* sub-channel for this track. Except CD media, this field will be set to 0100b.

RT bit, when set to **zero**, indicates that the Track/RZone is not reserved, otherwise the Track/RZone is reserved. For CD, RT indicates that a PMA entry indicating the track’s start and end address exists.

Blank bit, when set to **one**, indicates that the Track/RZone contains no written data and Last Recorded Address field is invalid. For CD, tracks with the Track Descriptor Block recorded is not considered blank.

Packet/Inc bit, when set to **one**, indicates that this Track/RZone is to be written only with incremental recording (DVD) or packets (CD). For CD, the Packet/Inc bit is valid only when the RT bit is set to **one** or the track indicated is the incomplete track.

FP ⁴⁸ bit is valid only when the Packet/Inc bit is set to **one**. When the Packet/Inc bit is set to **one** and FP bit is also set to **one**, then the track is to be written only with fixed packets. When the Packet/Inc bit is set to **one** and FP bit set to **zero**, then the track is to be written only with variable packets.

Data Mode (CD) is defined follow.

VALUE	DESCRIPTION
1h	Mode 1 (ISO/IEC 10149)
2h	Mode 2 (ISO/IEC 10149 or CD-ROM XA)
Fh	Data Block Type unknown (no track descriptor block)
<i>Other</i>	<i>Reserved</i>

LRA_V ⁴⁹ bit validates the last recorded address. If *LRA_V* is **zero**, then the Last Recorded Address field is not valid. Otherwise, the Last Recorded Address field is valid.

NWA_V ⁵⁰ bit validates the next writable address. If *NWA_V* is **zero**, then the Next Writable Address field is not valid. Otherwise, the Next Writable Address field is valid.

Track/RZone Start Address is the starting address for the specified Track/RZone.

Next Writable Address , if valid, is the LBA of the next writable user block in the Track/RZone specified by the LBA/Track/RZone Number field in CDB.

Free Blocks field represents the maximum number of user data blocks available for recording in the Track/RZone. For CD, this field is computed as follows: First, the Available Track Space (ATS) is computed. For the invisible track, $ATS = (StartTimeofLastPossibleLeadout) - NWA + 5$. For reserved track, $ATS = (PMAStopTime) - NWA + 5$. If the track is reserved for, or written with, fixed packets,

$$FreeBlocks = IP \left(\frac{ATS}{PacketSize + 7} \right) \bullet PacketSize. \text{ Otherwise, } FreeBlocks = ATS - 7$$

Note: The StartTimeofLastPossibleLead-out is the last possible location of the link block at the start of the lead-out. If a disc is fully recorded, the PMA entry for the last track will be equal to the StartTimeofLastPossibleLead-out.

⁴⁸FP: Fixed Packet

⁴⁹LRA_V : Last Recorded Address Valid

⁵⁰NWA_V : Next Writable Address Valid

Addressing within fixed packet written tracks is translated by the drive for reading and writing. The NWA also reflect this translation:

$$NWA_{Method2} = NWA_{Method1} - 7 \bullet IP \left(\frac{NWA_{Method1} - TrackStartAddress}{PacketSize + 7} \right)$$

Method 1 is the physical address. Method 2 is used on fixed packet written tracks to hide the link areas from the initiator. The *TrackStartAddress* is always a physical address, even if prior tracks are recorded with Method 2. *IP()* is the integer part of the value.

Fixed Packet Size/Blocking Factor field is valid only when the Packet/Inc and the FP bits are both set to **one** (CD).

If FP bit is set to **zero**, the Fixed Packet Size/Blocking Factor field specifies the number of sectors that is actual disc access unit (DVD). In case of DVD, this field is 16. FP bit **one** is undefined yet.

If the disc is stamped, then Damage, Blank, RT and NWA_V bits are **zero**.

Track/RZone size reports the length in blocks of the specified Track/RZone. For CD, The track size is computed as follow: First, compute the Complete Track Size (CTS). For an incomplete track, $CTS = (StartTimeofLastPossibleLeadout) - PMATrackStart + 5$. For a reserved track, $CTS = (PMAStopTime) - PMAStartTime + 5$. If the track is reserved for, or written with, fixed packets.

$$TrackSize = IP \left(\frac{CTS}{PacketSize + 7} \right) \bullet PacketSize. \text{ Otherwise, } TrackSize = CTS - 7$$

Last Recorded Address is the address of finally written sector of the specified RZone.

Track Size number may not be exact for the tracks that do not have a PMA entry. This track size of tracks that do not have PMA entries is calculated as follows:

$$TrackSizeofTrack_n = (StartofTrack_{n+1}) - (StartofTrack_n)$$

$n + 1$ is the Lead Out if n is the last track recorded in the TOC. The Track Size from this calculation may include blocks from the following track and these blocks may not be readable.

5.34 MODE SELECT(10) command

	7	6	5	4	3	2	1	0	NOTE
00	Operation Code								55h
01	LUN			PF				SP	10h(/00h)
02									00h
03	Reserved								00h
04									00h
05									00h
06									00h
07	(MSB)	Parameter List Length							
08								(LSB)	
09	Reserved						Flag	Link	
10	PAD								—
11									—

COMMAND FUNCTION

Provides a means for the Host Computer to specify following parameters.

< Command Type > : Mandatory (Core)

< Parameter List Length > : This field specifies the length in bytes of the MODE SELECT parameter list that is transferred from the Host Computer.

< PF > : Page Field (if requested or not)

< SP > : Save Pages function is not supported (should be set to **zero**).

DESCRIPTION

The parameter list length field specifies the length in bytes of the MODE SELECT parameter list that is transferred. A parameter list length of **zero** indicates that no data is transferred and the command terminates immediately. (Any parameter is not changed.)

The MODE SELECT parameter list (Table 5.96) contains eight bytes mode parameter header, followed by **zero** or more pages.

	7	6	5	4	3	2	1	0	NOTE
00	Reserved								00h
01									00h
02	Medium Type								00h
03									00h
04	Reserved								00h
05									00h
06	Block Description Length								00h
07									00/08h
	<i>Block Descriptor(s)</i>								
	<i>Page Descriptor(s)</i>								

Table 5.96: Mode Select(10) parameter list

More detail describe on Section 5.10 MODE SELECT(6) command (Page 42).

5.35 MODE SENSE(10) command

	7	6	5	4	3	2	1	0	NOTE
00	Operation Code								5Ah
01	LUN		Reserved	DBD	Reserved				00h/08h
02	PC		Page Code						
03									00h
04	Reserved								00h
05									00h
06									00h
07	(MSB) Allocation Length								
08									(LSB)
09	Reserved						Flag	Link	
10	PAD								—
11									—

COMMAND FUNCTION

Reports the current, changeable and default value of page parameters. This command is a complementary command to the MODE SELECT command.

< Command Type > : Mandatory (Core)

< DBD > : Disable block Descriptor bit of **one** specifies that the DVD-ROM drive shall not return block descriptor field in the returned MODE SENSE data

< PC > : Page Control field defines the type of parameters to be returned

< Page Code > : Specifies which page or pages to return

< Allocation Length > : Maximum number of bytes that the Host Computer has allocated for returned MODE SENSE data

DESCRIPTION

This command provides a means for the DVD-ROM drive to report current (specified with a MODE SELECT command), changeable and default value of page parameters and also block length.

	7	6	5	4	3	2	1	0	NOTE
00	(MSB) Mode Data Length								
01									(LSB)
02	Medium Type								
03									00h
04	Reserved								00h
05									00h
06	Block Description Length								00h
07									00/08h
	<i>Block Descriptor(s)</i>								
	<i>Page Descriptor(s)</i>								

Table 5.97: Mode Sense(10) Parameter List

More detail describe on Section 5.13 MODE SENSE(6) command (Page 52).

5.36 SEND EVENT command

	7	6	5	4	3	2	1	0	NOTE
00	Operation Code								A2h
01	LUN							Immed	01h
02									00h
03									00h
04	Reserved								00h
05									00h
06									00h
07									00h
08	(MSB)	Parameter List Length							00h
09								(LSB)	08h
10	Reserved								00h
11							Flag	Link	

COMMAND FUNCTION

Requests the DVD-ROM drive to process an event for the Host. The event should be one that the host had received from an earlier **GET EVENT STATUS NOTIFICATION** command but not handled by the Host.

< Command Type > : Mandatory (Morphing)

DESCRIPTION

If a DVD-ROM drive has received a persistent prevent, it will report events via the **GET EVENT STATUS NOTIFICATION** command instead of processing them directly.

The Media Status Class Events reported to the Host shall not be sent back to the DVD-ROM drive using the **SEND EVENT** command. Only events of class Operation Change Request/Notification shall be sent via the **SEND EVENT** command.

An **Immed** bit of **one** indicates that status is returned as soon as the Command Packet has been validated. The actual operation specified by the Event Parameter is processed after the status has been reported to the Host. The **Immed** bit shall be set to **one**.

The Parameter List Length field specifies the length in bytes of the Event parameter list that shall be transferred from the Host Computer to the DVD-ROM drive after the Command Packet is transferred. A parameter list length of **zero** indicates that no data to be transferred. This condition isn't considered as an error.

The DVD-ROM drive shall terminate the command with **CHECK CONDITION** status if the Event parameter list length results in the truncation of Event parameter data. The sense key is set to **ILLEGAL REQUEST**, and the additional sense code is set to **PARAMETER LIST LENGTH ERROR**.

The DVD-ROM drive shall terminate the command with **CHECK CONDITION** status, set the sense key to **ILLEGAL REQUEST**, set the additional sense code to **INVALID FIELD IN PARAMETER LIST**, and shall not take any action directed by the event specified for the following conditions:

1. If the Host Computer sets any unreserved field in the Event parameter header to an unsupported value.
2. If an Host Computer sends an Event parameter list with a Event Data Length not equal to the length returned by the **GET EVENT STATUS NOTIFICATION** command for the specified event class.
3. If the Host Computer sends an invalid value for any Event parameter.

	7	6	5	4	3	2	1	0	NOTE
00	(MSB) Event Parameter Length								00h
01									(LSB) 06h
02	Notification Class								03h
03	Reserved								00h

Table 5.98: Event Parameter Header

Event Parameter Length field specifies the number of bytes that follow the Event Parameter Length field.

Notification Class field specifies the class of Event being sent to the DVD-ROM drive . This field contain 011b (External Request Class Events *pp.117*).

	7	6	5	4	3	2	1	0	NOTE
00					External Request Event				00h
01	Persistent Prevent	Reserved			External Request Status				00h
02	(MSB) External Request Code								00h
03									(LSB) 00h

Table 5.99: External Request Parameter Data

External Request Event field indicates the type of operation to be performed.
Only 00h: NoChg request is supported.

Persistent Prevent bit is reserved.

External Request Status field is reserved.

External Request Code field is reserved. (refer to Table 5.87 *pp.118*).

5.37 SEND KEY command

DVD medium installed only valid.

	7	6	5	4	3	2	1	0	NOTE	
00	Operation Code								A3h	
01	LUN									00h
02									00h	
03									00h	
04	Reserved								00h	
05									00h	
06									00h	
07	Key Class								00h	
08	(MSB) Parameter List Length									
09									(LSB)	
10	AGID			KEY Format						
11	Reserved						Flag	Link		

COMMAND FUNCTION

Provide a protected data necessary for authentication and for generating Bus-Key to the drive.

< Command Type > : Mandatory for Copy Protected Disc to play. (DVD CSS)

< KEY Format > : Type of information is requested by the host.

< AGID > : Described in the REPORT KEY command.

DESCRIPTION

This command, in conjunction with REPORT KEY command, is intended to perform authentication for DVD-ROM drive which conform to DVD Copy Protection scheme and to generate a Bus-Key as the result of authentication.

The **Key Class** field identify the type of authentication conversation according to Table 5.100

KEY CLASS	AUTHENTICATION TYPE
00h	DVD CSS
01h	Rewritable Security Services-A
<i>Other</i>	<i>Reserved</i>

Table 5.100: Key Class Definitions

KEY FORMAT	SENT DATA	DESCRIPTION
000001b	Challenge-Key	Accepts a Challenge Key
000011b	KEY2	Accepts a KEY2
000110b	RPC Structure	Set Region
111111b	None	Invalidate Specified AGID
All other value		<i>Reserved</i>

Table 5.101: Key Format Code definition

5.37.1 Accepts a Challenge Key (Format 000001b)

	7	6	5	4	3	2	1	0	NOTE	
00	(MSB)	SEND KEY Parameter List Length								00h
01								(LSB)	0Eh	
02		Reserved								00h
03										00h
		<i>Challenge Key</i>								
04	(MSB)									
05										
06										
07										
08		Challenge Key Value								
09										
10										
11										
12										
13										(LSB)
14		Reserved								00h
15										00h

Table 5.102: SEND KEY Parameter List (Format = 000001b)

Challenge Key is sent to the DVD-ROM drive to get corresponding KEY1 from the DVD-ROM drive to interrogate conformity with DVD Copy Protection scheme.

5.37.2 Accepts a KEY2 (Format 000011b)

	7	6	5	4	3	2	1	0	NOTE	
00	(MSB)	SEND KEY Parameter List Length								00h
01								(LSB)	0Ah	
02		Reserved								00h
03										00h
		<i>KEY2</i>								
04	(MSB)									
05										
06		KEY2 Value								
07										
08										(LSB)
09										00h
10		Reserved								00h
11										00h

Table 5.103: SEND KEY Parameter List (Format = 000011b)

The KEY2, generated external to the DVD-ROM drive, is sent to the DVD-ROM drive to determine is conformity with DVD Copy Protection scheme. The KEY2 value will be used for the second input to generate Bus-Key in the DVD-ROM drive.

When the KEY2 value send does not conform with DVD copy Protection scheme, this command is terminated with an CHECK CONDITION status. The sense key is set to ILLEGAL REQUEST and the additional sense code & qualifier set to COPY PROTECTION KEY EXCHANGE FAILURE --- AUTHENTICATION FAILURE.

5.37.3 Set Region (Format 000110b)

	7	6	5	4	3	2	1	0	NOTE	
00	(MSB)	SEND KEY Parameter List Length								00h
01								(LSB)	06h	
02			Reserved						00h	
03									00h	
			<i>RPC</i>							
04		Preferred Drive Region Code								
05									00h	
06			Reserved						00h	
07									00h	

Table 5.104: SEND KEY Parameter List (Format = 000110b)

Preferred Drive Region Code is sent to the DVD-ROM drive to make the Logical Unit regionalized. The Preferred Drive Region Code specifies a single region in which the disc can be played. Each bit represents one of eight regions. If a bit is Cleared in this field, the disc can be played in the corresponding region. If a bit is Set in this field, the disc cannot be played in the corresponding region. Exactly one bit of the Preferred Drive Region Code shall contain a **zero**.

If the Region is no longer changeable, then this command is terminated with **Region Reset Count Error**.

Region Playback Control(RPC)

There is an additional copy management capability used for Copy Protected DVD-ROM media that limits the playback of content to specific regions of the world. The capability is called **Region Playback Control(RPC)** or Regionalization.

Playback limitations by World Region

The use of Regionalization is limited to Discs that employ CSS. There are two places that contain region information, one in the drive and another for each media that contained CSS Scrambled Title(s). When the region in the drive and that of the CSS Title are different the system shall prevent the playback of that title(movie).

When a **REPORT KEY** command with Format Code of **04h (Title Key)** is received by a drive that is in the **Bus Key Established** state, and the region code of the current media is not playable in the current region set in the drive, the command is terminated with a **CHECK CONDITION**. CSS media is deemed not playable if the region of the drive is not set.

If the Region Code Mismatch error is generated, the **Authentication Success Valid Flag(ASF)** is reset to **zero**.

The drive will report the current RPC state using the **REPORT KEY** command with Format Code **08h**.

Region Code Setting

Two methods have been defined for setting the region code in the DVD logical unit. Each method has the same end result, specifying which region shall be used to determine if it is allowable to play a movie which has region code included within the information on the disc in this drive.

The drive has the following four Region State according to the Drive Region setting.

NONE state

The Drive Region has not been set and the Host Computer shall set the initial Drive Region value in the drive. The region setting counter shall be **five**. The drive respond to the **REPORT KEY** command completion and a Region Mask value of **FFh**.

SET state

The Drive Region has been set and the change of the Region is acceptable. The region setting counter shall initially be **four**. decrementing to **two**.

LAST CHANCE state

The Drive Region has been set and the changer of the Region is acceptable. In order to change the Drive Region using a command method, an inserted disc shall have a same single region with the requested Region. The region setting counter shall be **one**.

PERMANENT state

The Drive Region has been set and the change of the Region is not acceptable. The region setting counter shall be **zero**. However, the Drive Region can be re-initialized by toshiba factory(only) to become the NONE state.

Initial Setting

In the *NONE state*, the Drive Region has not been set and the Host Computer shall set the initial Drive Region value in the drive. The region setting counter shall be **five**. The drive respond to **REPORT KEY** command, **KEY FORMAT = 01000b**, with successful command completion and a Region Mask value of **FFh**.

The Host Computer shall set a preferable region, the value of which is specified in the Preferred Drive Region Code field of the **SEND KEY** command with **KEY Format = 000110b**. On execution of this command, the drive ignores the region code of the inserted medium.

After the successful execution of setting the Drive Region, the region setting counter shall be decremented to **four** and the drive enter *Set state*.

Changing of the drive region

In the *Set state*, the Drive Region has been already set and may be changed by one of the following two methods. After the successful execution of changing the Drive Region, the region setting counter is decremented. When the region setting counter shall be **one**, the drive enter into the *LAST CHANCE state*.

In the *LAST CHANCE state*, the Drive Region may be changed by one of the following two methods. In case of Command method with a Disc, the inserted disc shall have the same single region code value as the Preferred Drive Region Code specified in the **SEND KEY** command. After the successful execution of the Drive Region change, the region setting counter shall be **zero** and the drive enter into *PERMANENT state*.

In the *PERMANENT state*, user cannot change the Drive Region.

Command method for changing the drive region with CSS enabled Disc

To set the drive region, the procedure shall be executed as follow;

1. Insert a disc having the requested Region.
2. Issue a **SENDKEY** command with the **KEY Format = 000110b**. The requested Region Code value shall be specified in the Preferred Drive Region Code field.

When the drive receives the **SEND KEY** command correctly, the drive region is changed to the requested region.

If the disc does not have the same region code value with the Preferred Drive Region Code specified in the **SEND KEY** command then the command will be terminated with a **CHECK CONDITION**.

Sending Disc method for changing the drive region

The drive region may be set by inserting a special disc which contain a specific region code. This special disc does not require any command intervention.

Limits on Drive Region Changes

Any of methods defined in this specification may be used up to **five** times to change a Drive's region. If the new region is the same as the old region, the region setting process is terminated as if it had not occurred.

If an attempt, by the user, is made to change the Drive Region more than **five** times, the **SEND KEY** command will be terminate with a **CHECK CONDITION**. All region code values in the drive at the time of execution shall remain.

5.38 REPORT KEY command

DVD medium installed only valid.

	7	6	5	4	3	2	1	0	NOTE
00	Operation Code								A4h
01	LUN			Reserved					00h
02	(MSB)								
03	Reserved or Logical Block Address								
04									
05									
06									
07	Reserved								00h
08	Key Class								00h
09	(MSB) Allocation Length								
10									
11	(LSB)								
	AGID			KEY Format					
	Reserved						Flag	Link	

COMMAND FUNCTION

Request the drive to transfer TITLE-KEY data, obfuscated by a Bus-Key, to the Host Computer.

< Command Type > : Mandatory for Copy Protected Disc to play. (DVD CSS)

<AGID > : Used to control simultaneous key exchange sequence. The AGID⁵¹ specified in subsequent Key Exchange commands shall match a currently active AGID. The AGID field is reserved when the KEY Format field is 0h or 5h.

<KEY Format > : Indicates the type of information that is requested to the host.

DESCRIPTION

The REPORT KEY command requests the start of the authentication process and provides data necessary for authentication and for generating a Bus-Key for the DVD-ROM drive. This command, in conjunction with SEND KEY command, is indicated to perform authentication for the DVD-ROM drive which conform to DVD Copy Protection scheme and to generate a Bus-Key as the result of authentication.

The **Key Class** field identify the type of authentication conversation according to Table 5.100

KEY FORMAT	RETURNED DATA	DESCRIPTION
000000b	AGID	Returns an AUTHENTICATION GRANT ID
000001b	Challenge-KEY	Returns a Challenge-KEY
000010b	KEY1	Returns a KEY1
000100b	TITLE-KEY	Returns a TITLE-KEY obfuscated by a Bus-Key
000101b	ASF	Returns the current state of the Authentication Success Flag
001000b	RPC State	Report drive region setting
111111b	None	Invalid Specified AGID (Reset Authentication sequence)
All other value		Reserved

Table 5.105: Key Format Code definition for REPORT KEY command

⁵¹AGID: Authentication Grand ID

In case of KEY Format = 000100b, the Reserved/Logical Block Address field specifies the logical block address which contain the TITLE-KEY to be sent to the Host obfuscated by a Bus-Key. In all other cases, this field is reserved.

5.38.1 Returns Authentication Grand ID (Format 000000b)

The REPORT KEY command with KEY Format field of 000000b begins the authentication process. The DVD-ROM drive, when ready to begin the authentication process, shall grant the request by returning an AGID. If there is no available AGID, the command is terminated with CHECK CONDITION status. The sense key is set to ILLEGAL REQUEST and the additional sense code to SYSTEM RESOURCE FAILURE.

	7	6	5	4	3	2	1	0	NOTE	
00	(MSB)	Data Length								00h
01								(LSB)	06h	
02		Reserved							00h	
03									00h	
	<i>AUTHENTICATION GRANT ID</i>									
04									00h	
05		Reserved							00h	
06									00h	
07	AGID									

Table 5.106: REPORT KEY Data Format (With KEY Format = 000000b)

5.38.2 Returns Challenge Key (Format 000001b)

	7	6	5	4	3	2	1	0	NOTE	
00	(MSB)	Data Length								00h
01								(LSB)	0Eh	
02		Reserved							00h	
03									00h	
	<i>Challenge-KEY</i>									
04	(MSB)									
⋮		Challenge-KEY Value								⋮
13								(LSB)		
14		Reserved							00h	
15									00h	

Table 5.107: REPORT KEY Data Format (With KEY Format = 000001b)

Challenge-KEY Value field returns a value to be used to interrogate an external device to determine conformance with the DVD Copy Protection scheme. The external device then generates the corresponding KEY2.

5.38.3 Returns KEY1 (Format 000010b)

	7	6	5	4	3	2	1	0	NOTE	
00	(MSB)	Data Length								00h
01								(LSB)	0Ah	
02		Reserved								00h
03										00h
	<i>KEY1</i>									
04	(MSB)									
05										
06		KEY1 Value								
07										
08										
09										00h
10		Reserved								00h
11										00h

Table 5.108: REPORT KEY Data Format (With KEY Format = 000010b)

KEY1 Value field returns a value used to determine the Logical Unit's conformity with DVD Copy Protection scheme by a external device. The KEY1 value will also be used as a parameter to generate a Bus-Key in the DVD-ROM drive.

5.38.4 Returns TITLE KEY (Format 000100b)

	7	6	5	4	3	2	1	0	NOTE	
00	(MSB)	Data Length								00h
01								(LSB)	0Ah	
02		Reserved								00h
03										00h
	<i>TITLE-KEY</i>									
04	<i>Copyright Management Information</i>									
	CPM	CP_SEC	CGMS	Reserved						
05	(MSB)									
06										
07		TITLE KEY Value								
08										
09										
										(LSB)
10		Reserved								00h
11										00h

Table 5.109: REPORT KEY Data Format (With KEY Format = 000100b)

- The CPM field identifies the presence of copyrighted material this sector.
 - 0b Material not copyrighted
 - 1b Copyrighted material
- The CP_SEC field indicates that the specified sector has a specific data structure for copyright protection system:

- 0b** No Such data structure exists in the sector
- 1b** A specific data structure exists in this sector
- The CGMS field indicates the restrictions on copying:
 - 00b** Copying is permitted without restriction
 - 01b** Reserved
 - 10b** One generation of copies may be made
 - 11b** No copying is allowed

TITLE-KEY Value field returns the TITLE-KEY which is obfuscated by a Bus-Key.
The length of TITLE-KEY Value is currently 5 bytes only.

When the TITLE-KEY does not exist in specified address on DVD media, this command with KEY Format = 000100b is terminated with CHECK CONDITION status. The sense key is set to ILLEGAL REQUEST and the additional sense code & qualifier set to COPY PROTECTION KEY EXCHANGE FAILURE -- KEY NOT PRESENT.

When the DVD-ROM drive is not in the Bus-Key Established state, this command with KEY Format = 000100b is terminated with CHECK CONDITION status. The sense key is set to ILLEGAL REQUEST and the additional sense code & qualifier set to COPY PROTECTION KEY EXCHANGE FAILURE -- KEY NOT ESTABLISHED.

5.38.5 Returns Authentication Success Flag (Format 000101b)

	7	6	5	4	3	2	1	0	NOTE	
00	(MSB)	Data Length								00h
01								(LSB)	06h	
02	Reserved								00h	
03	Reserved								00h	
<i>AUTHENTICATION SUCCESS FLAG</i>										
04	Reserved								00h	
05	Reserved								00h	
06	Reserved								00h	
07								Success Flag	00/01h	

Table 5.110: REPORT KEY Data Format (With KEY Format = 000101b)

5.38.6 Returns Drive Region Setting (Format 001000b)

Type Code field specifies the current state of the Regionalization Process.

00b	NONE	No drive region setting
01b	SET	Drive region is set
10b	LAST CHANCE	Drive region is set, with additional restrictions required to make a change
11b	PERM	Drive region has been set permanent, but may be reset if necessary

of Manufacturer Reset Available is a count down counter that indicates the number of times that the manufacturer can reset the region.

of User Controlled changes Available is a count down counter that indicates the number of times that the user/manufacturer can change the region.

	7	6	5	4	3	2	1	0	NOTE	
00	(MSB) Data Length								00h	
01									(LSB)	06h
02	Reserved									00h
03										00h
<i>DRIVE REGION SETTING</i>										
04	Type Code	# of Manufacturer Reset Available			# of User Controlled changes Available					
05	Region Mask									
06	RPC Scheme									
07	Reserved								00h	

Table 5.111: REPORT KEY Data Format (With KEY Format = 001000b)

Region Mask returns a value that specifies the drive region in which the drive is located. Once the drive region has been set, the drive is located in only one region. Each bit represents one of eight regions. If a bit is Cleared in this field, the disc can be played in the corresponding region. If a bit is Set in this field, the disc cannot be played in the corresponding region.

RPC Scheme specifies the type of Region Playback Controls being used by the drive.

00h	Unknown	The drive does not enforce Region Playback Controls(RPC).
01h	RPC Phase II	The drive adhere to this specification and all requirements of the CSS lisense agreement concerning RPC.
<i>Others</i>	<i>Reserved</i>	

5.39 PLAY AUDIO(12) command

Audio CD medium installed only valid.

	7	6	5	4	3	2	1	0	NOTE
00	Operation Code								A5h
01	LUN			Reserved					00h
02	(MSB)								
03	Starting Logical Block Address								
04									
05									(LSB)
06	(MSB)								
07	Transfer(Play) Length								
08									
09									(LSB)
10	Reserved								00h
11							Flag	Link	

COMMAND FUNCTION

Request the drive to begin an audio playback operation from the specified logical block address.

< Command Type > : Optional

< Starting Logical Block Address > : Specifies the starting block address at which the audio playback operation shall begin.

< Transfer Length > : The number of logical blocks to be played.

DESCRIPTION

This command requests the DVD-ROM drive to search and start an audio playback operation from the specified logical block address and to complete audio playback when specified blocks have been played.

The function is same as PLAY AUDIO(10) command and the only difference is Transfer Length field.

This command can specify up to FFFFFFFh(4294967295d) blocks of transfer length and it covers entire address of one CD medium, while PLAY AUDIO(10) command covers FFFFh(65535d) blocks which corresponds to 14min 33sec 60frame.

For a description of each fields in this command, refer to 5.26 PLAY AUDIO(10) command.

5.40 SET READ AHEAD command

	7	6	5	4	3	2	1	0	NOTE
00	Operation Code								A7h
01	LUN			Reserved					00h
02	(MSB)								
03	Trigger Logical Block Address								
04									
05	(LSB)								
06	(MSB)								
07	Read Ahead Logical Block Address								
08									
09	(LSB)								
10	Reserved								00h
11							Flag	Link	

COMMAND FUNCTION

Requests the drive performs the Read Ahead Caching operation from the Read-Ahead Logical Block Address when the drive encounters the Trigger Logical Block Address during its internal Read Ahead Caching operation.

< Command Type > : Mandatory (Real Time Streaming)

DESCRIPTION

When the DVD-ROM drive received this command when data after the Trigger Logical Block Address and before the Read Ahead Logical Block Address is contained in its cache, that data should be discarded and Read Ahead Caching re-started from the specified Read Ahead Logical Block Address.

Sectors after the Trigger LBA (Not including the Trigger LBA) should be skipped. The data for both the Trigger and Read Ahead LBAs will normally be read by the host. The sectors between these addresses (exclusive) are normally not read by host.

The Read-Ahead operation is performed in background, *i.e.* the DVD-ROM drive accept a command during the Read-Ahead operation.

5.41 READ(12) command

	7	6	5	4	3	2	1	0	NOTE
00	Operation Code								A8h
01	LUN		DPO	FUA	Reserved		RelAdr		00/08h
02	(MSB)								
03	Logical Block Address								
04									
05									
06	(MSB)								
07	Transfer Length								
08									
09									
10	Reserved								00h
11							Flag	Link	

COMMAND FUNCTION

Request the drive to transfer C/DVD-ROM data specified by the logical block address and transfer length.

- < Command Type > : Mandatory (DVD Read)
- < DPO > : DPO bit is not used by drive and should be set to **one**.
- < FUA > : FUA bit is indicate to use cache or not.
- < RelAdr > : bit is not used by drive and should be set to **zero**.
- < Logical Block Address > : Specifies the logical block address at which the read operation shall begin.
- < Transfer Length > : The number of logical block to be transferred.

DESCRIPTION

This command requests the DVD-ROM drive to transfer C/DVD data specified by the logical block address and transfer length.

The command function is same as READ (10) command except for Transfer Length field. This command can specify up to 4294967295d (FFFFFFFFh) blocks of transfer length and it covers entire address of one CD (CD-ROM) medium, while READ (10) command covers 65535d (FFFFh) blocks. For a description of each fields except for Transfer Length, refer to 5.20 READ (10) command.

5.42 GET PERFORMANCE command

	7	6	5	4	3	2	1	0	NOTE
00	Operation Code								ACh
01	LUN		Tolerance		Write		Except		
02	(MSB)								
03	Starting LBA								
04									
05									(LSB)
06	Reserved								00h
07									00h
08	(MSB)		Maximum Number of Descriptors						
09									(LSB)
10	Reserved								00h
11							Flag	Link	

COMMAND FUNCTION

This command provides a method for the host to profile the performance of the drive.

< Command Type > : Mandatory (Read Time Streaming)

DESCRIPTION

This command can report two forms: the nominal performance and exception locations that may cause seek delays to occur. These performance parameters are reported separately for read and write.

Tolerance field, when set to 10b, indicates that the descriptors returned have a 10% tolerance for the nominal performance and 20% for the exception list. All other values are reserved for future standardization.

Write bit, when set to **zero**, indicates that the performance parameters for reading is returned. The DVD-ROM drive is read-only device so this bit should be set to **zero**.

Except field, when set to 00b, indicates that the nominal performance parameters be returned. When set to 01b, the entire performance exception list is returned. When set to 10b, only performance exceptions that cause the performance to fall outside the nominal is reported.

Starting LBA field is valid only when Except = 01b. If Except = 01b, the Starting LBA field indicates the starting point for returning performance data. All performance data are for logical block addresses equal to this field or greater.

Maximum Number of Descriptors indicates the maximum number of descriptors that the drive returns.

The result data is formatted as follows:

Performance Data Length field specifies the amount of result data that follows the Performance Data Length field.

Write bit, when set to **zero**, indicates that the result data is for read performance.

Except bit, when set to **zero**, indicates that the result data is for nominal performance. When set to **one**, indicates that the result data is for exception conditions.

Performance Descriptors will be returned for the current medium. If no media is present, Performance Descriptors for the fastest medium will be returned.

The Performance Descriptors for nominal performance are intended to give the host an approximation of drive performance. All numbers are nominal. On CD media, all sectors will be reported as 2352 bytes/sector.

	7	6	5	4	3	2	1	0	NOTE
00	(MSB)								
⋮	Performance Data Length								⋮
03	(LSB)								
04							Write	Except	00/01h
⋮	Reserved								⋮
07									00h

Table 5.112: Performance Header

	7	6	5	4	3	2	1	0	NOTE
00	(MSB)								
⋮	Start LBA								⋮
03	(LSB)								
04	(MSB)								
⋮	Start Performance								⋮
07	(LSB)								
08	(MSB)								
⋮	End LBA								⋮
11	(LSB)								
12	(MSB)								
⋮	End Performance								⋮
15	(LSB)								

Table 5.113: Performance Descriptor - Nominal Performance

Start LBA field contains the first logical block address of the extent described by this descriptor.

Start Performance field contains the nominal drive performance at the Start LBA in *KB/s*.

End LBA field contains the last logical block address of the extent described by this descriptor.

End Performance field contains the nominal drive performance at the End LBA in *KB/s*.

	7	6	5	4	3	2	1	0	NOTE
00	(MSB)								
⋮	LBA								⋮
03	(LSB)								
04	(MSB)								
⋮	Time								⋮
05	(LSB)								

Table 5.114: Performance Descriptor - Exception

LBA field indicates that there is a seek delay between (LBA - 1) and LBA.

Time field indicates the expected additional delay between (LBA - 1) and LBA from nominal, in units of tenths of milliseconds (100 μ seconds). This seek delay may be due to linear replacement, zone boundaries, or other media dependent features. The expect additional delay represents the typical time expected for the type of exception described.

5.43 READ DVD STRUCTURE command

When this command is presented for a CD medium, it is terminated with CHECK CONDITION status. The sense key is set to ILLEGAL REQUEST and the additional sense code set to CAN NOT READ MEDIUM --- INCOMPATIBLE FORMAT (5/30/02).

	7	6	5	4	3	2	1	0	NOTE
00	Operation Code								ADh
01	LUN			Reserved					00h
02	(MSB)								00h
03	Reserved for RMD Block Number								00h
04									00h
05	(LSB)								00h
06	Layer Number								
07	Format								
08	(MSB) Allocation Length								
09	(LSB)								
10	AGID		Reserved						
11							Flag	Link	

COMMAND FUNCTION

Requests that the drive transfer data from areas on the DVD Media to the Host Computer. There are several control structures on the DVD media, including the Lead-in and Burst Cutting Area(BCA). The Lead-in area for DVD media contain information about the media as well as information used by the drive to allow it to recover information from the media. The BCA for DVD media is optional which contents is specified by media manufacture.

< Command Type > : Mandatory (DVD Read, DVD CSS)

< Layer Number field > : Starting layer number for which the DVD STRUCTURE data will be returned.

< Format field > : Type of information that is requested be send to the host.

< AGID field > : Described in the REPORT KEY command. This field is used only when the Format field contain 2h, for all other valued is reserved.

FORMAT CODE	RETURNED DATA	LAYER BYTE USAGE	ADDRESS FIELD	DATA-IN DESCRIPTION
00h	Physical	Layer Number	Reserved	DVD Lead-in area data
01h	Copyright	Layer Number	Reserved	Media Copyright information
02h	Disc Key	Reserved	Reserved	Disc Key obfuscated by using a BUS Key
03h	BCA	Reserved	Reserved	Media BCA information
04h	Manufacture's	Layer Number	Reserved	Disc manufacturing information
05h	CGMS,CPM	Layer Number	LBA	CGMS,CPM information
FFh	Structure List	Layer Number	Reserved	List of present in the specific Layer
Others	Reserved			

DESCRIPTION

The DVD STRUCTURE Data Length specifies the length in bytes of the following DVD STRUCTURE data that is available to be transferred to the Host. The DVD STRUCTURE Data Length value does not include the DVD STRUCTURE Data Length field itself.

The Length of Layer Information specifies the length in bytes of a Layer Information that follow.

The information for the starting layer specified by the Layer Number field in the Command Packet. If there is only one layer then the only valid layer is layer 0. If a non-existent layer

	7	6	5	4	3	2	1	0	NOTE
00	(MSB) DVD STRUCTURE Data Length								08h
01									(LSB) 02h
02	Reserved								00h
03									00h
<i>DVD Lead-in Structure(s)</i>									
04	Book Type				Book Version				
05	Disc Size				Minimum Rate				
06	Reserved	Number of Layers		TrackPath	Layer Type				
07	Linear Density				Track Density				
08	Reserved								00h
09	(MSB)								03h
10	Starting Physical Sector Number of Data Area								00h
11									(LSB) 00h
12	Reserved								00h
13	(MSB)								
14	End Physical Sector Number of Data Area								
15									(LSB)
16	Reserved								00h
17	(MSB)								
18	End Sector Number in Layer 0								
19	(Opposite recorded disc only)								(LSB)
20	BCA Flag	Reserved							00/80h
21									00h
⋮	Media Specific (Reserved)								⋮
2051									00h

Table 5.115: READ DVD STRUCTURE Data Format (= 00h)

is requested then the command is aborted with an **INVALID FIELD IN THE COMMAND PACKET** error. If the media has more than one layer, but is recorded using the Opposite Track Path method, then the same information is returned for all layers.

5.43.1 Lead-in Structure (Format 00h)

Book Type field specifies which DVD Book this media complies with.

0000b : DVD Read-Only Disc DVD-ROM
 0001b : DVD Rewritable Disc DVD-RAM (*Not Supported*)
 0010b : DVD Recordable Disc DVD-R
 1001b : DVD Rewritable Disc DVD+RW (*Not Supported*)
 Others : *Reserved*

Book Version specifies the version of the specified book that this media complies with (Physical Specification).

0001b : Version 1.0
 Others : *Reserved*

Disc Size specifies the physical size of the Media.

0000b : 120mm disc
 0001b : 80mm disc
 Others : *Reserved*

Minimum Rate is used to specify to the device the read rate to use for this media.

0000b	:	2.52Mbps
0001b	:	5.04Mbps
0010b	:	10.08Mbps
1111b	:	Not Specified
Others	:	Reserved

Number of Layers field specifies the number of layers for this side of the media.

00b	:	Single layer disc
01b	:	Dual layer disc
Others	:	Reserved

TrackPath bit specifies the direction of the layers when more than one layer is used.

If the bit is cleared to **zero** then this media uses Parallel Track Path(PTP). When PTP is used each layer is independent and has its own Lead-in and Lead-out areas on the media.

If the bit is set to **one** then the media uses Opposite Track Path(OTP). With opposite track path both layers are tied together, there is only one Lead-in and Lead-out. In the middle of the media there is an area called the middle area. The addresses of blocks in one layer are mirrored in the other layer.

0b	:	Parallel track path or Single Layer disc
1b	:	Opposite track path disc

Layer Type field read/write-ability of the layer. Only a value of **one** indicating that the media is read only is specified today.

If indicates **zero** then inserted media is old format (may be incompatible media).

0001b	:	Read-only layer
0010b	:	Recordable layer
0100b	:	Rewritable layer (<i>Not Supported</i>)
Others	:	Reserved

Linear Density field indicates the minimum/maximum pit length used for this layer.

0000b	:	0.267 $\mu\text{m}/\text{bit}$
0001b	:	0.293 $\mu\text{m}/\text{bit}$
0010b	:	0.409 to 0.435 $\mu\text{m}/\text{bit}$ (<i>Not Supported</i>)
1000b	:	0.176 $\mu\text{m}/\text{bit}$ (<i>Not Supported</i>)
Others	:	Reserved

Track Density field indicates the track width used for this media.

0000b	:	0.74 $\mu\text{m}/\text{track}$
0001b	:	0.80 $\mu\text{m}/\text{track}$ (<i>Specified for Recordable Disc</i>)
0010b	:	<i>reserved for Rewritable Disc</i>
Others	:	Reserved

Starting Sector Number of Main Data field specifies the first block that contains user data.

30000h	:	DVD-ROM and DVD-R
31000h	:	DVD-RAM and DVD+RW (<i>Not Supported</i>)
Others	:	Reserved

End Sector Number of Main Data field specifies the last sector of the user data in the layer.

End Sector Number in Layer 0 field specifies the last sector of the user data in layer 0.

If the media does not use Opposite Track Path and contain Multiple Layers, this value is set to 000000h.

BCA flag indicates the presence of data in the Burst Cutting Area.

A bit of **zero** indicates BCA⁵² data does not exist, a bit of **one** indicates BCA data may be exist. BCA data to be record after finishing disc manufacturing process.

5.43.2 Copyright Information (Format 01h)

	7	6	5	4	3	2	1	0	NOTE	
00	(MSB)	DVD STRUCTURE Data Length								00h
01								(LSB)	06h	
02			Reserved						00h	
03									00h	
<i>DVD Copyright Information</i>										
04		Copyright Protection System Type								00/01h
05		Region Management Information								
06			Reserved						00h	
07									00h	

Table 5.116: READ DVD STRUCTURE Data Format (= 01h)

Copyright Protection System Type field indicates the presence of data structures specific to a copyright protection system. Only two values are defined, 00h indicates there is no such data and 01h indicates a specific data structure exists.

Region Management Information field describes the regions in which the disc can be played. Each bit represents one of eight regions.

If a bit is cleared in this field, the disc can not be played in the corresponding region.

If a bit is set in this field, the disc can be played in the corresponding region.

		Following Bit zero indicates capable to play MPEG-2 DVD title	
BIT		DESCRIPTION	
0	Region #1	:	Canada, USA, Bermuda, Midway, Puerto Rico, etc.
1	Region #2	:	Europe, Middle East, Japan, South Africa, UK, Greenland, etc.
2	Region #3	:	Southeast Asia, Korea, Hong Kong, Macao, Taiwan, etc.
3	Region #4	:	Oceania, South America, Mexico, Cuba, Guam, etc.
4	Region #5	:	Africa, Middle Asia, Russia, North Korea, etc.
5	Region #6	:	China
6	Region #7	:	Reserved
7	Region #8	:	Reserved

Table 5.117: Region Code Table

This region management control use for DVD-Video disc only, other disc's all bits should be se to **zero**.

5.43.3 Disc Key Structures (Format 02h)

DISC KEY Value field returns the DISC KEY which is obfuscated by a Bus key. The length of DISC KEY value is currently 2048 bytes only.

⁵²BCA : Burst Cutting Area

	7	6	5	4	3	2	1	0	NOTE
00	(MSB) DVD STRUCTURE Data Length								08h
01									(LSB) 02h
02	Reserved								00h
03									00h
<i>Disc Key Structures</i>									
04	(MSB) DISC KEY Data								
⋮									⋮
2051									(LSB)

Table 5.118: READ DVD STRUCTURE Data Format (= 02h)

When the DISC KEY does not exist on DVD media, this command with Format = 02h is terminated with CHECK CONDITION status. The sense key is set to ILLEGAL REQUEST and the additional sense code set to COPY PROTECTION KEY EXCHANGE FAILURE --- KEY NOT PRESENT.

When the DVD-ROM drive is not in the Bus Key state, this command with Format = 02h is terminated with CHECK CONDITION status. The sense key is set to ILLEGAL REQUEST and the additional sense code set to COPY PROTECTION KEY EXCHANGE FAILURE --- KEY NOT ESTABLISHED.

5.43.4 BCA Structures (Format 03h)

	7	6	5	4	3	2	1	0	NOTE
00	(MSB) DVD STRUCTURE Data Length								
01									(LSB)
02	Reserved								00h
03									00h
<i>DVD BCA Structures</i>									
04	(MSB) BCA Information								
⋮									⋮
NN									(LSB)

Table 5.119: READ DVD STRUCTURE Data Format (= 03h)

The Length of BCA Information is in the range of 12 to 188 bytes.

If without BCA information media inserted and this requested, then drive is terminated with CHECK CONDITION status. The sense key is set to ILLEGAL REQUEST and the additional sensecode set to INVALID FIELD IN COMMAND PACKET.

BCA General Information

BCA is an area for recording information after finishing disc manufacturing process. The BCA-Code is readable by an optical pickup defined in the Measuring conditions. The BCA-Code can be written by a YAG laser system. It is not excluded to write the BCA-Code through replication process using pre-pits if read-out signal which satisfy the BCA-Code read-out signal specification is read therefrom. This BCA-Code is specified as an option for only single side DVD-ROM disc.

Location of BCA and Lead-in Area

The BCA shall be located between $22.3_{-0.4}^{+0.0}mm$ and $23.50\pm 0.05mm$ from the center of the center hole. Starting diameter of the Lead-in Area shall not execute $44.5mm$ when the BCA-Code is applied.

5.43.5 Disc manufacturing Information (Format 04h)

	7	6	5	4	3	2	1	0	NOTE
00	(MSB) DVD STRUCTURE Data Length								08h
01									(LSB) 02h
02	Reserved								00h
03									00h
<i>DVD Lead-in Structures</i>									
04	(MSB)								
⋮	Disc Manufacturing Information								⋮
2051									(LSB)

Table 5.120: READ DVD STRUCTURE Data Format (= 04h)

The Disc Manufacturing Information is taken from DVD media lead-in area.
Text or code data written by the disc manufacturer with free format.

5.43.6 Copyright Management Information (Format 05h)

	7	6	5	4	3	2	1	0	NOTE
00	(MSB) DVD STRUCTURE Data Length								00h
01									(LSB) 06h
02	Reserved								00h
03									00h
<i>Copyright Management Information</i>									
04	CPM	Reserved	CGMS						
05									00h
06	Reserved								00h
07									00h

Table 5.121: READ DVD STRUCTURE Data Format (= 05h)

CPM bit, if set to **zero**, indicates that this sector contains no copyright material. If the CPM bit is set to **one**, indicates that this sector contains copyright material.

When the CPM bit set to **zero**, the CGMS field is set to 00b. When the CPM bit is set to **one**, and if the CGMS field is set to 00b, indicates that copying is permitted without restriction, and if the CGMS field is set to 01b, indicates that the CGMS field is reserved, and if the CGMS field is set to 10b, indicates that one generation of copies may be made, and if the CGMS field is set to 11b, indicates that no copying is permitted.

5.43.7 Structure List (Format FFh)

	7	6	5	4	3	2	1	0	NOTE	
00	(MSB)	DVD STRUCTURE Data Length								00h
01								(LSB)	1Eh	
02	Reserved								00h	
03	Reserved								00h	
	<i>Structure List</i>									
04	Format Code								00h	
05	SDS	RDS	Reserved							40h
06	Structure List								08h	
07	Reserved								04h	
08	Format Code								01h	
09	SDS	RDS	Reserved							40h
10	Structure List								00h	
11	Reserved								08h	
12	Format Code								02h	
13	SDS	RDS	Reserved							40h
14	Structure List								08h	
15	Reserved								04h	
16	Format Code								03h	
17	SDS	RDS	Reserved							40h
18	Structure List								00h	
19	Reserved								C0h	
20	Format Code								04h	
21	SDS	RDS	Reserved							40h
22	Structure List								08h	
23	Reserved								04h	
24	Format Code								05h	
25	SDS	RDS	Reserved							40h
26	Structure List								00h	
27	Reserved								08h	
28	Format Code								FFh	
29	SDS	RDS	Reserved							40h
30	Structure List								00h	
31	Reserved								20h	

Table 5.122: READ DVD STRUCTURE Data Format (= FFh)

Format Code field identifies a DVD Structure that is readable via the READ DVD STRUCTURE command.

SDS bit, when set to **zero**, indicates that the DVD structure is not writable via the SEND DVD STRUCTURE command (not supported).

RDS bit, when set to **one**, indicates that the DVD structure is readable via the READ DVD STRUCTURE command.

Structure List field specifies the length of the DVD structure that is identified by the Format Code.

5.44 SET STREAMING command

	7	6	5	4	3	2	1	0	NOTE	
00	Operation Code								B6h	
01	LUN									00h
02									00h	
03									00h	
04									00h	
05	Reserved								00h	
06									00h	
07									00h	
08									00h	
09	(MSB)		Parameter List Length							
10									(LSB)	
11	Reserved						Flag	Link		

COMMAND FUNCTION

This command provides a way for the host to indicate to the drive that the application has specific request or requirements for drive performance.

< Command Type > : Mandatory (Real Time Streaming)

DESCRIPTION

This command provides a way for the host to indicate to the drive that the application has specific request or requirements for drive performance. The DVD-ROM drive may utilize the host supplied information to change mechanical or logical operation. The performance setting is persistent and remains until a new descriptor is sent. The setting only applies to the extent identified by the Start and End LBA field in table 5.123.

If the **SET STREAMING** command is used to set performance, the drive disable read (and write) reallocation in the specified region on order to meet the performance criteria.

RDD⁵³ bit, when set to **zero**, means that the remaining fields are valid. When set to **one**, indicates that the drive is to return to its default performance settings and the remaining fields in this descriptor is ignored. Read (and Write) reallocation ability is restored to operation specified by the Read/Write Error Recovery page (refer to *pp.55*).

Exact bit, when set to **zero**, indicates that the DVD-ROM drive set its internal configuration to match the parameters as best as possible. No errors occur.

When set to **one**, indicates that the DVD-ROM drive set its internal configuration to support the requested parameters. *Not supported*.

MRW⁵⁴ bit, when set to **zero**, allows the drive to independently set the read (and write) speeds. When set to **one**, indicates to the drive that its performance settings should be optimized for random changes between reading and writing by the host.

Start LBA field is the first logical block for which the performance request is being made.

End LBA field is the last logical block for which the performance request is being made.

The data rate to be delivered for reading is $\frac{ReadSize}{ReadTime}$.

⁵³RDD : Restore Drive Defaults

⁵⁴MRW : Mixed Read/Write

	7	6	5	4	3	2	1	0	NOTE
00						RDD	Exact	MRW	
01									00h
02				Reserved					00h
03									00h
04	(MSB)								
05				Start LBA					
06									
07								(LSB)	
08	(MSB)								
09				End LBA					
10									
11								(LSB)	
12	(MSB)								
13				Read Size					
14									
15								(LSB)	
16	(MSB)								
17				Read Time					
18									
19								(LSB)	
20	(MSB)								00h
21				Write Size					00h
22									00h
23								(LSB)	00h
24	(MSB)								00h
25				Write Time					00h
26									00h
27								(LSB)	00h

Table 5.123: Performance Descriptor

Read Size field shall indicate the number of kilo-bytes the host expects to be delivered per period of Read Time when the host's requests for data occur sufficiently fast.

Read Time field shall indicate the amount of time, in milli-seconds, over which the Read Size is expected to be read.

The host may set these two fields by setting Read Size to the size of its application's buffer and the Read Time to the amount of time it takes to empty that buffer.

Write Size, Write Time fields, the DVD-ROM drive does not support write function, so these fields are reserved.

5.45 READ CD MSF command

CD medium installed only valid.

	7	6	5	4	3	2	1	0	NOTE
00	Operation Code								B9h
01	LUN			Expected Sector Type			Reserved		
02	Reserved								00h
03	Starting M field								
04	Starting S field								
05	Starting F field								
06	Ending M field								
07	Ending S field								
08	Ending F field								
	<i>Flag Bits</i>								
09	SYNCH	Header(s) Code		User Data	EDC&ECC	Error Flag(s)		Reserved	
10	Reserved					Sub-Channel Data Selection Bits			
11							Flag	Link	

COMMAND FUNCTION

Request the drive to transfer any of the CD data stream, including the header, EDC & ECC, CD-ROM and CD-DA data etc.

< Command Type > : Mandatory (CD Audio, Analog Play)

< Expected Sector Type > : Specifies the information type that the Host Computer requires.

< M/S/F Field > : The MSF address at which the read operation shall begin/end.

< Flag Bits > : Specifies the portion of the CD data stream to be transferred.

< Sub-Channel Data Selection Bits > : Which CD Sub-Channel information is to be included in the data stream.

DESCRIPTION

This command requests the DVD-ROM drive to transfer any of the CD data stream, including the CD-ROM synch pattern, CD-ROM header, CD-ROM EDC & ECC, error flag, Subcode data and CD-ROM and CD-DA data.

The command function is same as the READ CD command except for the Starting or Ending M/S/ F Field.

For a description of each fields except for below, refer to 5.49 READ CD command.

Starting M Field, S Field and F Field specifies the CD-ROM header or absolute CD address (Minutes, Second and Frame) at which the read operation shall begin.

M field has a value between 00h to 63h (99d), S Field has a value between 00h to 3Bh (59d) and F Field has a value between 00h to 4Ah (74d).

Ending M Field, S Field and F Field specifies the CD-ROM header or absolute CD address (Minutes, Second and Frame) at which the read operation shall end.

All contiguous sector data between the starting and the ending MSF address is transferred.

If the starting MSF address is equal to the ending MSF address, the DVD-ROM drive returns a status immediately and no data is transferred.

If the starting MSF address is greater than the ending MSF address, the DVD-ROM drive terminates the command with CHECK CONDITION status.

Following shows examples of command implementation.

STARTING MSF	ENDING MSF	DESCRIPTION
0A:00:00 (10:00:00)	09:3B:4A (09:59:74)	Return a CHECK CONDITION
0A:00:00 (10:00:00)	0A:00:00 (10:00:00)	Return a good status immediately without transferring data.
0A:00:00 (10:00:00)	0A:00:01 (10:00:01)	Transfer one block data.

5.46 SCAN command

Audio CD medium installed only valid.

	7	6	5	4	3	2	1	0	NOTE
00	Operation Code								BAh
01	LUN			DIRECT	Reserved			RelAdr	00/10h
02	(MSB)								
03	Scan Starting Address								
04									
05									(LSB)
06									00h
07									00h
08	Reserved								00h
09	Type								
10									00h
11							Flag	Link	

COMMAND FUNCTION

Request the drive to begin an audio scan (fast-forward or fast-reverse) operation.

< Command Type > : Optional (CD Audio, Analog Play)

<DIRECT > : Specifies the direction of audio scan (0: FWD, 1: BWD)

<RelAdr > : This bit is not used by drive and should be set to **zero**.

< Scan Starting Address > : Specifies the Subcode-Q address at which the audio scan operation shall start.

< Type > : Specifies the block addressing mode as follows.

00b : Logical block address

01b : CD Subcode-Q absolute time (ATIME⁵⁵)

10b : CD Track Number (TNO)

11b : Reserved

DESCRIPTION

This command requests the DVD-ROM drive to begin an audio scan (fast-forward or fast-reverse) operation.

The audio scan operation of the DVD-ROM drive is defined as an operation that the DVD-ROM drive executes track jumps periodically and do audio playback between track jumps.

There is no ending address in the Command Packet and this command scans all the way to the end of the media.

The DVD-ROM drive enters Idle state upon receipt of a **STOP SCAN/PLAY** command during audio scan, and if the DVD-ROM drive receives a **PAUSE/RESUME** command with the resume bit set to **zero**, the drive starts pause operation. After that, if the DVD-ROM drive receives a **PAUSE/RESUME** command with the resume bit set to **one**, the DVD-ROM drive resumes audio play (note: not audio scan) from the address where the audio pause occurred.

If the DVD-ROM drive receives an **SCAN** command during play or pause, the DVD-ROM drive stops play or pause and performs audio scan. Upon receipt of a **READ SUB CHANNEL** command during audio scan, the DVD-ROM drive returns audio status of **11h** (Audio play operation in progress).

If the DVD-ROM drive receives an **SCAN** command during play or pause for which a valid stop address was specified, the DVD-ROM drive remembers the stop address but ignores it during audio scan. The stop address becomes valid again when audio play resumes. Thus, upon

⁵⁵ATIME: Absolute Time (AMIN:ASEC:AFRAME)

resumption of audio play, if the current address is greater than the former stop address, the DVD-ROM drive stops playing and returns good status. After this, if the DVD-ROM drive receives a READ SUB CHANNEL command, the DVD-ROM drive returns an audio status of 13h (Audio play operation successfully completed).

If the DVD-ROM drive reaches a data track, it stops audio scan.

Although the audio control page of the MODE SELECT parameters is available, the DVD-ROM drive attenuates the output to be 50% automatically if the specified output level is greater than 80h.

As well as PLAY AUDIO commands, the DVD-ROM drive returns a status as soon as the audio scan operation starts and DSC bit is set to **one** at completion of audio scan operation.

Note: That the Host Computer is able to recognize the command completion (Audio scan completion) with a READ SUB-CHANNEL or REQUEST SENSE command.

DIRECT bit of **zero** indicates a fast-forward operation and set to **one** indicates a fast-reverse operation.

Scan Starting address specifies the address at which the audio scan operation shall begin.

Type bits select to scan method to execute scan operation.

Type 00b : Scan by LBA

Scan Starting Address specified with the logical block address.

	7	6	5	4	3	2	1	0	NOTE
02	(MSB)								
03	Starting Logical Block Address								
04									
05	(LSB)								

Type 01b : Scan by ATIME

Scan Starting Address specified with CD Subcode-Q Absolute Time Address (ATIME) which is the physical address prescribed in CD standard.

The AMIN has a range of 00h to 63h (99d). ASEC has a range of 00h to 3Bh (59d) and AFRAME has a range of 00h to 4Ah (74d).

Namely the MSF address field is binary.

	7	6	5	4	3	2	1	0	NOTE
02	Reserved								00h
03									(MIN)
04	CD Subcode-Q absolute Time Address								(SEC)
05									(FRAME)

Type 10b : Scan by TNO

Scan Starting Address specified with CD track number (TNO) which is also physical address prescribed in CD standard. This field has a range of 01h to 63h.

	7	6	5	4	3	2	1	0	NOTE
02	Reserved								00h
03	Reserved								00h
04	Reserved								00h
05	CD-ROM TNO (Track Number)								

5.47 SET CD SPEED command

Effect for CD medium access only.

	7	6	5	4	3	2	1	0	NOTE
00	Operation Code								BBh
01	LUN			Reserved					00h
02	(MSB) Read Drive Speed in Kbytes/Second								
03									(LSB)
04	(MSB) Write Drive Speed in Kbytes/Second								00h
05									(LSB)
06									00h
07									00h
08	Reserved								00h
09									00h
10									00h
11							Flag	Link	

COMMAND FUNCTION

Specify the spindle rotation speed (data transfer rate) while reading CD-ROM data.

This command is not effective for DVD data transfer.

< Command Type > : Optional

< Read Drive Speed > : Specifies the data transfer rate in kilobytes/second.

< Write Drive Speed > : DVD-ROM drive not support WRITE function.

DESCRIPTION

This command is used to specify the spindle rotational speed (data transfer rate to the Host Computer) while reading CD-ROM data.

Note : That this setting is ignored for CD audio playback initiated by PLAY AUDIO commands. The DVD-ROM drive operates at low speed during these modes.

The Host Computer can specify the rate up to FFFFh but the DVD-ROM drive chooses following speed for specified rate.

MODE	CD-DA(AUDIO)			CD-ROM(DATA)				
	Error	Sync	Async	Error	Low	Mid	High	Max
SD-M1401	0000h -	00B0h -	0DC8h -	0000h -	00B0h -	0DC8h -	134Bh -	1B90h -

Table 5.124: DATA Transfer Rate Change Threshold

The actual maximum speed supported is returned in the Capability and Mechanism Status page 2Ah in mode sense data. (pp.64)

5.48 MECHANISM STATUS command

	7	6	5	4	3	2	1	0	NOTE
00	Operation Code								BDh
01	LUN			Reserved					00h
02									00h
03									00h
04	Reserved								00h
05									00h
06									00h
07									00h
08	(MSB) Allocation Length								
09									(LSB)
10	Reserved								00h
11							Flag	Link	

COMMAND FUNCTION

Request the drive to transfer the current status.

< Command Type > : Mandatory (Removable)

< Allocation Length > : Maximum number of bytes that the Host Computer has allocated for the returned MECHANISM STATUS data.

DESCRIPTION

This command requests the DVD-ROM drive to transfer the current location relative to the beginning of the media, or elapsed time on the media.

The allocation length field specifies the maximum number of bytes that the Host Computer has allocated for the returned MECHANISM STATUS data. The DVD-ROM drive terminates the data transfer when the allocation length bytes have been transferred or when all available MECHANISM STATUS data have been transferred to the Host Computer, whichever is less.

	7	6	5	4	3	2	1	0	NOTE
00	Fault	Changer State	Current Slot						00h
01	Mechanism State			DoorOpen	Reserved				00/10h
02	(MSB)								
03	Current LBA								
04									(LSB)
05	Reserved			Number of Slots Available					00h
06	(MSB) Length of Slot Table(s)								00h
07									(LSB) 00h

Table 5.125: MECHANISM STATUS Data Format

As the DVD-ROM drive is not a changer, Fault, Changer State, Current Slot. The DVD-ROM drive Mechanism State, **Number of Slots Available** and **Length of Slot Table** field are Reserved.

Current LBA field shows the location that was last while reading or playing. While a Play is in progress this field will contain the LBA of the current block being processed.

DoorOpen bit indicates the DVD-ROM drive's tray/drawer is in open or close state. A bit of **one** indicates the drive is in a OPEN (or OPENING) status, a bit of **zero** indicates the drive is in a CLOSED status.

5.49 READ CD command

	7	6	5	4	3	2	1	0	NOTE																
00	Operation Code								BEh																
01	LUN			Expected Sector Type			Reserved	RelAdr																	
02	Logical Block Address																								
03									(MSB)																
04																									
05																									(LSB)
06	(MSB)																								
07									Transfer Length																
08																	(LSB)								
09																									Flag Bits
	Synch	Header(s) Code	User Data	EDC&ECC	Error Flag(s)	Reserved																			
10	Reserved				Sub-Channel Data Selection Bits																				
11							Flag	Link																	

COMMAND FUNCTION

Request the drive to transfer any of the CD data stream, including the header, EDC & ECC, CD-ROM and CD-DA data etc.

If DVD media inserted on the DVD-ROM drive, allow User Data transfer mode only.

< Command Type > : Mandatory (CD Read)

< Expected Sector Type > : Specifies the information type that the Host Computer requires.

<RelAdr > : bit is not used by drive and should be set to **zero**.

< Logical Block Address > : Specifies the logical block address at which the read operation shall begin.

< Transfer Length > : The number of logical blocks to be transferred.

< Flag Bits > : Specifies the portion of the CD data stream to be transferred.

< Sub-Channel Data Selection Bits > : Specifies which CD Sub-Channel information is to be included in the data stream.

DESCRIPTION

This command requests the DVD-ROM drive to transfer any of the CD data stream, including the CD synch pattern, CD-ROM header, CD-ROM EDC & ECC, error flag, Subcode data and CD-ROM and CD-DA data.

This command and **READ CD MSF** command provide one standard, universal way of accessing CD data and is generic to all CD data types.

Expected Sector Type is used to specify (limit) the information type to be transferred to the Host Computer.

Note that this field has no control of the actual number of bytes transferred but just has a function to limit the returned data type.

If the requested sector does not match the specified type, the command is terminated with a **CHECK CONDITION** and the sector that does not match is not transferred to the Host Computer.

Table 5.126 shows the Expected Sector Type definition.

Logical Block Address specifies the logical block address at which the read operation shall begin.

If this address is set to **FFFFFFFFh** and if the only information requested is the Sub-Channel data and if there is currently a **PLAY AUDIO** command in process, the actual address used will be from the current location of the optics.

EXPECTED SECTOR TYPE	DEFINITION	DESCRIPTION
000b	Any Type	Any type (CD-ROM, CD-DA and DVD-ROM) is allowed. The DVD-ROM drive terminates a command when a transition (CD-ROM and CD-DA) occurs during transfer.
001b	CD-DA Type	Only RED BOOK audio sectors are allowed. The DVD-ROM drive returns an ILLEGAL MODE FOR THIS TRACK error when a CD-ROM data sector is encountered.
010b	Mode-1	Only YELLOW BOOK mode-1 sectors which have a User Data field of 2048 bytes are allowed.
011b	Mode-2	Only YELLOW BOOK mode-2 sectors which have a User Data field of 2336 bytes are allowed.
100b	Mode-2 Form-1	Only GREEN BOOK (CD-I or CD-ROM XA disc) sectors which have a User Data field of 2048 bytes are allowed.
101b	Mode-2 Form-2	Only GREEN BOOK (CD-I or CD-ROM XA disc) sectors which have a User Data field of 2324 bytes are allowed. Note that the spare data (4 bytes) is included in the User Data making the size of 2328 (2324 + 4) bytes.
110 - 111b	<i>Reserved</i>	

Table 5.126: Expected Sector Type Definition

If the DVD-ROM drive is not playing audio, it returns a **CHECK CONDITION** with **AUDIO PLAY NOT IN PROGRESS** error code.

The transfer length field (Byte 06 to 08) specifies the number of logical blocks of data to be transferred.

A transfer length of zero indicates that no data is transferred.

Flag Bits specifies which information from the CD is to be returned in the data stream.

Flag Bits set to **zero** indicates that the particular information is not transferred.

If all flags are cleared, no data is transferred.

Following shows the definition of each Flag Bits.

1. Bit 7: Synch Field Bit
Set to **one** indicates that the CD synch pattern (12 bytes) will be included in the data stream.
2. Bit 6&5: Header(s) Code
Specify the CD-ROM Header/Sub-header information to be placed in the data stream as table 5.127.

HEADER CODE	DEFINITION	DESCRIPTION
00b	None	None of header is placed in the stream.
01b	Header only	Only the Mode-1 or Mode-2 header (4 bytes) is returned.
10b	Sub-header Only	Only the CD-ROM XA Form-1 or Form-2 Sub-header (8 bytes) is returned.
11b	All Headers	Both the header and sub-header is returned.

Table 5.127: Header(s) Code Definition

3. Bit 4: User Data

Set to **one** indicates that the Data part of a CD sector is returned in the data stream. Upon the sector type, following length of data is returned.

CD-DA	: 2352 bytes
Mode-1	: 2048 bytes
Mode-2	: 2336 bytes
Mode-2 Form-1	: 2048 bytes
Mode-2 Form-2	: 2328 bytes (2324 + 4)

4. Bit 3: EDC & ECC

Set to **one** indicates that the EDC and ECC field is included in the data stream. For Mode-1 sector, 288 bytes (280 + 8 bytes) is returned and 280 bytes is returned for Mode-2 Form-1 sector. For other sectors, this bit has no meaning (no data is transferred).

5. Bit 2&1: Error Flag(s)

Specify the CD-ROM the C2 and/or Block Error data will be included in the data stream as follows.

ERROR FLAGS	DEFINITION	DESCRIPTION
00b	None	No Error information will be included in the data stream.
01b	C2 Error Flag data	The C2 Error Flag (Pointer) bits (2352 bits or 294 bytes) will be included in the data stream. When the C2 Error pointer bits are included in the data stream, there will be one bit for each bytes in error in the sector (2352 total). The bit ordering is from the most significant bit to the least significant bit in each byte. The first bytes in the sector will be the first bits/bytes in the data stream.
10b	C2 & Block Error flags	Both the C2 Error Flags (2352 bits or 294 bytes) and the Block Error Byte will be included in the data stream. The block Error bytes is the OR of all the C2 Error Flag bytes. So that the data stream will always be an even number of bytes, the Block Error byte will be padded with a byte (undefined). The Block Error bytes will be first in the data stream followed by the pad byte.
11b	<i>Reserved</i>	<i>Reserved for future enhancement</i>

Table 5.128: Error Flag(s) Definition

Sub-Channel Data Selection Bit field indicates which CD Sub-Channel information is to be included in the data stream. Table 5.129 shows the definition.

Table 5.130 shows the number of bytes to be transferred based on Data Selection field.

Note: The Toshiba DVD-ROM drive returns raw subcode R thru W data (returned in the format and order found on the media), the Host Computer should de-interleave the data and perform error correction if necessary based on the Subcode R thru W specification.

SUB-CHANNEL DATA SELECTION	DEFINITION	DESCRIPTION
000b	No Sub-Channel Data	No Sub-Channel data is returned.
001b	RAW	Raw Sub-Channel data is transferred.
010b	Q	Q data is transferred.
011b		<i>Reserved</i>
100b	R-W	Toshiba DVD-ROM drive does not execute de-interleave or error correction for subcode R thru W and does not support this mode.
101 - 111b		<i>Reserved</i>

Table 5.129: Sub-Channel Data Selection Field Definition

	FLAGS BITS	CD-DA	Mode-1	Mode-2	Mode-2 Form-1	Mode-2 Form-2
Synch	80h	0	12	12	12	12
Header	20h	0	4	4	4	4
Synch & Header	A0h	0	16	16	16	16
Sub Header	40h	0	0	0	8	8
All Header	60h	0	4	4	12	12
Synch & Headers	E0h	0	16	16	24	24
User Data	10h	2352	2048	2336	2048	2328
Sub Header & User Data	50h	2352	2048	2336	2056	2336
Header & User Data	30h	2352	2052	2340	2052	2332
All Headers & User Data	70h	2352	2052	2340	2060	2340
Synch & All Headers & User Data	F0h	2352	2064	2352	2072	2352
Repeat All Above & Add EDC/ECC	08h	0	288	0	280	0
Repeat All Above & Add Error Flags	02h	0	294	294	294	294
Repeat All Above & Add Block & Error Flags	04h	0	296	296	296	296

Table 5.130: Number of Byte based on Data Selection Field

5.49.1 Read CD command for DVD Media

This command is define for multi-sector data transfer on CD, but DVD has only one sector format. DVD-ROM drive allow only one setting of parameter, if installed DVD media.

FACTOR	DEFINITION	BIT PATTERN
Expected Sector Type	Any Type	000b
Flag Bits	User Data	00010000b
Sub-Channel Data Selection Bits	None	00b

Table 5.131: Read CD command for DVD media

Chapter 6

SENSE DATA

The sense data is available when the previous command terminates with a **CHECK CONDITION** or may be available if the command ended with unexpected disconnect.

The sense data is preserved by the DVD-ROM drive for initiator until receiving of a **REQUEST SENSE** command or until receipt of any other command.

The DVD-ROM drive supports extended sense data format as shown in Table 6.1 consisting of 18 bytes.

	7	6	5	4	3	2	1	0	NOTE
00	Valid	Error Code (70h or 71h)							
01	Segment Number (Reserved)								00h
02	Reserved	ILI	Reserved	Sense Key					
03	(MSB)	Information							
04									
05									
06								(LSB)	
07	Additional Sense Length (=0Ah)								0Ah
08	(MSB)	Command Specific Information							00h
09									00h
10									00h
11								(LSB)	00h
12	Additional Sense Code								ASC
13	Additional Sense Code Qualifier								ASCQ
14	Field Replaceable Unit Code								00h
15	SKSV								
16		Sense-Key Specific							
17									

Table 6.1: Sense Data Format

Valid bit of **zero** indicates that the information field is not valid.

Valid bit of **one** indicates that information field contains valid information.

ILI¹ bit is not supported.

Sense Key field shows the generic categories of the error or exceptions as shown in Table 6.4.

Information field indicates the (error) address associated with the Sense Key and this field has valid information when **Valid** bit is set to **one**.

¹ILI: Illegal Length Indicator

One of following address is used depending upon the requested command.

1. Logical Block Address
2. CD-ROM Header Address or CD Subcode-Q Address
3. CD or CD-ROM Track Number

Additional Sense Length field specifies the additional sense bytes to follow and is fixed to be **0Ah** (10d) bytes for the DVD-ROM drive .

Additional Sense Code field shows the further error information in Sense Key field.

Additional Sense Code Qualifier field shows the detailed information related to the Additional Sense Code field.

Table 6.5,6.6 shows the list of Additional Sense Code (ASC) and Additional Sense Code Qualifier (ASCQ) defined for the DVD-ROM drive .

If the Sense Key is set to **ILLEGAL REQUEST** and the **SKSV**² bit (Byte 15, Bit 7) is set to **one**, the Sense-Key Specific field is defined as Field Pointer Bytes field as shown in Table 6.2 which describes the location of the parameters in command or parameters which are in error.

	7	6	5	4	3	2	1	0	NOTE
15	SKSV	C/D	Reserved	BPV	Bit Pointer				
16	(MSB)	Field Pointer							
17							(LSB)		

Table 6.2: Field Pointer Bytes

C/D³ bit of **one** indicates that the illegal parameter is in the Command Packet.

C/D bit of **zero** indicates that the error is in the parameters sent by the Host Computer.

BPV⁴ bit of **zero** indicates that the value of Bit Pointer field is not valid.

BPV bit of **one** indicates that the Bit Pointer field specifies which bit is in error.

Bit Pointer specifies which bit of the byte specified by the Field Pointer field is in error.

Field Pointer field indicates which byte of the Command Packet or the parameters was in error.

	7	6	5	4	3	2	1	0	NOTE
15	SKSV(1)	C/D	Reserved	BPV	Bit Pointer				
16	(MSB)	Sense-Key Specific							
17							(LSB)		

Table 6.3: Field Pointer Bytes

²Valid: Sense-Key Specific Valid

³C/D: Command/Data

⁴BPV: Bit Pointer Valid

6.1 Sense Key

SENSE KEY		DESCRIPTION
0h	No Sense	Indicates that there exists no specific sense data to return. This would be a case that the command executed preceding the REQUEST SENSE command completed successfully.
1h	Recovered Error	Indicates that the last command completed successfully with some error recovery operation, retry or error correction.
2h	Not Ready	Indicates that the drive is not ready and is not accessible.
3h	Medium Error	Indicates that the command execution terminated with an error that was probably caused by a defect on medium.
4h	Hardware Error	Indicates that the drive detected a non-recoverable hardware failure during command execution or during a self test.
5h	Illegal Request	Indicates that there was an illegal parameter in Command Packet or parameters as shown in below. <ol style="list-style-type: none"> 1. Illegal parameters are found in Command Packet or parameters. 2. The drive can not execute the requested command. 3. LUN other than zero is specified.
6h	Unit Attention	Indicate following unit attention. <ol style="list-style-type: none"> 1. The drive was reset by Power-On or RESET condition or BUS DEVICE RESET message. 2. Medium may have been changed.
7h	Data Protect	Not used
8h	Blank check	Indicates that the DVD-ROM drive encountered format-defined end-of-data block (e.g. attempt to read a audio track)
9h	Vendor Specific	Not used.
Ah	Copy Aborted	Not used.
Bh	Aborted Command	Indicates that the drive aborted the command execution. The Host Computer may recover by issuing the command again.
Ch	Equal	Not used.
Dh	Volume Overflow	Not used.
Eh	Miscompare	Not used.
Fh		Reserved.

Table 6.4: Sense Key

6.2 Error Information Code

ASC 12	ASCQ 13	DESCRIPTION
00h	00h	No Additional Sense Information
00h	06h	I/O Process Terminated
00h	11h	Audio Play Operation in Progress
00h	12h	Audio Play Operation Paused
00h	13h	Audio Play Operation Successfully Completed
00h	14h	Audio Play Operation Stopped Due to Error
00h	15h	No Current Audio Status to Return
02h	00h	No Seek Complete
04h	00h	Logical Unit Not Ready — Cause Not Reportable
04h	01h	Logical Unit Not Ready — In Progress of Becoming Ready
04h	02h	Logical Unit Not Ready — Initializing Command Required
04h	03h	Logical Unit Not Ready — Manual Intervention Required
05h	00h	Logical Unit does Not Respond to SELECTION
06h	00h	No Reference Position Found (media may be upside down)
07h	00h	Multiple Peripheral Devices Selected
08h	00h	Logical Unit Communication Failure
08h	01h	Logical Unit Communication Time-out
08h	02h	Logical Unit Communication Parity Error
09h	00h	Track Following Error
09h	01h	Tracking Servo Failure
09h	02h	Focus Servo Failure
09h	03h	Spindle Servo Failure
11h	00h	Unrecovered Read Error
11h	05h	L-EC Uncorrectable Error
11h	06h	CIRC Unrecovered Error
14h	00h	Recorded Entity Not Found
14h	01h	Record Not Found
15h	00h	Random Positioning Error
15h	01h	Mechanical Positioning Error
15h	02h	Positioning Error Detected by Read of Medium
17h	00h	Recovered Data with No Error Correction Applied
17h	01h	Recovered Data with Retries
17h	02h	Recovered Data with Positive Head Offset
17h	03h	Recovered Data with Negative Head Offset
17h	04h	Recovered Data with Retries and/or CIRC Applied
17h	05h	Recovered Data using Previous Sector ID
18h	00h	Recovered Data with Error Correction Applied
18h	01h	Recovered Data with Error Correction & Retries Applies
18h	02h	Recovered Data with — The Data was Auto-Reallocated
18h	03h	Recovered Data with CIRC
18h	04h	Recovered Data with L-EC
1Ah	00h	Parameter List Length Error
1Bh	00h	Synchronous Data Transfer Error

Table 6.5: ASC/ASCQ List (ASC:00h~29h)

ASC 12	ASCQ 13	DESCRIPTION
20h	00h	Invalid Command Operation Code
21h	00h	Logical Block Address Out of Range
24h	00h	Invalid Filed in CDB
25h	00h	Logical unit not supported
26h	00h	Invalid Filed in Parameter List
26h	01h	Parameter Not Supported
26h	02h	Parameter Value Invalid
28h	00h	Not Ready to Ready Transition, Medium may Have Changed
29h	00h	Power On, Reset or Hardware Reset Occurred
2Ah	00h	Parameters Changed
2Ah	01h	Mode Parameters Changed
2Ch	00h	Command Sequence Error
2Eh	00h	Insufficient Time for Operation
2Fh	00h	Command Cleared by Another Initiator
30h	00h	Incompatible Medium Installed
30h	01h	Cannot Read Medium – Unknown Format
30h	02h	Cannot Read Medium – Incompatible Format
39h	00h	Saving Parameters Not Supported
3Ah	00h	Medium Not Present
3Dh	00h	Invalid Bits in IDENTIFY Message
3Fh	00h	Logical Unit Operating Conditions Have Changed
3Fh	01h	Microcode Has Been Changed
40h	80h	Diagnostic Failure on Audio Processor LSI
40h	81h	Diagnostic Failure on Memories
40h	82h	Diagnostic Failure on ECC circuit
40h	83h	Diagnostic Failure on Gate-Array
40h	84h	Diagnostic Failure on Internal I/F Controller
43h	00h	Message Error
44h	00h	Internal Logical Unit Failure
45h	00h	Select or Reselect Failure
46h	00h	Unsuccessful Soft Reset
47h	00h	SCSI Parity Error
48h	00h	Initiator Detected Error Message Received
49h	00h	Invalid Message Error
4Ah	00h	Command Phase Error
4Bh	00h	Data Phase Error
4Ch	00h	Logical Unit Failed Self-configuration
4Eh	00h	Overlapped Commands Attempted
53h	00h	Media Load or Eject Failed
53h	02h	Medium Removal Prevented
55h	00h	System Resource Failure
57h	00h	Unable to Recover Table of Contents
5Ah	00h	Operator Request or State Change Input (Unspecified)
5Ah	01h	Operator Medium Removal Request
63h	00h	End of User Area Encountered on This Track
64h	00h	Illegal Mode for This Track or Incompatible Medium
6Fh	00h	Copy Protection Key Exchange Failure — Authentication Failure
6Fh	01h	Copy Protection Key Exchange Failure — KEY Not Present
6Fh	02h	Copy Protection Key Exchange Failure — KEY Not Established
6Fh	03h	Read of Scrambled Sector without authentication
6Fh	04h	Media Region Code is Mismatched to Logical Unit Region
6Fh	05h	Drive Region Must be Permanent / Region Reset Count Error
B9h	00h	Audio Play Not in Progress
BFh	00h	Loss of Streaming

Table 6.6: ASC/ASCQ List (ASC:2Ah~6Fh)