

## Network Scan Server

# EPSON Network Image Express Card User's Guide

---

All rights reserved. No part of this publication may be reproduced, stored in a retrieval system, or transmitted in any form or by any means, electronic, mechanical, photocopying, recording, or otherwise, without the prior written permission of SEIKO EPSON CORPORATION. No patent liability is assumed with respect to the use of the information contained herein. Neither is any liability assumed for damages resulting from the use of the information contained herein.

Neither SEIKO EPSON CORPORATION nor its affiliates shall be liable to the purchaser of this product or third parties for damages, losses, costs, or expenses incurred by purchaser or third parties as a result of: accident, misuse, or abuse of this product or unauthorized modifications, repairs, or alterations to this product.

SEIKO EPSON CORPORATION and its affiliates shall not be liable against any damages or problems arising from the use of any options or any consumable products other than those designated as Original EPSON Products or EPSON Approved Products by SEIKO EPSON CORPORATION.

EPSON is a registered trademark of SEIKO EPSON CORPORATION.

IBM and PS/2 are registered trademarks of International Business Machines Corporation. Apple, Macintosh, Mac, iMac, and Power Macintosh are registered trademarks of Apple Computer, Inc.

Microsoft and Windows are registered trademarks of Microsoft Corporation in the United States of America and other countries.

This product includes software developed by the University of California, Berkeley, and its contributors.

**General Notice:** Other product names used herein are for identification purposes only and may be trademarks of their respective companies.

Copyright © 2003 by SEIKO EPSON CORPORATION, Nagano, Japan.

## **FCC Compliance Statement For United States Users**

This device complies with Part 15 of FCC Rules. Operation is subject to the following two conditions: (1) this device may not cause harmful interference, and (2) this device must accept any interference received, including interference that may cause undesired operation.

This equipment has been tested and found to comply with the limits for a Class B digital device, pursuant to Part 15 of the FCC Rules. These limits are designed to provide reasonable protection against harmful interference in a residential installation. This equipment generates, uses and can radiate radio frequency energy and, if not installed and used in accordance with the instructions, may cause harmful interference to radio or television reception. However, there is no guarantee that interference will not occur in a particular installation. If this equipment does cause interference to radio and television reception, which can be determined by turning the equipment off and on, the user is encouraged to try to correct the interference by one or more of the following measures.

- Reorient or relocate the receiving antenna
- Increase the separation between the equipment and receiver
- Connect the equipment into an outlet on a circuit different from that to which the receiver is connected
- Consult the dealer or an experienced radio/TV technician for help.

### **WARNING**

The connection of a non-shielded equipment interface cable to this equipment will invalidate the FCC Certification of this device and may cause interference levels which exceed the limits established by the FCC for this equipment. It is the responsibility of the user to obtain and use a shielded equipment interface cable with this device. If this equipment has more than one interface connector, do not leave cables connected to unused interfaces.

Changes or modifications not expressly approved by the manufacturer could void the user's authority to operate the equipment.

### **For Canadian Users**

This Class B digital apparatus complies with Canadian ICES-003.

Cet appareil numérique de la classe B est conforme à la norme NMB-003 du Canada.

### **For European Users**

This product conforms to CE marking requirements in accordance with EC Directive 89/336/EEC.

## DECLARATION of CONFORMITY

According to 47CFR, Part 2 and 15 for Class B Personal Computers and Peripherals; and/or CPU Boards and Power Supplies used with Class B Personal Computers:

We: EPSON AMERICA, INC.

Located at: MS 6-43  
3840 Kilroy Airport Way  
Long Beach, CA 90806-2469  
Telephone: (562)290-5254

Declare under sole responsibility that the product identified herein, complies with 47CFR Part 2 and 15 of the FCC rules as a Class B digital device. Each product marketed, is identical to the representative unit tested and found to be compliant with the standards. Records maintained continue to reflect the equipment being produced can be expected to be within the variation accepted, due to quantity production and testing on a statistical basis as required by 47CFR §2.909 Operation is subject to the following two conditions: (1) this device may not cause harmful interference, and (2) this device must accept any interference received, including interference that may cause undesired operation.

Trade Name: EPSON

Type of Product: Network Scan Server

Model: EU-81

---

# Contents

## ***Safety Instructions***

---

Important Safety Instructions . . . . .	6
Warnings, Cautions, and Notes . . . . .	6

## ***Chapter 1 Getting to Know Your Network Image Express Card***

---

Package Contents . . . . .	8
Operating Environment . . . . .	9
Features . . . . .	10
Physical Description . . . . .	11
About the Software . . . . .	12

## ***Chapter 2 Setting Up the Network Image Express Card***

---

Connecting the Network Image Express Card on a Network . . . . .	14
Installing EpsonNet WinAssist/MacAssist . . . . .	16
For Windows . . . . .	16
For Macintosh . . . . .	17
Setting an IP Address Using EpsonNet WinAssist . . . . .	18
About password . . . . .	23
Using EpsonNet WinAssist EasySetup . . . . .	24
Setting an IP Address Using EpsonNet MacAssist . . . . .	27
About Password . . . . .	32
Using EpsonNet MacAssist EasySetup . . . . .	33
Setting an IP Address Using EpsonNet WebAssist . . . . .	36
Supported Web browser . . . . .	36
About Web browser setting . . . . .	37
Using EpsonNet WebAssist . . . . .	37
Setting an IP Address Using the arp Command . . . . .	41

---

**Chapter 3 Scanning an Image**

---

Preparing for Scanning at the Client PC .....	44
Scanning an Image .....	44

---

**Chapter 4 Troubleshooting**

---

Problems and Solutions .....	46
Restoring Factory Default Settings .....	48
Setting the Interface Mode .....	49
Uninstalling Software .....	51
Uninstalling EpsonNet WinAssist .....	51
Uninstalling EpsonNet MacAssist .....	52

---

**Appendix A Technical Specifications**

---

Network Image Express Card .....	54
Environmental .....	55
Safety Approvals .....	55

---

**Index**

---

---

# Safety Instructions

---

## Important Safety Instructions

Read all these instructions and save them for later reference. Follow all warnings and instructions marked on the EPSON Network Image Express Card.

- ❑ Do not spill liquid onto the Network Image Express Card.
- ❑ Do not place the Network Image Express Card on an unstable surface, or near a radiator or heat source.
- ❑ Avoid using outlets on the same circuit as photocopiers or air control systems that regularly switch on and off.
- ❑ Except as specifically explained in this *User's Guide*, do not attempt to service the Network Image Express Card yourself.

---

## Warnings, Cautions, and Notes



*Warnings must be followed carefully to avoid bodily injury.*



*Cautions must be observed to avoid damage to your equipment.*

*Notes contain important information and useful tips on the operation of your product.*

---

# ***Getting to Know Your Network Image Express Card***

Package Contents . . . . .	8
Operating Environment . . . . .	9
Features . . . . .	10
Physical Description . . . . .	11
About the Software . . . . .	12

---

## Package Contents

Your Network Image Express Card package includes:

- ❑ Network Image Express Card (the utility EpsonNet WebAssist is pre-installed)
- ❑ The Software CD-ROM including:
  - EpsonNet WinAssist
  - EpsonNet MacAssist
- ❑ User's Guide

**Note:**

*You need to supply items such as an EPSON scanner with an interface slot and an Ethernet cable (Category 5 shielded twisted-pair cable).*

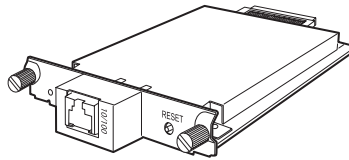

Network Image Express Card



Software CD-ROM

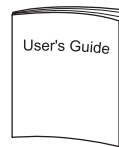

User's Guide



## Operating Environment

The Network Image Express Card supports the following environments.

### Windows

Operating system	Windows <sup>®</sup> XP, Me, 98, 2000, and Windows NT 4.0
Protocol	TCP/IP

### Macintosh

Operating system	Mac <sup>®</sup> OS 8.6 to 9.x, Mac OS X 10.2 or later
Protocol	TCP/IP

### Supported EPSON Scan

Use EPSON Scan 1.1 or later shipped with your scanner. If you have EPSON TWAIN Pro Network, EPSON TWAIN HS Network, or EPSON Scan 1.0, contact the dealer in your country to get the latest version of the software.

### Supported EPSON scanner

The Network Image Express Card supports the following EPSON scanners (as of March, 2003).

- Expression 1680/1640XL
- GT-30000/15000

**Note:**

*Future scanners with an interface slot are planned to be supported.*

---

## Features

The EPSON Network Image Express Card enables an EPSON scanner supporting EPSON Scan to become shareable on a network. With the Network Image Express Card, support for 10Base full/half duplex and 100Base full/half duplex, any clients (Windows or Macintosh) with EPSON Scan software installed can access the scanner at high speed.

The Network Image Express Card and EPSON Scan software work together to directly control all of the features of the scanner. As a result, the scanner can be shared and scanned images can be imported into any TWAIN-compliant application.

The illustration below shows how the EPSON scanner with the Network Image Express Card becomes shareable on a network. Your client PC can connect to the Network Image Express Card and import a scanned image from the scanner. When your PC disconnects, another client PC can access the Network Image Express Card for network scanning as well.

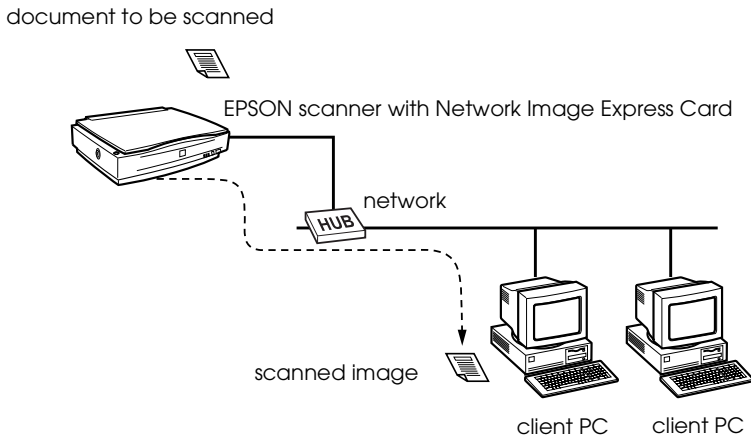

## Physical Description

The status lights provide you with important information about the operation of the Network Image Express Card.

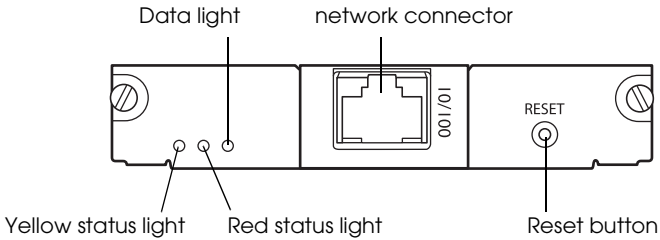

### Status and Data lights

The Network Image Express Card has three lights (two Status and one Data), which indicates the current operating status of the Network Image Express Card.

Status Light (Yellow)	Status Light (Red)	Data Light (Green)	Status
Off	On	On	Initializing
Off	Flashing alternately		Firmware update mode
Off	Flashing	On	Error status
On	Off	On	Ready (10M link)
On	Off	Flashing	Receiving data (10M link)
On	On	On	Ready (100M link)
On	On	Flashing	Receiving data (100M link)

### **Network connector**

The network connector accepts a 10Base-T or 100Base-TX network cable for connection to an Ethernet network. Be sure to use a Category 5 shielded twisted-pair cable to prevent malfunctions. The Network Image Express Card automatically selects either 10Base-T or 100Base-TX for the connection.

### **Reset button**

You can return the EPSON Network Image Express Card to its factory default settings. To do this, turn on the scanner while holding down the Reset button. Keep holding down the button for ten seconds or more; EPSON Network Image Express Card is returned to its factory default settings.

---

## ***About the Software***

- ❑ **EpsonNet WinAssist** is a Windows-based configuration utility for administrators that allows you to configure the Network Image Express Card for TCP/IP. See “Setting an IP Address Using EpsonNet WinAssist” on page 18.
- ❑ **EpsonNet MacAssist** is a Macintosh-based configuration utility for administrators that allows you to configure the Network Image Express Card for TCP/IP. See “Setting an IP Address Using EpsonNet MacAssist” on page 27.
- ❑ **EpsonNet WebAssist** is a web-based configuration utility that allows you to configure the Network Image Express Card for TCP/IP. You can start EpsonNet WebAssist from EpsonNet WinAssist or MacAssist, or by typing the IP address of the Network Image Express Card as the URL in your browser. See “Setting an IP Address Using EpsonNet WebAssist” on page 36.

---

## **Setting Up the Network Image Express Card**

Connecting the Network Image Express Card on a Network . . . .	14
Installing EpsonNet WinAssist/MacAssist . . . . .	16
For Windows . . . . .	16
For Macintosh . . . . .	17
Setting an IP Address Using EpsonNet WinAssist . . . . .	18
About password . . . . .	23
Using EpsonNet WinAssist EasySetup . . . . .	24
Setting an IP Address Using EpsonNet MacAssist . . . . .	27
About Password . . . . .	32
Using EpsonNet MacAssist EasySetup . . . . .	33
Setting an IP Address Using EpsonNet WebAssist . . . . .	36
Supported Web browser . . . . .	36
About Web browser setting . . . . .	37
Using EpsonNet WebAssist . . . . .	37
Setting an IP Address Using the arp Command . . . . .	41

---

## Connecting the Network Image Express Card on a Network

You need to install the Network Image Express Card in your scanner and connect it to your network. Follow the steps below for instructions.

1. Insert the Network Image Express Card in your scanner's optional interface slot and then tighten the screws.

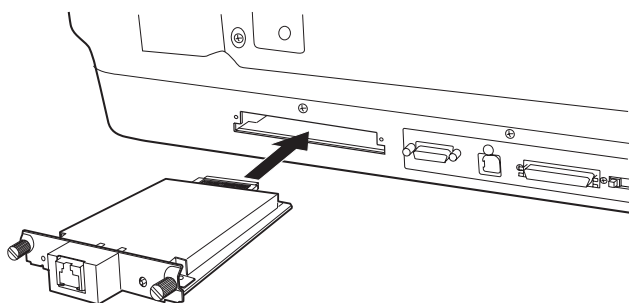

For detailed information on installing the Network Image Express Card, refer to the user's guide of the scanner.



**Caution:**

*Do not install or uninstall the Network Image Express Card from the scanner while the scanner is turned on; otherwise damage may occur.*

2. Initialize the Network Image Express Card. To do this, turn on the scanner while holding down the Reset button for 10 seconds until the red status light and green data light turn on.

**Note:**

*Be sure to initialize the Network Image Express Card when you insert or re-insert it in the scanner.*

3. Turn off the scanner.

4. Connect an Ethernet cable (Category 5 shielded twisted-pair cable) to the RJ-45 connector on the Network Image Express Card, and then connect its other end to the network.

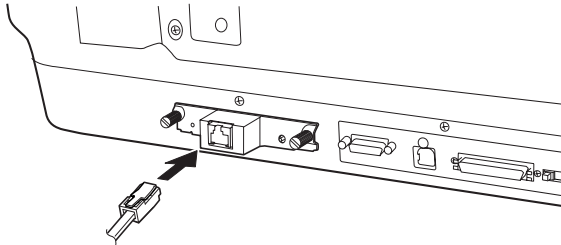

**Caution:**

- ❑ You must use a Category 5 shielded twisted-pair cable to connect the Network Image Express Card to prevent malfunction.
  - ❑ Do not connect or disconnect the network cable when the scanner is on.
  - ❑ Do not connect the Network Image Express Card and the computer directly. Be sure to use a HUB to connect the Network Image Express Card to the network.
5. Turn on the scanner.
  6. Check the lights on the Network Image Express Card. Initialization is in progress while the red status light and the green data light are on. When the yellow status light goes on, initialization is complete.

Now, you can configure the Network Image Express Card using EpsonNet WinAssist/MacAssist. Go to the next section “Installing EpsonNet WinAssist/MacAssist” on page 16.

---

## **Installing EpsonNet WinAssist/MacAssist**

You need to install EpsonNet WinAssist or MacAssist to configure the Network Image Express Card.

**Note:**

- ❑ *Be sure to use EpsonNet WinAssist/MacAssist included on the Software CD-ROM shipped with this product.*
- ❑ *Make sure the necessary components such as TCP/IP are installed on the computer, and network settings (such as the IP address, subnet mask, etc.) of the computer are set. See the online help on your operating system for instructions.*

### **For Windows**

#### **System requirements**

The following table lists the system requirements of EpsonNet WinAssist. You can configure the Network Image Express Card using EpsonNet WinAssist on the following operating systems.

Operating systems	Windows XP, Me, 98, 2000, and Windows NT 4.0 (with Service Pack 5.0 or higher)
Hard disk drive space	10 MB

#### **Installing EpsonNet WinAssist**

Follow the steps below to install EpsonNet WinAssist.

**Note:**

*If you add or delete protocols or services from your operating system after installing EpsonNet WinAssist, EpsonNet WinAssist may not work correctly. If this happens, uninstall EpsonNet WinAssist and then install it again.*



1. Insert the Software CD-ROM in the CD-ROM drive.
2. The EPSON Installation Program starts automatically.

If the Installer dialog box does not appear, double-click SETUP.EXE on the CD-ROM.

3. Select Install EpsonNet WinAssist, and then click .
4. Follow the on-screen instructions to complete the installation.

## For Macintosh

### System requirements

The following table lists the system requirements of EpsonNet MacAssist. You can configure the Network Image Express Card using EpsonNet MacAssist on the following operating systems.

Operating systems	Mac OS 8.6 to 9.x, Mac OS X 10.2 or later
Models	PowerPC Macintosh
Hard disk drive space	10 MB

### Installing EpsonNet MacAssist

Follow the steps below to install EpsonNet MacAssist.

1. Insert the Software CD-ROM in the CD-ROM drive.
2. Mac OS 8.6 to 9.x:  
Double-click the EPSON icon in the EPSON folder.

Mac OS X:

Double-click the Mac OS X folder in the EPSON folder, then double-click the EPSON icon.

**Note:**

*When the authentication dialog box to assign administrator privileges appears, enter the user name and password, and then click OK.*

3. The EPSON Installation Program starts automatically. Select Install EpsonNet MacAssist, and then click .
4. Follow the on-screen instructions to install the software.
5. Restart your computer.  
Mac OS 8.6 to 9.x:  
The MacAssistxxx folder, which contains the EpsonNet MacAssist icon and the EpsonNet MacAssist EasySetup icon, is created in the Applications folder.

Mac OS X:

The EpsonNet MacAssist OSX x.xx folder, which contains the EpsonNet MacAssist for OS X icon and the EpsonNetMacAssistOSXEasySet icon, is created in the Applications folder.

---

## **Setting an IP Address Using EpsonNet WinAssist**

This section explains how to use EpsonNet WinAssist to configure the Network Image Express Card.

**Note:**

- Check that the necessary protocols are installed on the computer.*
- Make sure the Network Image Express Card and the computer are connected to the same network.*
- Refer to the online help to learn about other functions of EpsonNet WinAssist. To access the online help, click the Help button.*

- ❑ *The sample screens are taken from Windows 98 using EpsonNet WinAssist. Other systems may differ in appearance, but the instructions are the same, except as noted.*
1. Turn on the scanner with the Network Image Express Card.
  2. Click Start, point to Programs or All Programs (Windows XP), and then select EpsonNet WinAssist V4. Click EpsonNet WinAssist to start it.
  3. Select the scanner you want to configure, and then click Configuration or double-click the scanner icon.

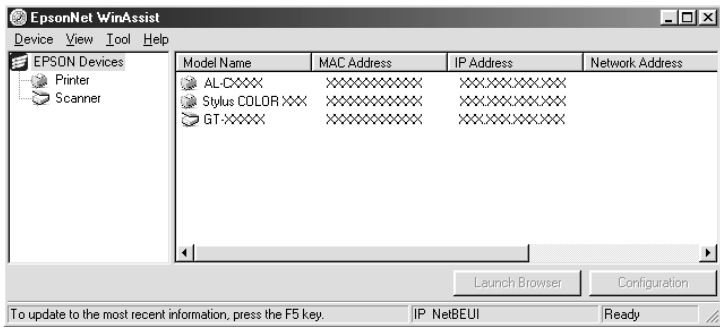

**Note:**

- ❑ *If the same scanner model name appears in the list, you can identify the scanners by checking their MAC address, which are found on the Network Image Express Card.*
- ❑ *You can search scanners in other segments by using Search Options from the Tool menu. See the online help for more information.*
- ❑ *The Launch Browser button can be used only if a valid IP address is assigned to the scanner.*
- ❑ *The default IP address “192.168.192.168” cannot be used on the network. Be sure to assign a valid IP address manually or by using the DHCP server.*

4. Click the TCP/IP tab.

**Note:**

*Refer to the online help to learn about other functions of EpsonNet WinAssist. To access the online help, click the Help button.*

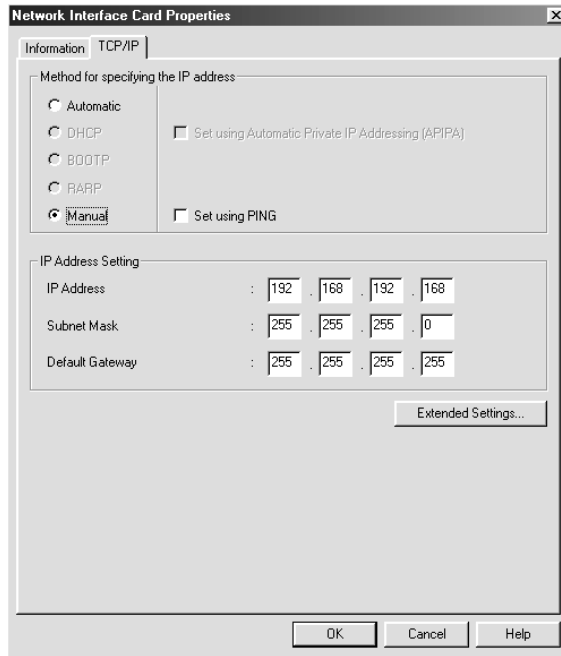

5. Select a method to specify the IP address. When you select Automatic, DHCP becomes available and assigns an IP address automatically. If you want to set the IP address manually, select Manual.

**Note:**

- The network administrator must confirm any changes made to the IP address settings.*

- ❑ *When Automatic is selected, DHCP becomes available. To use the DHCP server, make sure it is installed on your computer and correctly configured. See your operating system's online help for detailed instructions.*
  - ❑ *We recommend that you select Manual and enter an IP address. This is because if you select Automatic, the IP address of the Network Image Express Card changes every time you turn on the scanner so that you need to change the EPSON Scan setting accordingly.*
6. If you want to automatically get a private address between 169.254.1.1 and 169.254.254.254 when an IP address cannot be obtained by the DHCP server, select the Set using Automatic Private IP Addressing (APIPA) check box.
  7. When setting the IP address using the ping command, select the Set using PING check box. Do not select it when setting the IP address with EpsonNet WinAssist/MacAssist/WebAssist; this prevents any unexpected changes of the IP address.

**Note:**

*Be sure not to select the check box when not using ping; this prevents an unexpected change of the IP address.*

8. To assign the IP address manually, enter the IP address, the subnet mask, and the default gateway. Be sure the IP address does not conflict with any other device on the network.

**Note:**

*If there is a server or a router functioning as a gateway, enter the IP address of the server or the router for the gateway address. If there is no gateway, leave the default values there.*

9. Click the Extended Settings button if you want to change any extended settings, such as Host Name and Domain Name Setting; otherwise, go to step 13.

**Note:**  
*The DNS Server Address Settings and the Universal Plug and Play Settings are not supported.*

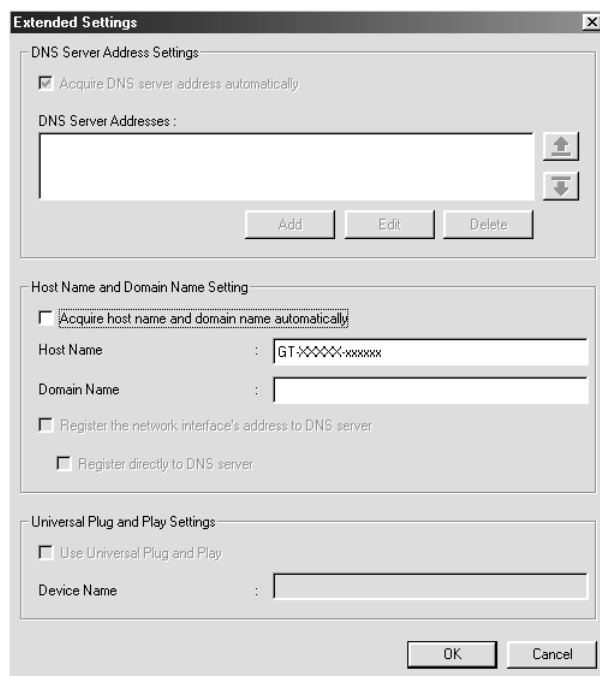

10. Select the Acquire host name and domain name automatically check box if you want to get the host name and the domain name using the DHCP server.

If you want to enter manually, enter the host name and the domain name in the text boxes.

11. Select the Register the network interface's address to DNS server check box if you want to register the host name and domain name on the DNS server through the DHCP server that supports Dynamic DNS.
12. After changing the settings, click OK.

13. In the TCP/IP dialog box, click OK. The Password dialog box appears.
14. Enter your password (up to 20 characters) and then click OK to save the settings. If you are entering a password for the first time, click Change and then set the password. See “About password” on page 23 for more information.

Follow the on-screen instructions. After the update is complete, refresh the configuration by selecting Refresh from the View menu.



**Caution:**

*Since it takes 2 or 3 minutes to send new settings to the Network Image Express Card, wait until an on-screen message appears to indicate that you can turn off your scanner. Do not turn off the scanner while the red status light and green data light are on.*

## **About password**

A password is required to configure the Network Image Express Card. When you click OK in the setting dialog box or click the Return to Default button, the Password dialog box appears.

1. To set a password or to change the current password, click Change. The Administrator password dialog box appears.
2. When you set a password for the first time, leave the Old Password box blank, and enter a password in the New Password box and the New Password (again) box (up to 20 characters). Then click OK. Passwords are case sensitive.

**Note:**

- ❑ *The same password is used for EpsonNet WinAssist, MacAssist, and WebAssist.*

- ❑ *Since the new password becomes effective after the data is sent to the Network Image Express Card, enter the old password immediately after changing the password.*
- ❑ *If you forget your password, you need to initialize the Network Image Express Card. See “Restoring Factory Default Settings” on page 48 for instructions.*

## **Using EpsonNet WinAssist EasySetup**

You can also use EpsonNet WinAssist EasySetup to easily configure the Network Image Express Card ready for TCP/IP within a short time.

### **Note:**

- ❑ *The computer to use for the following steps must be in the same segment as the Network Image Express Card.*
- ❑ *When you assign an IP address manually, we recommend you use EpsonNet WinAssist to set the subnet mask and the default gateway.*
- ❑ *If EpsonNet WinAssist is installed on your computer, you can also run EpsonNet WinAssist EasySetup from the Start menu. Click Start, point to Programs or All Programs (Windows XP), and then select EpsonNet WinAssist V4. Click EpsonNet EasySetup to start it. Then go to step 5 below.*

Follow the steps below to configure the Network Image Express Card using EpsonNet WinAssist EasySetup.

1. Turn on the scanner with the Network Image Express Card.
2. Insert the Software CD-ROM in the CD-ROM drive.
3. The EPSON Installation Program starts automatically.

If the Installer dialog box does not appear, double-click SETUP.EXE on the CD-ROM.



4. Select EpsonNet WinAssist Easy Setup, and then click .
5. In the EpsonNet WinAssist EasySetup dialog box, click Next.
6. Read the License Agreement and then click Next.
7. Select the target scanner and then click Next.

**Note:**

*If the same scanner model name appears on the list, you can identify the scanners by checking their MAC addresses, which are found on the Network Image Express Card.*

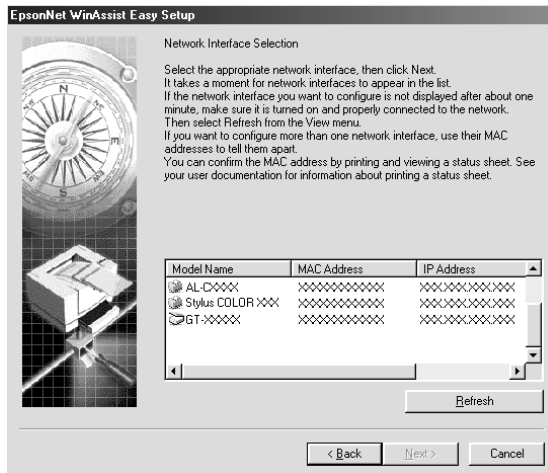

8. Select Automatic or Manual. If you select Automatic, DHCP becomes available and assigns an IP address automatically. If you select Manual, enter the IP address. Click Next.

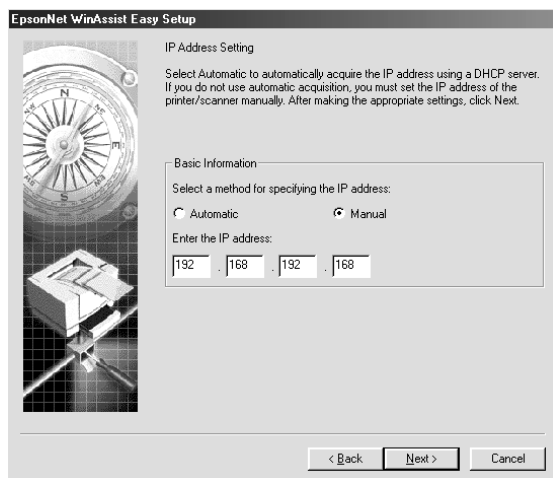

**Note:**

- ❑ *The default IP address “192.168.192.168” cannot be used on the network. Be sure to assign a valid IP address manually or by using the DHCP server.*
- ❑ *We recommend that you select Manual and enter an IP address. This is because if you select Automatic, the IP address of the Network Image Express Card changes every time you turn on the scanner so that you need to change the EPSON Scan setting accordingly.*
- ❑ *To use the DHCP server, make sure it is installed on your computer and configured correctly. See your operating system’s online help for detailed instructions.*

9. Check the settings and then click Send.  
If you have set a password, the Password dialog box appears.  
Enter your password (up to 20 characters) and then click OK.  
Follow the on-screen instructions.

**Caution:**

*It takes two or three minutes to send new settings to the Network Image Express Card. Do not turn off your scanner until an on-screen message prompts you to do so.*

---

## **Setting an IP Address Using EpsonNet MacAssist**

This section explains how to use EpsonNet MacAssist to configure the Network Image Express Card.

**Note:**

- ❑ *Make sure the scanner and the computer is connected to the same network.*
  - ❑ *Make sure that Ethernet is selected for Connect via in the TCP/IP control panel.*
1. Turn on the scanner with the Network Image Express Card.
  2. Mac OS 8.6 to 9.x:  
Double-click the EpsonNet MacAssist icon in the MacAssistxxx folder.

**Mac OS X:**

Double-click the EpsonNet MacAssist for OSX icon in the EpsonNet MacAssistOS X x.xx folder.

3. Select the scanner you want to configure from the list and click Configure.

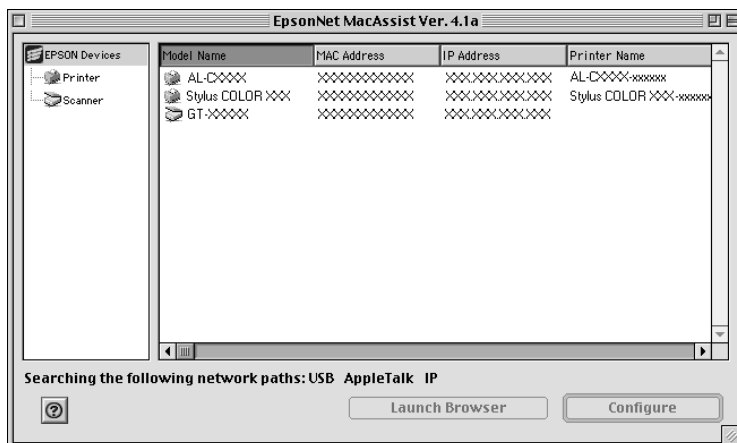

**Note:**

- ❑ *If the same scanner model name appears in the list, you can identify the scanners by checking their MAC addresses on the Network Image Express Card.*
- ❑ *You can search scanners in other zones just like computers by changing the zone setting. See the online help for more information.*
- ❑ *The Launch Browser button can be used only if a valid IP address is assigned to the scanner.*
- ❑ *The default IP address “192.168.192.168” cannot be used on the network. Be sure to assign a valid IP address manually or by using the DHCP server.*

4. Click the TCP/IP tab.

**Note:**

Refer to the online help to learn about other functions of EpsonNet WinAssist. To access the online help, click the help button.

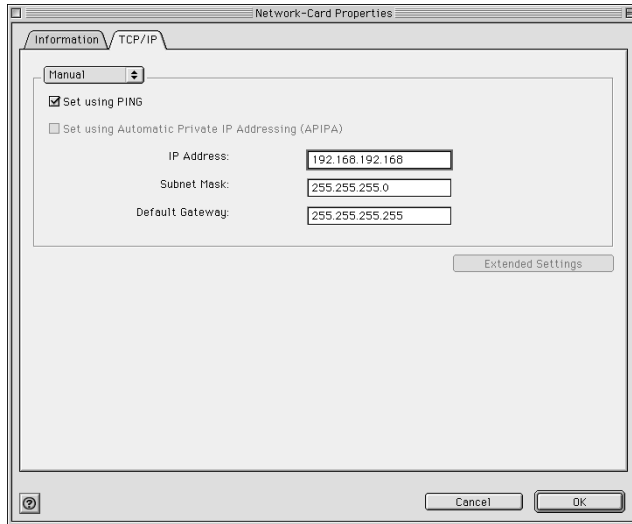

5. Select a method to specify the IP address. When you select Automatic, DHCP becomes available and assigns an IP address automatically. If you want to set the IP address manually, select Manual.

**Note:**

- The network administrator must confirm any changes made to the IP address settings.*
- When Automatic is selected, DHCP becomes available. To use the DHCP server, make sure it is installed on your computer and correctly configured. See your operating system's online help for detailed instructions.*
- We recommend that you select Manual and enter an IP address. This is because if you select Automatic, the IP address of the Network Image Express Card changes every time you turn on the scanner so that you need to change the EPSON Scan setting accordingly.*

6. When setting the IP address using the ping command, select the Set using PING check box. Do not select it when setting the IP address with EpsonNet WinAssist/MacAssist/WebAssist; this prevents any unexpected changes of the IP address.

**Note:**

*Be sure not to select the check box when not using ping; this prevents an unexpected change of the IP address.*

7. If you want to automatically get a private address between 169.254.1.1 and 169.254.254.254 when an IP address cannot be obtained by the DHCP server, select the Set using Automatic Private IP Addressing (APIPA) check box.
8. To assign the IP address manually, enter the IP address, the subnet mask, and the default gateway. Be sure the IP address does not conflict with any other device on the network.

**Note:**

*If there is a server or a router functioning as a gateway, enter the IP address of the server or the router for the gateway address. If there is no gateway, leave the default values there.*

9. Click the Extended Settings button if you want to change any extended settings, such as Host Name and Domain Name Setting; otherwise, go to step 13.

**Note:**

The DNS Server Address Settings and the Universal Plug and Play Settings are not supported.

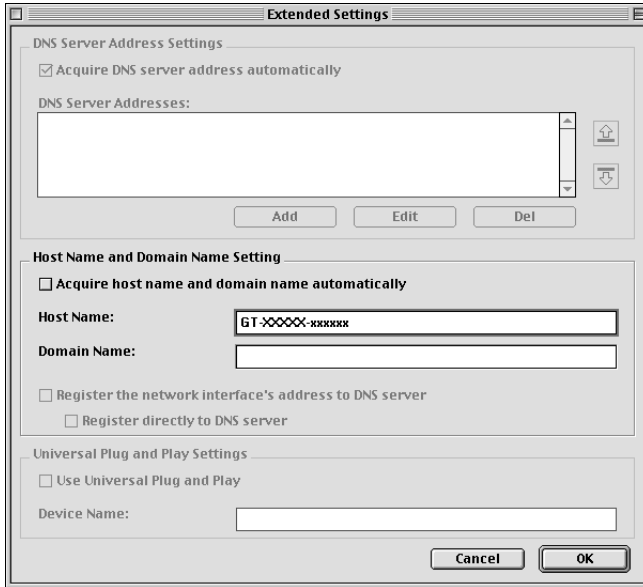

10. Select the Acquire host name and domain name automatically check box if you want to get the host name and the domain name using the DHCP server.

If you want to enter manually, enter the host name and the domain name in the text boxes.

11. Select the Register the network interface's address to DNS server check box if you want to register the host name and domain name on the DNS server through the DHCP server that supports Dynamic DNS.
12. After changing the settings, click OK.
13. In the TCP/IP dialog box, click OK. The Password dialog box appears.

14. Enter your password (up to 20 characters) and then click OK to save the settings. If you are entering a password for the first time, click Change Password and then set the password. For more information on passwords, see “About Password” on page 32.

Follow the on-screen instructions. After the update is complete, refresh the configuration by selecting Refresh from the Device menu.



**Caution:**

*Since it takes 2 or 3 minutes to send new settings to the Network Image Express Card, wait until an on-screen message appears to indicate that you can turn off your scanner. Do not turn off the scanner while the red status light and green data light are on.*

## **About Password**

A password is required to configure the Network Image Express Card. When you click OK in the setting dialog box or click Return to Default, the Password dialog box appears.

1. To set the password or to change the current password, click Change Password. The Change Password dialog box appears.
2. When you set a password for the first time, leave the Current Password box blank, and enter a password in the New Password box and the New Password (again) box (up to 20 characters). Then click OK. Passwords are case sensitive.

**Note:**

- ❑ *The same password is used for EpsonNet WinAssist, MacAssist, and WebAssist.*



- ❑ *Since the new password takes effect after the data is sent to the Network Image Express Card, enter the old password immediately after changing the password.*
- ❑ *If you forget your password, you need to initialize the Network Image Express Card. See “Restoring Factory Default Settings” on page 48 for instructions.*

## **Using EpsonNet MacAssist EasySetup**

You can also use EpsonNet MacAssist EasySetup to easily configure the Network Image Express Card ready for TCP/IP within a short time.

### **Note:**

- ❑ *The computer to use for the following steps must be in the same segment as the Network Image Express Card.*
- ❑ *When you assign an IP address manually, we recommend you use EpsonNet MacAssist to set the subnet mask and the default gateway.*
- ❑ *If EpsonNet MacAssist is installed on your computer, you can also run EpsonNet MacAssist EasySetup from the EpsonNet MacAssist folder. Just double-click the EpsonNet MacAssist EasySetup icon (Mac OS 8.6 to 9.x) or the EpsonNetMacAssistOSXEasySet icon (Mac OS X) and go to step 5 below.*

Follow the steps below to configure the Network Image Express Card using EpsonNet MacAssist EasySetup.

1. Turn on the scanner with the Network Image Express Card.
2. Insert the Software CD-ROM in the CD-ROM drive.
3. Mac OS 8.6 to 9.x:  
Double-click the EPSON icon in the EPSON folder.

Mac OS X:

Double-click the Mac OS X folder in the EPSON folder, then double-click the EPSON icon.

**Note:**

*When the authentication dialog box to assign administrator privileges appears, enter the user name and password, and then click OK.*

4. The EPSON Installation Program starts automatically. Select EpsonNet MacAssist Easy Setup, and then click .
5. Click Next.
6. Read the License Agreement and then click Next.
7. Select the target scanner and then click Next.

**Note:**

*If the same scanner model name appears on the list, you can identify the scanners by checking their MAC addresses, which are found on the Network Image Express Card.*

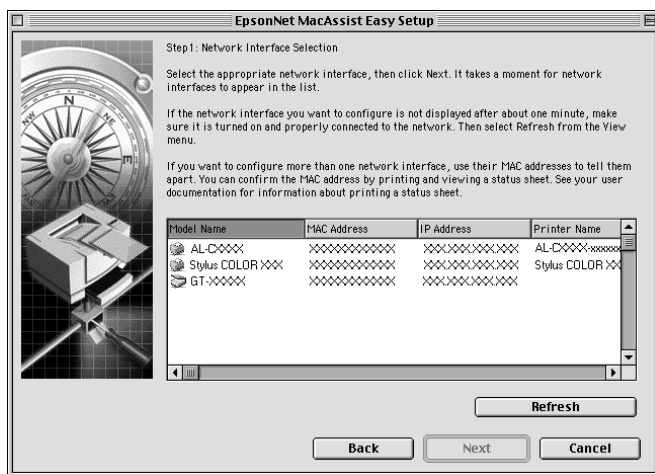

8. Select a method for specifying the IP address. If you select Automatic, DHCP becomes available and assigns an IP address automatically. If you select Manual, enter the IP address. Click Next.



**Note:**

- ❑ *The default IP address “192.168.192.168” cannot be used on the network. Be sure to assign a valid IP address manually or by using the DHCP server.*
- ❑ *We recommend that you select Manual and enter an IP address. This is because if you select Automatic, the IP address of the Network Image Express Card changes every time you turn on the scanner so that you need to change the EPSON Scan setting accordingly.*
- ❑ *To use the DHCP server, make sure it is installed on your computer and configured correctly. See your operating system’s online help for detailed instructions.*

9. Check the settings and then click Send.  
If you have set a password, the Password dialog box appears.  
Enter your password (up to 20 characters) and then click OK.  
Follow the on-screen instructions.



**Caution:**

*It takes two or three minutes to send new settings to the Network Image Express Card. Do not turn off your printer until an on-screen message prompts you to do so.*

---

## **Setting an IP Address Using EpsonNet WebAssist**

EpsonNet WebAssist is a web-based configuration application which allows you to configure the Network Image Express Card for TCP/IP. You can use EpsonNet WebAssist to change the settings and get information about the Network Image Express Card.

### **Supported Web browser**

- Microsoft Internet Explorer version 4.0 or later
- Netscape Communicator version 4.0 or later
- Netscape Navigator version 3.02 or later

**Note for Windows NT 4.0 users:**

*If you have not yet upgraded with Windows NT Service Pack 3, install the Windows NT Service Pack before installing Microsoft Internet Explorer.*

## About Web browser setting

When running EpsonNet WebAssist, be sure not to use a proxy server to access the Internet. If the Access the Internet using a proxy server check box is selected, you cannot use EpsonNet WebAssist. Use the following steps to clear the Access the Internet using a proxy server check box.

1. Right-click the Internet Explorer icon on the desktop, and then select Properties.
2. Click the Connection tab.
3. Clear the Access the Internet using a proxy server check box.

## Using EpsonNet WebAssist

### Note:

- A web browser must be installed on your computer.*
- There are some restrictions on the characters you can use depending on your browser. For details, see your browser or OS documentation.*
- TCP/IP must be correctly set up for the client PC and the Network Image Express Card.*
- The valid IP address needs to be set in advance. (The valid IP address means that communication with the client PC can be performed at that address.)*

1. Turn on the scanner with the Network Image Express Card.
2. Run EpsonNet WebAssist using one of the following ways:
  - ❑ Run EpsonNet WinAssist or EpsonNet MacAssist. Select the scanner you want to configure from the list and then click the Launch Browser button.
  - ❑ Open your browser, and then type in the IP address of the Network Image Express Card directly.

**http://IP address of Network Image Express Card/**

*Example: **http://192.168.100.201/***

3. The following screen appears.

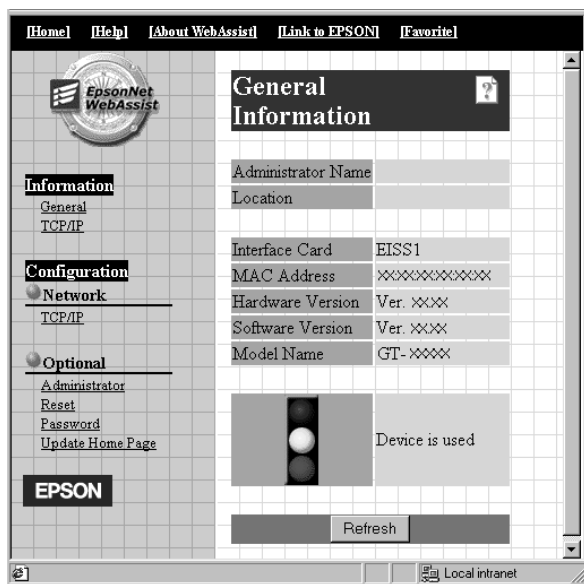

- Click TCP/IP under Network on the Configuration menu. The TCP/IP setting screen appears.

The screenshot shows the EpsonNet WebAssist interface for configuring TCP/IP settings. The left sidebar contains a navigation menu with sections: Information (General, TCP/IP), Configuration (Network, TCP/IP), and Optional (Administrator, Reset, Password, Update Home Page). The main content area is titled "TCP/IP" and is divided into several sections:

- IP Address Setting:**
  - Get IP Address: Manual (dropdown)
  - IP Address: xxx.xxx.xxx.xxx
  - Subnet Mask: xxx.xxx.xxx.0
  - Default Gateway: xxx.xxx.xxx.xxx
- Set using Automatic Private IP Addressing (APIPA):** Disable (dropdown)
- Set using PING:** Disable (dropdown)
- Host Name and Domain Name Setting:**
  - Setting Method: Manual (dropdown)
  - Host Name: GT-xxxxx-xxxxx
  - Domain Name: [empty field]
  - Request DNS dynamic updates via DHCP server: Disable (dropdown)

A SUBMIT button is located at the bottom of the form. The status bar at the bottom right indicates "Local intranet".

- Select the "Get IP Address" method. When you select Auto, DHCP becomes available and assigns an IP address automatically. If you want to set the IP address manually, select Manual.

**Note:**

- ❑ The network administrator must confirm any changes made to the IP address settings.
- ❑ When Auto is selected, DHCP becomes available. To use the DHCP server, make sure it is installed on your computer and correctly configured. See your operating system's online help for detailed instructions.

- ❑ *If Set using Automatic Private IP Addressing (APIPA) is enabled, a private IP address is automatically assigned to the Network Image Express Card even when there are no DHCP servers on your system or your network.*
  - ❑ *We recommend that you select Manual and enter an IP address. This is because if you select Auto, the IP address of the Network Image Express Card changes every time you turn on the scanner so that you need to change the EPSON Scan setting accordingly.*
6. To assign the IP address manually, enter the IP address, the subnet mask, and the default gateway. Be sure the IP address does not conflict with any other device on the network.

**Note:**

*If there is a server or a router functioning as a gateway, enter the IP address of the server or the router for the gateway address. If there is no gateway, leave the default values there.*

7. If you want to get a private address between 169.254.1.1 and 169.254.254.254 automatically when an IP address cannot be obtained by the DHCP server, select Enable for Set using Automatic Private IP Addressing (APIPA).
8. When setting the IP address using the ping command, select Enable for Set using PING. Select Disable when setting the IP address with EpsonNet WinAssist/MacAssist/WebAssist; this prevents any unexpected change of the IP address.

**Note:**

*Be sure to select Disable when not using ping; this prevents an unexpected change of the IP address.*

9. Select Manual or DHCP for Setting Method. You can select DHCP only if you have selected Auto for the Get IP Address method in step 5.
10. Enter the host name and the domain name.



11. Select Enable or Disable for Request DNS dynamic updates via DHCP server.
12. Click SUBMIT and enter the password to update the settings. The same password is required for EpsonNet WinAssist, MacAssist, and WebAssist.

**Note:**

*If you have set the Administrator Name in the Administrator screen, enter the administrator name for the user name.*

13. If the message "Configuration change is complete!" appears on your screen, the update is complete. Do not exit the Web browser and do not send a job to the Network Image Express Card until this message appears. Follow the on-screen instructions to reset the Network Image Express Card.

**Note:**

- Since the new IP address becomes available after the Network Image Express Card is reset, you need to restart EpsonNet WebAssist by entering the new IP address.*
- Only changes on the page where you press the SUBMIT button take effect.*
- Refer to the online help to learn about other functions of EpsonNet WebAssist. To access the online help, click Help on the Index.*

---

## **Setting an IP Address Using the arp Command**

For Windows XP, Me, 98, 2000, and NT 4.0, you can use the arp and ping commands to set the IP address of the Network Image Express Card. Make sure the TCP/IP protocol is correctly installed on the Windows system. The Network Image Express Card and the host must be in the same segment.

Before you start, obtain the following information:

- ❑ A valid IP address for the Network Image Express Card. Ask your network administrator for an IP address which will not cause conflict with any other device on the network. If you are the network administrator, choose an address within the subnet which will not cause conflict with any other device.
- ❑ The MAC (Ethernet hardware) address of the Network Image Express Card. This is a unique number for your Network Image Express Card which is different from the hardware serial number of the Network Image Express Card. You can find out the MAC address on the Network Image Express Card.

To set the new IP address, use the `arp` command with the `-s` flag (create ARP entry).

**Note:**

*The following example assumes the MAC address is 00:00:48:93:00:00 (hexadecimal) and IP address is 192.135.223.6 (decimal). In real cases, substitute your values for these addresses when entering the commands.*

Follow the steps below to assign an IP address using the `arp` command:

1. From the command line, type:  
Example: `arp -s 192.135.223.6 00-00-48-93-00-00`
2. Check the new IP address by “pinging” it:  
Example: `ping 192.135.223.6`
3. The Network Image Express Card should now respond to the ping. If it does not, you may have incorrectly typed the MAC address or the IP address in the `arp -s` command. Check and try again. If the problem still continues, re-connect the Network Image Express Card and start over again.



**Caution:**

*Do not turn off the scanner while the red status light and green data light are on; otherwise damage may occur.*

---

**Scanning an Image**

Preparing for Scanning at the Client PC .....44

Scanning an Image .....44

---

## **Preparing for Scanning at the Client PC**

After setting up the Network Image Express Card, install EPSON Scan on your client PC. Specify the IP address of the Network Image Express Card using EPSON Scan, before the clients use the scanner with the card to scan documents in the networked environment. Refer to the user's guide of the scanner to learn how to install the software and specify the IP address.

Use EPSON Scan 1.1 or later shipped with your scanner. If you have EPSON TWAIN Pro Network, EPSON TWAIN HS Network, or EPSON Scan 1.0, contact the dealer in your country to get the latest version of the software.

**Note:**

*If you are using an older version of EPSON Scan, you need to uninstall it before installing the latest version. Refer to the user's guide of the scanner to learn how to uninstall the software.*

---

## **Scanning an Image**

Network scanning requires that all of the devices (the scanner with the Network Image Express Card and the client PC) be turned on, and the EPSON Scan be running.

To scan a document, click the **SCAN** button in the EPSON Scan dialog box. Refer to the user's guide of the scanner to learn how to use EPSON Scan.

## **Troubleshooting**

---

Problems and Solutions .....	46
Restoring Factory Default Settings .....	48
Setting the Interface Mode .....	49
Uninstalling Software .....	51
Uninstalling EpsonNet WinAssist .....	51
Uninstalling EpsonNet MacAssist .....	52

---

## ***Problems and Solutions***

This section provides solutions to problems you may have.

Refer to the “Troubleshooting” section in the user’s guide of the scanner if you have problems with the software.

The online help also provides versatile tips and other information helpful for problem-solving.

If you cannot solve a problem after reading and following the information in this chapter, contact your dealer or a qualified customer support person for assistance.

### **Unable to start EpsonNet WinAssist.**

<b>Cause</b>	<b>What to do</b>
You have added or deleted protocols after installing EpsonNet WinAssist.	Uninstall EpsonNet WinAssist and then reinstall it. See “Uninstalling Software” on page 51 and “Installing EpsonNet WinAssist/MacAssist” on page 16.

### **The message “EpsonNet WinAssist cannot be used because no network is installed.” appears when you start EpsonNet WinAssist.**

<b>Cause</b>	<b>What to do</b>
The TCP/IP protocol is not installed on the computer.	Install the TCP/IP protocol on your computer.
TCP/IP is installed on the computer, but its IP address is not set correctly.	Set the IP address for the computer correctly.

### The red status light is on while the data light is off.

Cause	What to do
A fatal error occurs, or the Network Image Express Card is malfunctioning.	When an error occurs, turn off the scanner and then turn it back on again. If this does not correct the problem, consult your dealer.

### The scanner does not scan.

Cause	What to do
The scanner is off.	Make sure the scanner is turned on. Refer to the user's guide of the scanner to learn how to turn on the scanner.
The Network Image Express Card is not connected properly.	Turn off the scanner and make sure the Network Image Express Card is properly installed in your scanner and connected to the network. See "Connecting the Network Image Express Card on a Network" on page 14 for details.
The scanner is not supported by the Network Image Express Card.	Make sure the supported scanner is connected to the Network Image Express Card. See "Network Image Express Card" on page 54 for more details.
The interface mode of the Network Image Express Card is not appropriate for your network environment.	Check the interface mode of the HUB, and change the jumper setting of the Network Image Express Card. See "Setting the Interface Mode" on page 49.
The software version is not proper.	Make sure you install EPSON Scan 1.1 or later on the client PC.

**The scanner does not appear in the list of EpsonNet WinAssist or MacAssist.**

Cause	What to do
You may be using the older version of EpsonNet WinAssist or MacAssist.	Use EpsonNet WinAssist or MacAssist Version 4.1 or higher that is included on the Software CD-ROM shipped with the Network Image Express Card.

---

## ***Restoring Factory Default Settings***

If required, you can return the EPSON Network Image Express Card to its factory default settings. When you restore the default settings, all your current settings will be lost. You will need to re-assign the IP address as described in Chapter 2, “Setting Up the Network Image Express Card.”

**Note:**

*You cannot use the default IP address “192.168.192.168” on the network. You must assign a valid IP address to use it on your network.*

The defaults of the Network Image Express Card are as follows:

TCP/IP:  
Get IP address: Manual  
IP Address: 192.168.192.168  
Subnet Mask: 255.255.255.0  
Default Gateway: 255.255.255.255  
Automatic Private IP Addressing: OFF  
Set by PING: ON  
Dynamic DNS request: OFF  
Use Host name acquired from DHCP: OFF



1. Make sure that the scanner with the Network Image Express Card is turned off.
2. While holding down the Reset button, turn on the scanner.
3. Keep holding down the Reset button for 10 seconds or more until the red status light and green data light turn on. The factory default settings are restored.



**Caution:**

*Do not turn off the scanner while the red status light and green data light are on; otherwise the scanner may become damaged.*

---

## **Setting the Interface Mode**

Jumpers are located on the board of Network Image Express Card. By default, the Network Image Express Card automatically selects the interface mode.

If you want to manually set the interface mode, follow the steps below.

1. Turn off your scanner.
2. Pull out the Network Image Express Card from the scanner's interface slot, and place it on an insulator such as a sheet.
3. Use the following table to change the jumper settings.

**Note:**

Do not change the jumper other than the following table.

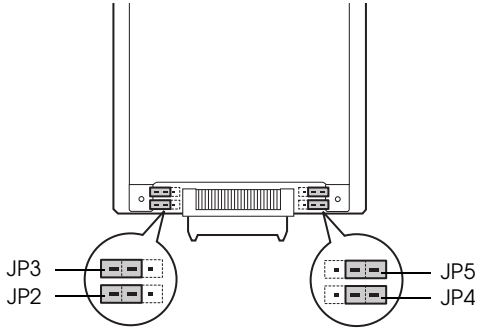

JP2	JP3	JP4	JP5	Mode
Open	Open	Open	Open	Auto-negotiation (10Half, 10Full, 100Half, 100Full) Factory default setting
Close	Open	Open	Open	100Base-TX Full Duplex
Close	Open	Open	Close	100Base-TX Half Duplex
Close	Open	Close	Open	10Base-T Full Duplex
Close	Open	Close	Close	10Base-T Half Duplex

For example, if you want to set to 10Base-T Full Duplex, pull out the jumper of JP2 and JP4, and put it over the two pins.

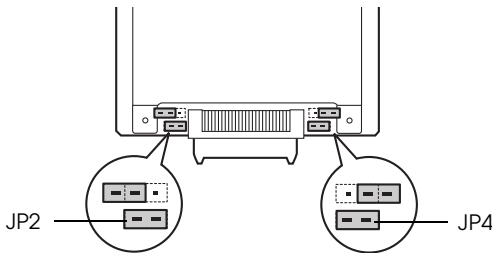

4. After changing the settings, make sure the scanner is turned off, and then insert the Network Image Express Card into the scanner's interface slot.
5. Turn on your scanner.

---

## ***Uninstalling Software***

### ***Uninstalling EpsonNet WinAssist***

#### *Windows Me/98/2000/NT 4.0*

1. Click Start, point to Settings, and then select Control Panel.
2. Double-click the Add/Remove Programs icon.
3. Select the utility you want to uninstall, and then click the Add/Remove button (Windows Me/98/NT 4.0) or the Change/Remove button (Windows 2000).
4. Follow the on-screen instructions to complete uninstallation.

#### *Windows XP*

1. Click Start, click Control Panel, and then click Add or Remove Programs.
2. Click the Change or Remove Programs icon.
3. Select the utility you want to uninstall, and then click the Change/Remove button.
4. Follow the on-screen instructions to complete uninstallation.

## ***Uninstalling EpsonNet MacAssist***

1. Insert the Software CD-ROM in the CD-ROM drive.
2. Mac OS 8.6 to 9.x:  
Double-click the EpsonNet MacAssist folder.  
  
Mac OS X:  
Double-click the Mac OS X folder, and then double-click the EpsonNet MacAssist folder.
3. Double-click the EpsonNet MacAssist Installer icon.
4. Click the Continue button.
5. In the License dialog box, read the License Agreement, and then click the Accept button.
6. Select Uninstall from the pull down menu.
7. Click the Uninstall button.
8. Follow the on-screen instructions to complete uninstallation.

***Note:***

*You can also uninstall EpsonNet MacAssist by dragging the MacAssistxxx folder (Mac OS 8.6 to 9.x) or the EpsonNet MacAssist OSX x.xx folder (Mac OS X) to the Trash.*

---

**Technical Specifications**

Network Image Express Card .....54  
Environmental .....55  
Safety Approvals .....55

---

## **Network Image Express Card**

Supported scanner: Expression 1680  
Expression 1640XL  
GT-30000  
GT-15000

Supported EPSON Scan: EPSON Scan (Win) Version 1.1 or later  
EPSON Scan (Mac) Version 1.1 or later

### Network

Cable interface: 10Base-T/100Base-TX  
Connector: RJ-45 connector  
Supported protocol: TCP/IP  
Rated Voltage: 5 V $\pm$ 5%, 24 V $\pm$ 10%  
Current: 5 V 190 mA, 24 V 50 mA  
Power: Approx. 2.2 W  
Light source: Status light (Yellow)  
Status light (Red)  
Data light (Green)  
Size: Width: 95 mm (3.8 inches)  
Depth: 160 mm (6.4 inches)  
Height: 20.6 mm (0.824 inches)  
Weight: Approx. 200 g

---

## Environmental

### Temperature:

Operation	5 to 35° C (41 to 95° F)
Storage	-25 to 60° C (-13 to 140° F)

### Humidity:

Operation	10 to 80%, without condensation
Storage	10 to 85%, without condensation

### Operating conditions:

Ordinary office or home conditions.  
Extreme dust should be avoided.  
Operation under direct sunlight or near a strong light source should be avoided.

### Note:

*Specifications are subject to change without notice.*

---

## Safety Approvals

### U.S. model:

EMC	FCC Part 15 Subpart B Class B CSA C108.8 Class B
-----	---

### European model:

EMC Directive 89/336/EEC	EN 55022 Class B EN 55024 EN 61000-3-2 EN 61000-3-3
--------------------------	--

### Australian model:

EMC	AS/NZS 3548 Class B
-----	---------------------

---

# Index

## **Numerics**

100Base-TX, 12

10Base-T, 12

## **A**

arp, 41

Automatic Private IP Addressing  
(APIPA), 21, 30, 40

## **D**

Default gateway, 21, 30, 40

## **E**

Environmental specifications, 55

EpsonNet

  MacAssist, 27

  MacAssist EasySetup, 33

  WebAssist, 36

  WinAssist, 18

  WinAssist EasySetup, 24

EPSON Scan, 9, 44

## **F**

Factory default settings, 48

## **I**

Important safety instructions, 6

Installation

  EpsonNet MacAssist, 17

  EpsonNet WinAssist, 16

IP address setting, 18, 27, 36, 41

## **J**

Jumper, 49

## **N**

Network, 54

Network connector, 12

## **P**

Password for

  EpsonNet MacAssist, 32

  EpsonNet WinAssist, 23

## **R**

Router, 21, 30, 40

## **S**

Specifications

  environmental, 55

  Interface card, 54

  Safety approvals, 55

Subnet mask, 21, 30, 40

## **T**

TCP/IP, 20, 28, 39, 41

## **U**

Uninstallation

  EpsonNet MacAssist, 52

  EpsonNet WinAssist, 51

Unpacking, 8