

The logo for Actiontec, featuring the brand name in a white, cursive-style font with a registered trademark symbol, set against a dark blue oval background with a silver border.

Actiontec[®]

54 Mbps

**Wireless
DSL Gateway**

Model #: GT701-WG

User Manual

Solutions for the Digital Life™

Table of Contents

1	Introduction	1
	Package Contents	1
	Minimum System Requirements	1
	Features	2
	Technical Support	5
2	Setting Up the Gateway	9
	Attention!	9
	Connecting a Computer to the Gateway	10
	Installing Phone Filters	27
	Setting Up the DSL Connection	34
3	Using Qwest DSL	41
	Connecting to the Internet	41
	Disconnecting from the Internet	41
4	Basic Setup	43
	Basic Setup	43
5	Setting Up Static IP Address	47
	Configuring for a Single Static IP Address	47
	Configuring for a Block of Static IP Addresses	51
6	Advanced Setup	57
	Accessing Advanced Setup	57
	WAN IP Address	58
	Wireless Settings	63
	Wireless MAC Authentication	67
	LAN IP Address	68
	DHCP Server	68
	Services Blocking	70
	Website Blocking	71
	Remote Management	72
	Port Forwarding	73
	DMZ Hosting	74
	Firewall	75
	Dynamic Routing	75
	NAT (Network Address Translation)	76
	Static Routing	76
	Status	77
7	Using Utilities	81
	Web Activity Log	81
	DSL Settings	82
	Restore Default Settings	83
	Upgrade Firmware	83

8	Setting Up a Network	85
	Ethernet	85
	USB	91
9	Troubleshooting	97
A	Reference	101
	Locating Computer Information	101
	Locating Windows Operating System Files	102
B	Static IP Address on the Computer	105
	Windows 98 SE	105
	Windows Me	108
	Windows 2000	111
	Windows XP	115
C	Computer Security	121
	Comparing DSL Service with a Dial-Up Modem	121
	Gateway Security	122
	Computer Security	122
	Electronic Security	123
D	Specifications	125
	General	125
	Wireless Operating Range	126
	LED Indicators	126
	Environmental	126
E	Glossary	127
F	Firewall Security Level Services Table	131
	High Security Level	131
	Medium Security Level	132
	Low Security Level	132
	Basic Security Level	132
	Service Acronym Definitions	133
G	Non-Windows System Setup	135
	Classic	135
	OS X	137
	Connecting to the ISP	138
	Notices	141
	Regulatory Compliance Notices	141
	Modifications	141
	Limited Warranty	143

Introduction

1

Thank you for purchasing the *Actiontec* 54 Mbps Wireless Gateway. The Gateway is the simplest way to connect computers to a high-speed broadband connection. This easy-to-use product is perfect for the office or small business. If you want to take your computing to the next level, the *Actiontec* 54 Mbps Wireless Gateway is sure to be one of the keys to your success.



Package Contents

- *Actiontec* 54 Mbps Wireless Gateway
- Power adapter
- Phone filters
- DSL cable
- Ethernet cable
- USB cable
- Installation CD-ROM
- Quick start guides

Minimum System Requirements

- Active DSL service
- Computer with an 10 Mbps or 10/100 Mbps Ethernet connection, or USB connection

- Microsoft Windows 98 Second Edition (SE), Windows Millennium Edition (Me), Windows NT 4.0, Windows 2000, Windows XP, Mac OS 7.1+, Mac OS 8.0+, Mac OS 9.0+, or Mac OS X+

 **Note:** USB LAN port is not supported with Microsoft Windows 95, Windows NT 4.0, and Mac OS.

- Internet Explorer 5.0 or higher (6.x recommended) or Netscape Navigator 4.0 or higher (4.7 recommended)
- TCP/IP network protocol installed on each computer

Features

This section contains a quick description of the Gateway's lights, ports, etc. The Gateway has several indicator lights (LEDs) on its front panel and a series of ports on its rear panel.

Front Panel

The front panel of the Gateway features six lights: Power, DSL, Internet, Ethernet, USB, and Wireless.

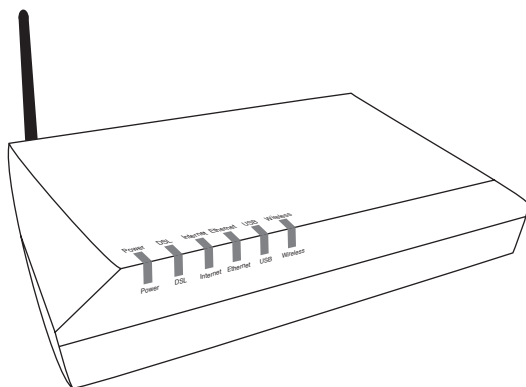

Power Light

The Power Light displays the Gateway's current status. If the Power Light glows steadily green, the Gateway is receiving power and fully operational. When the Power Light is rapidly flashing, the Gateway is initializing. If the Power Light is not illuminated when the power cord is plugged in, the Gateway has suffered a critical error and technical support should be contacted.

DSL Light

The DSL light illuminates when the Gateway is connected to a DSL line.

Internet Light

When the Internet Light glows steadily, the Gateway is connected to the DSL provider. When it flashes, the Gateway's built-in DSL modem is training for your DSL service.

Ethernet Light

The Ethernet light illuminates when the Gateway is connected via its Ethernet Port.

USB Light

The USB light illuminates when the Gateway is connected via its USB port.

Wireless Light

The Wireless light illuminates when the Gateway is connected wirelessly

Rear Panel

The rear panel of the Gateway contains eight ports (Ethernet [4], Line, Phone, USB, and Power), as well as a Reset switch.

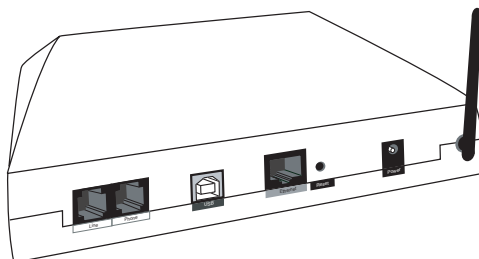

Line Port

Used to connect the Gateway to a DSL (Digital Subscriber Line) connection.

Phone Port

Used to connect a telephone to the Gateway.

USB Port

Used to connect a computer to the Gateway via USB cable.

Ethernet Port

Used to connect computers to the Gateway via Ethernet cable. The Ethernet port is a 10/100 Mbps auto-sensing ports, and either a straight-through or crossover Ethernet cable can be used when connecting to the port.

Reset Switch

Depressing the reset switch for one or two seconds will power cycle (similar to unplugging and then plugging in the Gateway's power cord) the Gateway. To restore the Gateway's factory default settings, depress and hold the Reset Switch for approximately 10 seconds. The reset process will start about 10 seconds after releasing the Reset Switch.

Power Port

Used to connect the Power Cord to the Gateway.



Warning: Do not unplug the power cord from the Gateway during the reset process. Doing so may result in permanent damage to the Gateway.

Technical Support

Self Help

To obtain answers to DSL configuration questions, visit the Qwest DSL *Actiontec* support page at this address:

<http://www.qwest.com/dsl/customerservice/Actiontecg701-wg.html>

A help page is also available on the main page of the *Actiontec* DSL Gateway Web interface. Enter

192.168.0.1

in the browser's address text box, and when the first screen appears, click **HELP**.

Basic Setup Support

If unable to access the Internet, look at the Internet light on the front of the DSL Gateway. If the light is **solid green**, call the ISP immediately. If it is **not solid green**, call Qwest at 1-800-247-7285.

Other Problems

Contact the ISP if experiencing problems with:

- DHCP addressing configuration
- Static IP addressing configuration
- Transparent bridging configuration

Contact Qwest at 1-800-247-7285 for:

- DSL service outage support and repair

- DSL service installation support



Note: Before attempting any of the above, make sure access to the Internet is available.

Advanced Feature Support

Qwest DSL technical support provides the following advanced feature support for the Actiontec DSL Gateway. Contact Qwest at 1-800-247-7285 for configuration assistance.

- Enabling Website Blocking
- Enabling VPN Pass-Through
- Enabling/Disabling NAT
- Firewall configuration
- Changing the LAN IP address of the DSL Gateway
- Enabling Services Blocking
- Enabling/Disabling DHCP
- VIP feature

These features are supported in the Gateway only. Implementation of the above features within the network (LAN) is not supported.

Wired/Wireless Upgrade

Wired and wireless upgrade installation support is available from Actiontec free of charge if the wired/wireless equipment was purchased from Actiontec. Contact Actiontec at 1-888-436-0675 for installation and configuration support information.

Networking (LAN) Support

If a wired/wireless network has been set up and support is needed in one of the following areas:

- LAN support of multiple computers and peripherals;
- Microsoft Windows Networking;

- Microsoft Internet Connection Sharing (ICS);
- Advanced LAN configuration with multiple computers;
- Non-Actiontec-provided network card/Ethernet cable installation, configuration, or troubleshooting;
- Commercial firewall software configuration;

contact the **Actiontec Pay For Support Center** at 1-888-825-9025. Actiontec networking support is provided for a fee of \$29.95 per incident. Other fee-based feature support includes:

- Port Forwarding (Static NAT)
- Static Routing
- MAC Address Cloning
- Third-party vendor wireless equipment configuration
- DMZ Hosting
- NAT Routes
- RIP (Dynamic Routing)

This support service does not include an on-site field technician.

To purchase Actiontec wireless cards and peripherals, visit the Actiontec Web site at www.actiontecstore.com/qwest

This page left intentionally blank.

Setting Up the Gateway

2

The instructions that follow parallel the steps contained in the *Actiontec* Installation Buddy™, which provides a visual guide to setting up the Gateway. It is recommended the user run the Installation Buddy first, before attempting any other procedures.

To set up the Gateway, it must be connected to a computer, and then configured. After connecting this first computer, other computers can be added to the network via USB, Ethernet, or wirelessly (see “Setting Up a Network” on page 63).

Attention!

Read the following two sections (Alarm System, Automatic Water Heater) before proceeding with any installation!

Alarm System

If your home or business has an alarm system, and if Qwest DSL shares the same phone line, you have special wiring needs. If you did not order a technician install at the time of sale, please contact your Security Alarm Provider or Qwest Sales as soon as possible to order and schedule your installation.

If your security alarm system is wired incorrectly, it may not be able to make a notification call when the alarm is triggered.

Professional wiring is required to ensure inter-operability. **Do not attempt the installation yourself!**

Qwest strongly recommends contacting your security organization for more information about your security alarm system before attempting to install Qwest DSL. Qwest also strongly recommends contacting your security organization after installing Qwest DSL to have them conduct a test of your alarm system.

Automatic Water Meter

Although most water companies do not utilize automatic water meters, some do. If you have an automatic water meter using the same phone line as your Qwest DSL service, you must install a DSL Phone Filter.

Contact your water company for help installing the DSL Phone Filter on your water meter, or if you are unsure whether your water meter uses your phone line.

Connecting a Computer to the Gateway

Connecting a computer to the Gateway for setup involves three basic steps: initial setup, plugging in the Gateway's power cord, and connecting the Gateway to the computer.

 **Note:** The following procedures are for U.S. installations only.

Connecting Via Ethernet

1. Insert the Installation CD in the CD-ROM drive of the computer. The Installation Buddy will start automatically. Wait until the following screen appears, read the on-screen instructions, then click **Next**.



2. Read the instructions, select **Initial Setup** by clicking on the appropriate check box, then click **Next**.



3. Select the appropriate modem payment option, then click **Next**.



4. Read the on-screen instructions regarding the terms and agreements of the rental contract, click in the white circle next to **I accept this agreement**, then click **Next**.

 **Note:** If “I purchased my modem from Qwest” was selected in step 3, go directly to step 5.

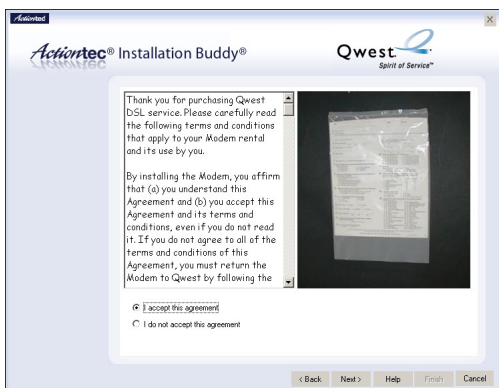

5. Click the check box next to **Ethernet (Recommended)**, then click **Next**.



6. Get the Welcome Letter (or ISP Worksheet) provided by the ISP. Click **Next**.

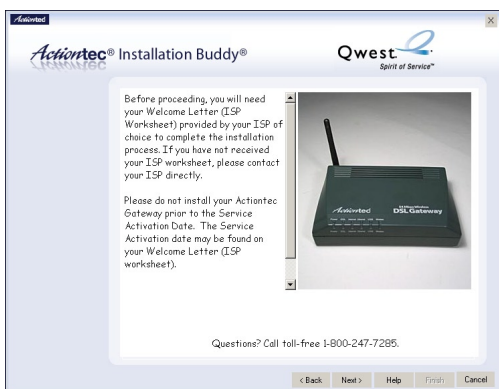

7. Read the on-screen information concerning home security alarms, then click **Next**.

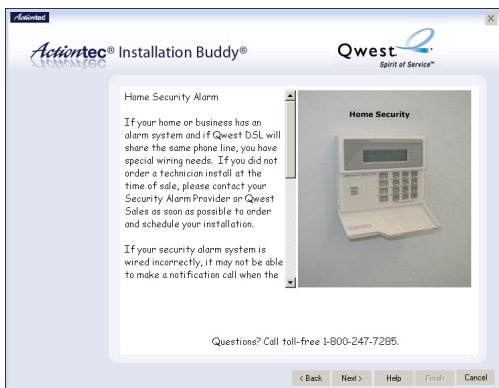

8. Make sure the items needed to connect the Gateway to the first computer on included in the kit, then click **Next**.

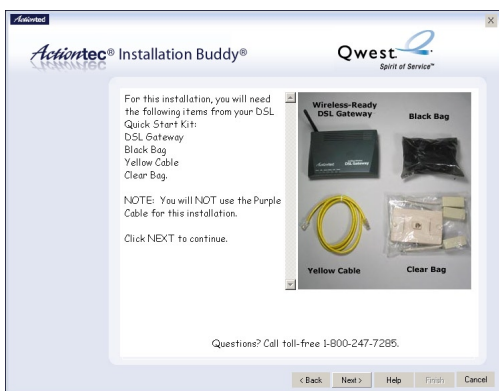

9. Get the Gateway from the kit, then click **Next**.



10. Get the **Power cord** from the black bag and plug the smaller end into the **black Power port** on the rear panel of the Gateway, then click **Next**.

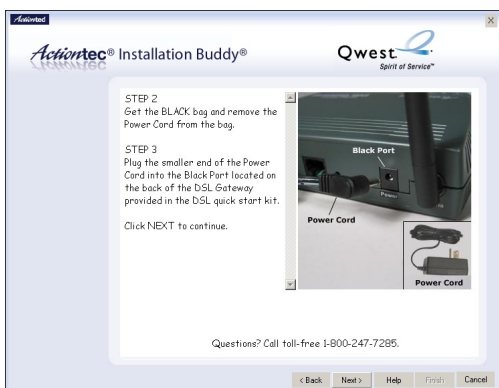

11. Plug the larger end of the **Power cord** into a **power outlet**, then click **Next**.



12. Confirm the **Power light** on the front of the Gateway **glows solid green**, then click **Next**.



13. Get the **yellow Ethernet cable** from the kit and plug one end into a **Yellow port** on the back of the Gateway, then click **Next**.

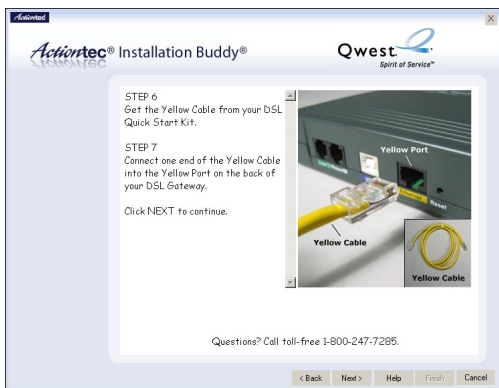

14. Plug the other end of the **yellow Ethernet cable** into an **Ethernet port** on the back of the computer. Click **Next**.



 **Note:** An Ethernet port looks similar to a phone jack, but is slightly larger.

15. Make sure the **Ethernet Network light** on the front of the Gateway **glows solid green**. Click **Next**.

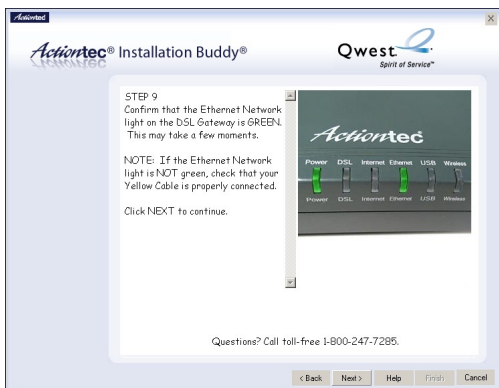

16. Get the **green cable** from the kit and plug one end into the **green Line port** on the rear panel of the Gateway. Click **Next**.



17. Plug the other end of the **green cable** into the **phone jack** closest to the computer. Click **Next**.



The Gateway is connected to a computer via Ethernet. Next, install the filters as described in “Installing Filters” on page 24.

Connecting Via USB

1. Insert the Installation CD in the CD-ROM drive of the computer. The Installation Buddy will start automatically. Wait until the following screen appears, read the on-screen instructions, then click **Next**.



Chapter 2 Setting Up the Gateway

2. Read the instructions, select **Initial Setup** by clicking on the appropriate check box, then click **Next**.



3. Select the appropriate modem payment option, then click **Next**.



4. Read the on-screen instructions regarding the terms and agreements of the rental contract, click in the white circle next to **I accept this agreement**, then click **Next**.

 **Note:** If “I purchased my modem from Qwest” was selected in step 3, go directly to step 5.

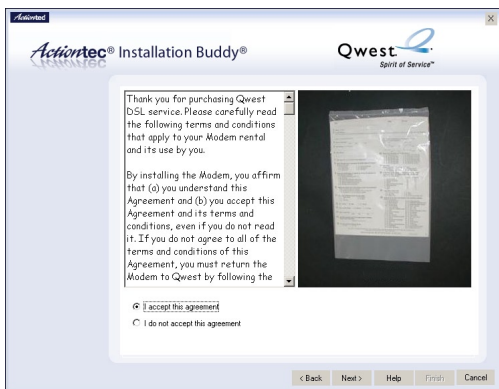

5. Click the check box next to **USB**, then click **Next**.



Chapter 2 Setting Up the Gateway

6. Get the Welcome Letter (or ISP Worksheet) provided by the ISP. Click **Next**.



7. Read the on-screen information concerning home security alarms, then click **Next**.

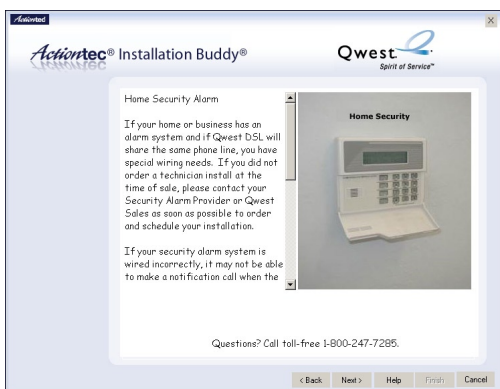

8. Make sure the items needed to connect the Gateway to the first computer on included in the kit, then click **Next**.

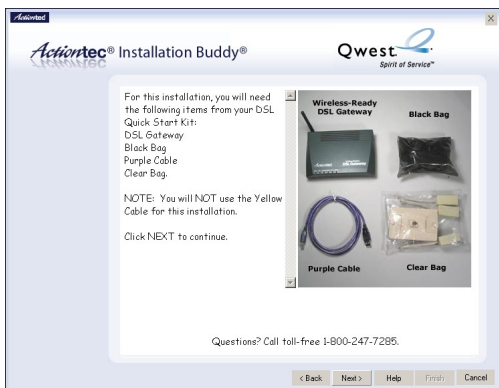

9. Get the Gateway from the kit, then click **Next**.



10. Get the **Power cord** from the black bag and plug the smaller end into the **black Power port** on the rear panel of the Gateway, then click **Next**.

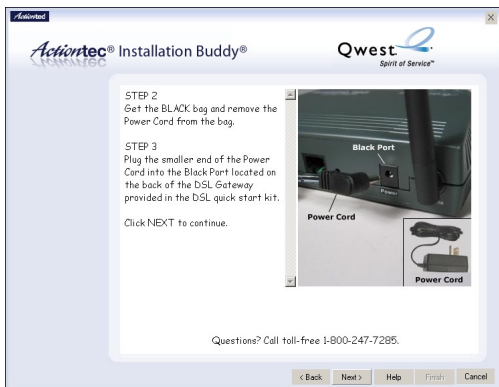

11. Plug the larger end of the **Power cord** into a **power outlet**, then click **Next**.

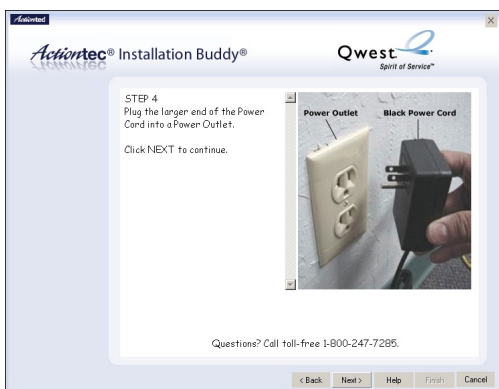

12. Confirm the **Power light** on the front of the Gateway **glows solid green**, then click **Next**.

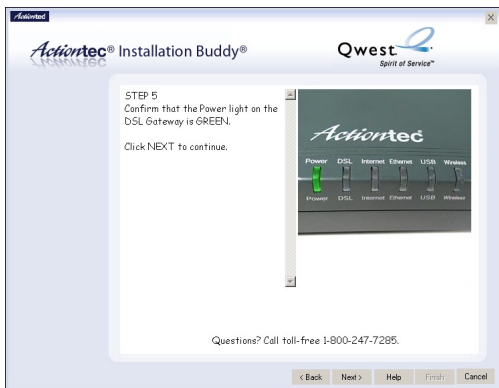

13. Get the **purple USB cable** from the kit and plug one end into the **Purple port** on the back of the Gateway, then click **Next**.



14. Plug the other end of the **purple USB cable** into a **USB port** on the front or back of the computer. Click **Next**.



15. Make sure the **USB light** on the front of the Gateway **glows solid green**. Click **Next**.

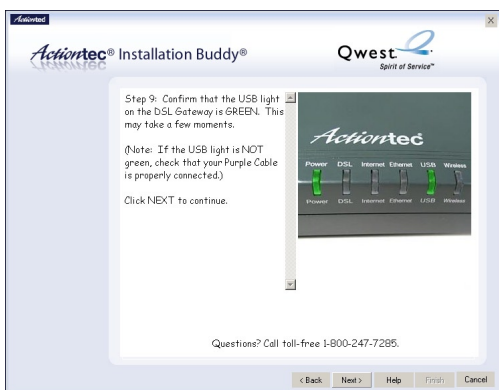

16. Get the **green DSL cable** from the kit and plug one end into the **green Line port** on the rear panel of the Gateway. Click **Next**.

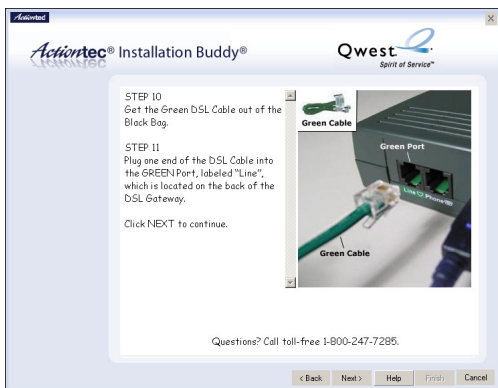

17. Plug the other end of the **green DSL cable** into the **phone jack** closest to the computer. Click **Next**.



The Gateway is connected to a computer via USB. Next, install the filters as described in "Installing Filters" on page 24.

Installing Phone Filters

Phone filters allow the use of the telephone while online. All telephones and other devices (answering machines, fax machines, etc.) using the same phone line (i.e., using the same phone number) as the DSL line must have a phone filter installed. To install a filter, follow these instructions:

1. Read the on-screen information, get the **Clear Bag**, then click **Next**.



2. Remove the phone filters from the **Clear Bag**. Click **Next**.

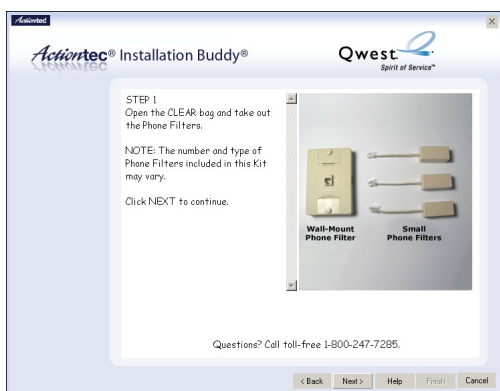

3. Read the on-screen information, then unplug all telephones and other devices from their phone jacks. Click **Next**.



 **Caution:** Do not unplug the green DSL cable from the phone jack near your computer.

4. Plug a phone filter into every phone jack with a telephone or other device connected to it, then plug the ends of the phone lines disconnected in step 3 into the phone filters plugged into wall jacks. Click **Next**.



 **Caution:** Do not plug a phone filter in the phone jack in which the green DSL cable is plugged.

5. If using a wall-mount phone, read the on-screen instructions, then click **Next**. If not installing a wall-mount phone filter, go step 7.



6. Install a wall-mount phone filter by removing the wall-mount telephone and opening the top and bottom toggles. Then, push the wall-mount filter onto the wall jack, push the toggles back into the closed position, and remount the wall-mount telephone. Click **Next**.



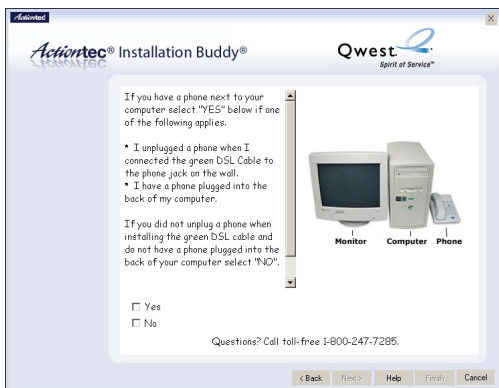

7. Answer the question (“Do you have a phone next to your computer?”) by clicking on the appropriate check box, then click **Next**.

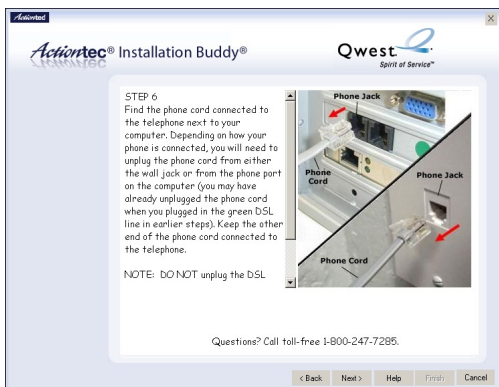

8. If you answered “No” in the previous window, go to “Setting up the DSL Connection” on page 31. If you answered “Yes,” unplug the phone cord connected to the telephone from its phone jack in the wall, then click **Next**.

 **Note:** You may have already unplugged this phone cord.



 **Caution:** Do not unplug the green DSL cable from the phone jack near your computer.

Chapter 2 Setting Up the Gateway

9. Plug the phone cord into the **Phone Jack** on the back of the Gateway. The connections should look like the configuration in the picture, below (if the first computer is connected via Ethernet; if the first computer is connected via USB, the purple cable will be plugged into the purple port). Click **Next**.

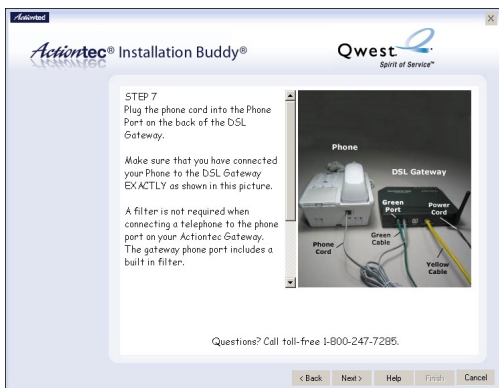

10. Read the on-screen information concerning automatic water meters, then click **Next**.



11. Make sure a phone filter is **NOT** connected to the green DSL cable, and that the green DSL cable is connected as shown on-screen.

Ethernet:



USB:



12. Make sure the appropriate **lights** on the front of the Gateway **glows solid green**. Click **Next**.
Ethernet:

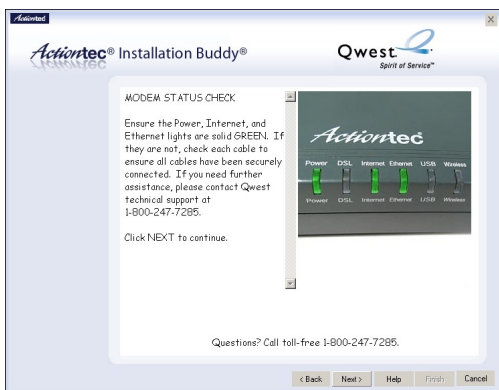

USB:

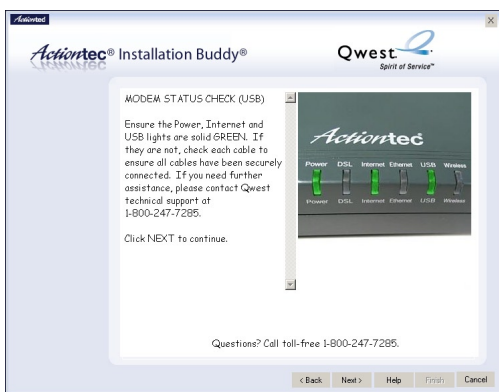

Next, go to “Setting Up the DSL Connection,” on the next page.

Setting Up the DSL Connection

After connecting the Gateway and installing phone filters, the DSL connection must be configured. To do this:

1. Read the on-screen instructions, choose the appropriate ISP option (indicated in the Welcome Letter), then click **Next**.
If **MSN** is selected, go to step 2.
If **Other IP** is selected, go to step 4.



2. Read the on-screen rental agreement, and if you accept it, click the circle next to "I accept the agreement." Click **Next**.

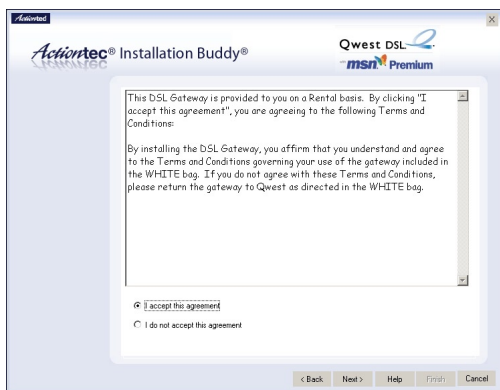

3. Enter the user name and password in the appropriate text boxes (or click the check box next to “My ISP does not require this information.”), then click **Next**. Then, go to step 8.
MSN users must enter their PPP User Name and PPP Password.



4. If **Other ISP** was selected in step 1, select the appropriate ISP protocol (**PPPoE**, **PPPoA**, or **RFC 1483**), as indicated in the Welcome Letter. If **PPPoE** or **PPPoA** is selected, got to step 5. If **RFC 1483** is selected, go to step 6.



5. Enter the user name and password in the appropriate text boxes (or click the check box next to “My ISP does not require this information.”), then click **Next**. Then, go to step 9.

Actiontec® Installation Buddy®

Qwest
Spirit of Service®

You now need to enter your PPP User Name and PPP Password below. The PPP User Name and PPP Password can be found on the ISP Welcome Letter (ISP Worksheet) provided by your ISP of choice. If you selected ISP is MSN or Qwest.net, the Welcome Letter will be included in your DSL Quick Start Kit. Other ISPs will provide their ISP Welcome Letter separately. Make sure you enter the PPP User Name and PPP Password EXACTLY as

PPP User Name
PPP Password

My ISP does not require this information.

Questions? Call toll-free

< Back Next > Help Finish Cancel

6. If RFC 1483 was selected in step 4, select the appropriate IP type. This information is available in the Welcome Letter. When finished, click **Next**.
If **Static IP** is selected, go to step 7.
If **Dynamic IP (DHCP)** is selected, got to step 9.

Actiontec® Installation Buddy®

Qwest
Spirit of Service®

Please select from the following IP types. The IP type will be provided by your ISP of choice and can be found on your ISP Welcome Letter (ISP Worksheet). Click NEXT to continue.

IP Type:
 Static IP
 Dynamic IP (DHCP)

Questions? Call toll-free 1-800-247-7285.

< Back Next > Help Finish Cancel

7. Select the type of Static IP address received from the ISP (**Single** or **Block**), then click **Next**.



8. Enter the **IP Address**, **Subnet**, **Gateway**, **DNS 1**, and **DNS 2** information (if applicable) in the proper text boxes. This information is available in the Welcome Letter. When finished, click **Next**.

Block of IP Addresses:

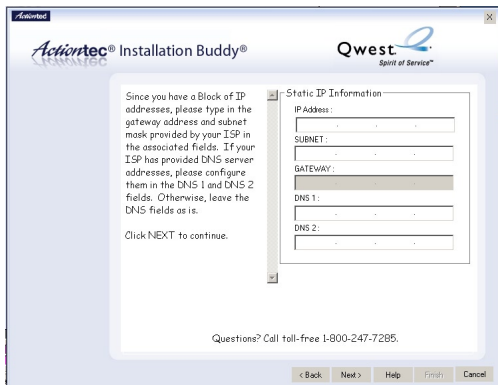

Single IP Addresses:

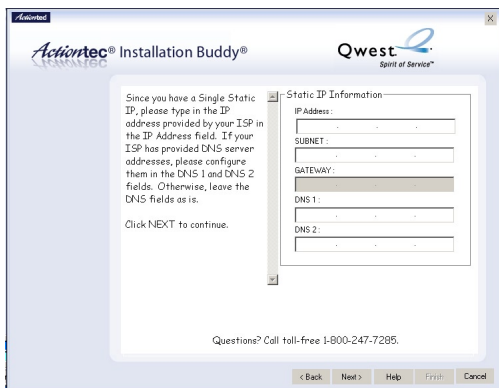

9. The Installation Buddy checks the configuration of the Gateway.

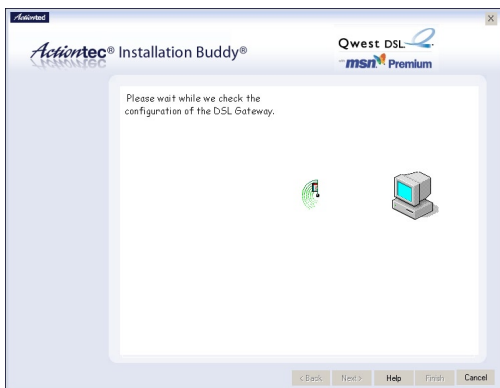

10. A “Congratulations” screen appears. Read the on-screen information, then click through the next few windows to exit the Installation Buddy.
MSN:



Other ISPs:



The Gateway is successfully configured and ready for use.

This page left intentionally blank.

Using Qwest DSL

3

Qwest DSL operates over home or business phone lines equipped with Qwest DSL service. For this reason, the Qwest DSL connection is not portable; it can't be accessed while away from the home or business. To connect while traveling, ask the ISP about a dial-up account. Most Qwest DSL ISPs provide a dial-up account for free, while others charge a minimal fee.

Qwest DSL is a highly reliable service, but it is possible to have a dial-up connection in the unlikely event that problems arise with the DSL service. Most Qwest DSL ISPs provide a dial-up account for free. If not, there are a number of free Internet providers whose products make great backup Internet access in the unlikely event they are ever needed.

Connecting to the Internet

Whether connecting via Point-to-Point Protocol (PPPoE, PPPoA) or Bridging Mode (RFC 1483), after connecting and configuring the Gateway, the Internet connection is always on. Therefore, to connect or reconnect to the Internet, simply turn on your computer, open the Web browser and go to the Web site of your choice. No further set up is needed.

Disconnecting from the Internet

Closing the Web browser does not disconnect you from the Internet. To fully disconnect, turn off your computer.

This page left intentionally blank.

Basic Setup

4

This chapter is a guide through a basic configuration of the Gateway, including how to connect the Gateway to the ISP.

To complete the basic setup, the user will need the Welcome Letter (ISP Worksheet). If the document is not available, contact the ISP immediately.

Basic Setup

To configure the gateway for basic operation:

1. Open the Web browser. In the address bar, enter
http://192.168.0.1
then press **Enter** on the keyboard.



2. The “Main Menu” screen appears. Select **Setup/Configuration**.

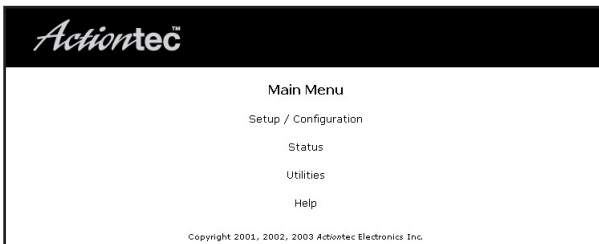

3. Follow the instructions in the “Set Up/Configuration” screen, then click **Begin Basic Setup**.

Basic Setup Change Admin Password Advanced Setup Non-Windows Setup	Set Up / Configuration <p>This section will guide you through the configuration of your DSL Modem.</p> <p>In most cases, only Basic Setup is required. In the event that you can not access the Internet after completing the Basic Setup, it is possible that your Internet Service Provider may require additional configuration.</p> <p>In this case, use the Advanced Setup process to configure your DSL Modem by clicking on the Advanced Setup option from the menu to the left.</p> <p>Please click the "Begin Basic Setup" button below to start the basic setup.</p> <p><input type="button" value="Begin Basic Setup"/></p>
--	--

4. In the next window, follow the on-screen instructions, then click **Next**.

Setup <p>Before you begin, please make sure you have completed the following steps below. Click Next to continue.</p> <ol style="list-style-type: none">1. Your DSL Modem is connected to your DSL line2. Your computers are connected to your DSL Modem <p><input type="button" value="Back"/> <input type="button" value="Next"/></p>

5. In the next window, select the type of connection by clicking on the circle next to **PPPoA** or **PPPoE**. If unsure about the selection, contact the ISP.

Broadband Connection <p>Please select the connection method that you use to access the Internet. Click Next to continue.</p> <p><input checked="" type="radio"/> PPPoE <input type="radio"/> PPPoA</p> <p><input type="button" value="Back"/> <input type="button" value="Next"/></p>
--

6. Enter the **User Name** and **Password** provided by the ISP in the “DSL Broadband Connection - PPP” screen. If the ISP provided a Static IP address, enter it in the **Static IP** text box. If not, leave it blank. Click **Next**.

DSL Broadband Connection - PPP

Please enter the **User Name** and **Password** required by your DSL Internet Service Provider to access the Internet.

You may obtain this information from your DSL Internet Service Provider. Click **Next** to continue.

User Name

Password

 *Note:* If you obtained a block of Static IP addresses, see Chapter 5, “Advanced Setup,” on page 35 to configure the Gateway.

7. Click **Save and Restart** in the “Save and Restart” screen.

Save and Restart

Please click the **Save and Restart** button below to save your settings and restart your Modem.

8. The “Congratulations” screen appears. The Gateway is successfully configured.

Congratulations!

Your DSL Gateway is now being configured.

Note: Your Home DSL Gateway will be ready to use when the Power LED stops flashing.

The Power Light flashes rapidly while the Gateway restarts, then glows steadily green when fully operational. The Internet Light will also glow steadily green. The Gateway is now configured and users can start surfing the Web. If an error stating the Web browser was unable to connect to the Internet appears, check the configuration settings. Ensure all the information required by the ISP is entered correctly.

This page left intentionally blank.

Setting Up Static IP Address

5

This chapter details how to set up the Gateway with a static IP address. The first section explains the configuration using a single static IP address; the second section explains the configuration using a block of static IP addresses.

Configuring for a Single Static IP Address

To set up the Gateway to use a single static IP address:

 **Note:** To complete this procedure, you must have access to the Internet Service Provider (ISP) worksheet. If no worksheet has been provided, contact the ISP.

1. Open the Web browser. In the address bar enter:
`http://192.168.0.1`
then press **Enter** on the keyboard.



2. The "Main Menu" screen appears. Select **Setup/Configuration**.

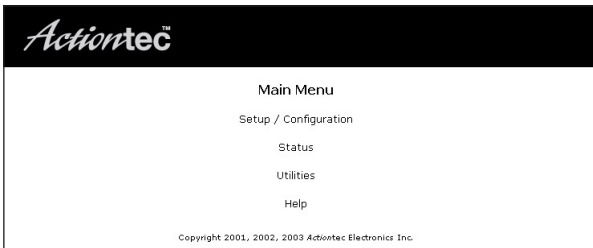

 **Note:** If the Main Menu screen does not appear, make sure the Ethernet cable is properly connected.

3. In the “Set Up/Configuration” screen, select **Non-Windows Setup** from the menu on the left side.

Basic Setup Change Admin Password Advanced Setup Non-Windows Setup	Set Up / Configuration This section will guide you through the configuration of your DSL Modem. In most cases, only Basic Setup is required. In the event that you can not access the Internet after completing the Basic Setup, it is possible that your Internet Service Provider may require additional configuration. In this case, use the Advanced Setup process to configure your DSL Modem by clicking on the Advanced Setup option from the menu to the left. Please click the "Begin Basic Setup" button below to start the basic setup. <input type="button" value="Begin Basic Setup"/>
--	---

4. The “Actiontec DSL Gateway Setup Page” screen appears. Using the Internet Service Provider (ISP) worksheet, enter the following information: ISP Protocol (select **RFC1483 Bridged**, **RFC1483 Routed**, **PPPoA**, or **PPPoE** by clicking in the appropriate circle), ISP Username, ISP Password (in the appropriate text boxes).

Actiontec DSL Gateway Setup Page The following will setup the router to work with your DSL provider.	
The Actiontec DSL Gateway setup page can be used to setup your Gateway for the following configurations. 1) RFC1483 Bridged with DHCP. Bridging session terminated in the GT701-WG; via a DHCP address from the ISP. DHCP/NAT is used on the LAN side to run multiple LAN devices. (Same for RFC1483 Routed) 2) RFC1483 Bridged with Static IP. Bridging session terminated in the GT701-WG; via a single Static IP address from the ISP. DHCP/NAT is used on the LAN side to run multiple LAN devices. (Same for RFC1483 Routed) 3) PPPoA with dynamic IP Addressing. (Same for PPPoE) 4) PPPoA with a Single Static IP Address. (Same for PPPoE)	
The advanced configuration session must be used to set the Gateway for transparent bridging and PPPoA with a block of static IP addresses.	
Please locate your Internet Service Provider(ISP) worksheet. The ISP worksheet is required to complete the following. The ISP worksheet is sent separately from your DSL fulfillment package directly from your ISP of choice. If you do not have an ISP worksheet, please contact your ISP directly.	
ISP Protocol	
Please select the protocol below listed on your ISP worksheet.	
<input type="radio"/> RFC1483 Bridged	
<input type="radio"/> RFC1483 Routed	
<input checked="" type="radio"/> PPPoA	ISP Username <input type="text"/>
	ISP Password <input type="text"/>
<input type="radio"/> PPPoE	ISP Username <input type="text" value="Not Applicable"/>

5. Scroll down to the IP Configuration section on the existing page, click on the circle next to “Static,” and enter the IP address obtained from the ISP worksheet in the IP text box.

IP Configuration

Please select your ISP addressing scheme listed on your ISP worksheet.

Dynamic

Static

IP

Subnet

Gateway

 **Note:** The “Subnet” and “Gateway” text boxes are not used during this procedure.

6. If provided with DNS settings on the ISP worksheet, click the circle next to “Static” and enter the DNS addresses in the “DNS Configuration” section at the bottom of the Actiontec DSL Modem Setup Page screen. If no DNS settings were provided, go to step 7.

DNS Configuration

Dynamic

Static

Primary DNS

Secondary DNS

NOTE: This page will setup the router for use with your DSL provider. In addition to setting up the router you may be required to perform additional configuration changes on your computer.

Thank you for choosing DSL as your high-speed access of choice.

Please click the **Save and Restart** button below to save your settings and restart your Gateway.

7. Click “Save and Restart” at the bottom of the screen.

- The “Save and Restart” page appears. Click “Save and Restart” to save the settings changed in the Actiontec DSL Modem Setup Page screen.

Save and Restart

Please click the **Save and Restart** button below to save your settings and restart your Gateway.

- Once the Gateway restarts, return to the Setup/Configuration screen and select **Change Admin Password** from the menu on the left side.

Basic Setup	Set Up / Configuration
Change Admin Password	This section will guide you through the configuration of your DSL Modem.
Advanced Setup	In most cases, only Basic Setup is required. In the event that you can not access the Internet after completing the Basic Setup, it is possible that your Internet Service Provider may require additional configuration.
Non-Windows Setup	In this case, use the Advanced Setup process to configure your DSL Modem by clicking on the Advanced Setup option from the menu to the left.
	Please click the "Begin Basic Setup" button below to start the basic setup.
	<input type="button" value="Begin Basic Setup"/>

- The “Change Admin Password” screen appears. Enter a new password in the “New Password” text box, and re-enter the password in the “Re-enter New Password” text box. Make sure to write this password down and keep it in a secure location. This password will be needed to access to the Gateway’s Web setup screens.

Change Admin Password

New Password

Re-enter New Password

Please click the **Save and Restart** button below to save your settings and restart your DSL Modem.

- Click “Save and Restart” at the bottom of the screen.

12. The “Save and Restart” page appears. Click “Save and Restart” to save the settings changed in the Change Admin Password screen.



The Gateway has been configured to support a single static IP address. Once the Power light stops blinking, the Gateway is ready for use.

Configuring for a Block of Static IP Addresses

To set up the Gateway to use a block of static IP addresses:

 **Note:** To complete this procedure, you must have access to the Internet Service Provider (ISP) worksheet. If no worksheet has been provided, contact the ISP.

1. Open the Web browser. In the address bar enter:
http://192.168.0.1
then press **Enter** on the keyboard.



2. The “Main Menu” screen appears. Select **Setup/Configuration**.



3. In the “Set Up/Configuration” screen, read the instructions, then select **Advanced Setup** from the menu on the left side.

Basic Setup Change Admin Password Advanced Setup Non-Windows Setup	Set Up / Configuration <p>This section will guide you through the configuration of your DSL Modem.</p> <p>In most cases, only Basic Setup is required. In the event that you can not access the Internet after completing the Basic Setup, it is possible that your Internet Service Provider may require additional configuration.</p> <p>In this case, use the Advanced Setup process to configure your DSL Modem by clicking on the Advanced Setup option from the menu to the left.</p> <p>Please click the "Begin Basic Setup" button below to start the basic setup.</p> <p style="text-align: center;"><input type="button" value="Begin Basic Setup"/></p>
--	--

4. Click **Begin Advanced Setup**.

Setup / Configuration <p>We strongly recommend that you keep the current default settings in this section for your Modem.</p> <p>However, if you would like to review and/or adjust these settings, please click the "Begin Advanced Setup" button below to start the advanced setup.</p> <p style="text-align: center;"><input type="button" value="Begin Advanced Setup"/></p>

5. The “Configuring the Advanced Settings” screen appears. Select **WAN IP Address** from the menu on the left side.

Advanced Setup WAN IP Address Wireless Settings Wireless MAC Authentication LAN IP Address DHCP Server Services Blocking Website Blocking Remote Management Port Forwarding DMZ Hosting Firewall Dynamic Routing NAT Static Routing Save and Restart	Configuring the Advanced Settings <p>The following settings will be configured in the order below. To skip ahead, please click on the selected setting from the menu to the left. Click Next to continue.</p> <ul style="list-style-type: none">• WAN IP Address• Wireless Settings• Wireless Authentication• LAN IP Address• DHCP Server• Services Blocking• Website Blocking• Remote Management• Port Forwarding• DMZ Hosting• Firewall• Dynamic Routing• NAT• Static Routing <p style="text-align: center;"><input type="button" value="Back"/> <input type="button" value="Next"/></p>
---	--

Copyright 2001, 2002, 2003 Actiontec Electronics Inc.

6. Select “Obtain an IP Address through PPPoA,” select “Unnumbered Mode,” then enter the gateway and subnet mask addresses assigned by the ISP in the “Gateway Address” and “Unnumbered Subnet Mask” text boxes, respectively. These addresses should be included on the ISP worksheet. Click **Next**.

WAN IP Address

Please make the appropriate selection for your Broadband connection.

Transparent Bridging (RFC1483 Bridged)
 Obtain an IP Address through PPPoE
 Obtain an IP Address through PPPoA
 Obtain an IP Address through DHCP
 Specify a Static IP Address

Encapsulation: RFC1483 Bridged RFC1483 Routed

Unnumbered Mode
 VIP Mode

Unnumbered IP Address:

(Gateway Address)
 (Unnumbered Subnet Mask)

7. In the “Broadband Connection via PPPoA” screen, enter the user name and password assigned by the ISP in the appropriate text boxes, then click **Next** four times.

Broadband Connection via PPPoA

Please enter the username, password required by your DSL Internet Service Provider to access the Internet.

PPP auto connect

Encapsulation: VC-MUX LLC/SNAP

User Name
Password
Static IP

- In the “DHCP Server Configuration” screen, select “Static” from the “DNS” options near the center of the screen, then enter the DNS Server IP addresses assigned by the ISP in the appropriate text boxes.

DHCP Server Configuration

Beginning IP Address:

Ending IP Address:

SubnetMask:

DNS: Dynamic Static

DNS Server 1:

DNS Server 2:

 **Note:** If the ISP did not provide static DNS addresses, leave the DNS option at “Dynamic.” Also, if the DHCP server option is turned off, this screen will not appear. The Gateway will obtain dynamically assigned DNS addresses if supported by the ISP with static IP addresses.

- Click “Save and Restart” from the menu on the left side.
- The “Save and Restart” page appears. Click “Save and Restart” to save the settings.

Save and Restart

Please click the **Save and Restart** button below to save your settings and restart your Gateway.

- Once the Gateway restarts, return to the Setup/Configuration screen and select **Change Admin Password** from the menu on the left side.

Basic Setup Change Admin Password Advanced Setup Non-Windows Setup	Set Up / Configuration This section will guide you through the configuration of your DSL Modem. In most cases, only Basic Setup is required. In the event that you can not access the Internet after completing the Basic Setup, it is possible that your Internet Service Provider may require additional configuration. In this case, use the Advanced Setup process to configure your DSL Modem by clicking on the Advanced Setup option from the menu to the left. Please click the Begin Basic Setup button below to start the basic setup. <input type="button" value="Begin Basic Setup"/>
--	---

- The “Change Admin Password” screen appears. Enter a new password in the “New Password” text box, and re-enter the password in the “Re-enter New Password” text box. Make sure to write this password down and keep it in a secure location. This password will be needed to access to the Gateway’s Web setup screens.

Change Admin Password

New Password

Re-enter New Password

Please click the **Save and Restart** button below to save your settings and restart your DSL Modem.

- Click “Save and Restart” at the bottom of the screen.
- The “Save and Restart” page appears. Click “Save and Restart” to save the settings changed in the Change Admin Password screen.

Save and Restart

Please click the **Save and Restart** button below to save your settings and restart your Gateway.

The Gateway has been configured to support a block of static IP addresses. Once the Power light stops blinking, the Gateway is ready for use.

This page left intentionally blank.

Advanced Setup

6

This section contains information concerning advanced configuration, such as wireless settings, remote management, and Web site blocking.

Accessing Advanced Setup

To access the Advanced Setup configuration screens, follow these instructions:

1. Open the Web browser. In the address bar enter:
http://192.168.0.1
then press **Enter** on the keyboard.



2. The "Main Menu" screen appears. Select **Setup/Configuration**.

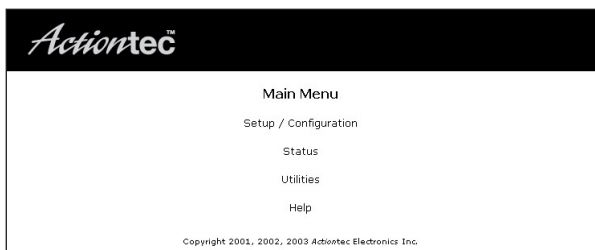

3. In the "Set Up/Configuration" screen, read the instructions, then select **Advanced Setup** from the menu on the left side.

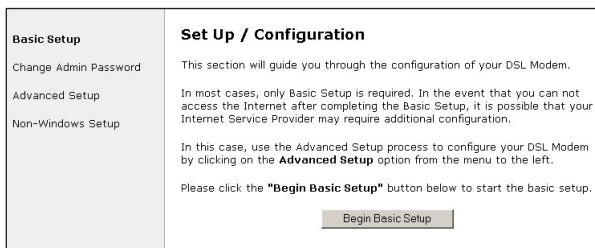

- In the next screen, read the recommendations. To perform an advanced setup on the Gateway, click **Begin Advanced Setup**.

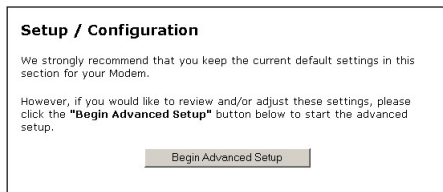

- The “Configuring the Advanced Settings” screen appears. To check all the settings, or if unsure of which settings to modify, select **Next**. To modify a specific configuration, click on its name in the menu bar on the left.



 **Note:** To save changes made in any of the Advanced Setup screens, click Save and Restart at the bottom of the gray menu on the left side of the screen.

WAN IP Address

Selecting **WAN IP Address** in the “Advanced Configuration” screen generates the “WAN IP Address” screen. WAN IP Address allows manual set up of the IP address of the Gateway. There are five ways to do this: **Transparent Bridging**, **Obtain an IP Address through PPPoE**, **Obtain an IP Address Through PPPoA**, **Obtain an IP Address through DHCP**, and **Specify a Static IP Address**.



Note: Some DSL providers use PPPoE/PPPoA to establish communication with an end user. Other types of broadband Internet connections (such as fixed point wireless) may use either DHCP or Static IP address. If unsure about which connection is present, check with the Internet Service Provider (ISP) before continuing.

After selecting a connection type, click **Next** to continue configuring the connection.

WAN IP Address

Please make the appropriate selection for your Broadband connection.

Transparent Bridging (RFC1483 Bridged)
 Obtain an IP Address through PPPoE
 Obtain an IP Address through PPPoA
 Obtain an IP Address through DHCP
 Specify a Static IP Address

Encapsulation: RFC1483 Bridged RFC1483 Routed

Unnumbered Mode
 VIP Mode

Unnumbered IP Address:

(Gateway Address)
 (Unnumbered Subnet Mask)

Transparent Bridging

Select this option to use the Gateway as a transparent bridge. This option should only be used if the Gateway is being used as a Modem to connect one computer to the Internet via a DSL connection. When the Gateway is being used as a transparent bridge, it does not provide any firewall security.

Obtain an IP Address through PPPoE or PPPoA

Select one of these options to allow the Gateway to use the Point-to-Point over Ethernet (PPPoE) or Point-to-Point over ATM (PPPoA) protocol.

Broadband Connection via PPPoE/PPPoA

Please enter the username, password and static IP required by your DSL Internet Service Provider to access the Internet.

PPP auto connect

User Name

Password

Static IP

If a **User Name**, **Password** and/or **Static IP** was entered during Basic Setup, it should be displayed in the “Broadband Connection via PPPoE/PPPoA” screen. If not, enter the information now. If the information is unavailable, contact the Internet Service Provider (ISP).

PPP Auto Connect

If **PPP auto connect** is activated (by clicking in the appropriate check box), the Gateway will attempt to automatically redial the PPP connection if it is dropped or disconnected during an online session.

Obtain an IP Through DHCP

Select this option if the IP service is configured to use RFC 1483 Bridged or Routed (used for configurations without a Static IP assigned by an ISP). In this mode, the Gateway will query the Internet Service Provider (ISP) to receive the IP address and routing information, which will terminate at the Gateway, as opposed to the IP address and routing information being bridged to terminate at the computer. This allows the use of the router capabilities for the Local Area Network (LAN).

Some ISPs need to authenticate their end users with a **Host Name** and/or **Domain Name**. If this is the case, check with the ISP for a host name and domain name and enter them in the “Broadband Connection via DHCP” screen. If the ISP does not require these settings, leave the text boxes blank.

 **Note:** Contact the ISP if unsure of the proper configuration.

Broadband Connection via DHCP

If your Broadband Service Provider requires a Host Name or Domain Name to access the Internet, please enter it below. Otherwise, click **Next** to continue.

Host Name

Domain Name

Specify a Static IP Address

Select this option if the ISP service is configured to use RFC 1483 Bridged or Routed using a Static IP Address. Enter the **IP Address**, **Subnet Mask**, and **Default Gateway Address** provided by the ISP in the “Broadband Connection via Static IP Address” screen, which causes the IP address and routing information to terminate at the Gateway, as opposed to the IP address and routing information being bridged to terminate at the computer. This allows the use of the router capabilities for the Local Area Network (LAN).

Broadband Connection via Static IP Address

Please enter your **Static IP Address** and **Default Gateway Address** provided to you by your Internet Service Provider.

Click **Next** to continue.

IP Address:

Subnet Mask:

Default Gateway Address:

 **Note:** Contact the ISP if unsure of the proper configuration.

Encapsulation

If the Gateway is configured to obtain an IP address through DHCP or to specify a static IP address, select the appropriate encapsulation option used by the ISP (**RFC 1483 Bridged** or **RFC 1483 Routed**).

WAN IP Address

Please make the appropriate selection for your Broadband connection.

Transparent Bridging (RFC1483 Bridged)

Obtain an IP Address through PPPoE

Obtain an IP Address through PPPoA

Obtain an IP Address through DHCP

Specify a Static IP Address

Encapsulation: RFC1483 Bridged RFC1483 Routed

Unnumbered Mode

VIP Mode

Unnumbered IP Address:

(Gateway Address)

(Unnumbered Subnet Mask)

 **Note:** Contact the ISP if unsure of the proper configuration.

Unnumbered Mode/VIP Mode

If a block of public static IP addresses was purchased from the ISP, select **Unnumbered Mode** by clicking in the appropriate check box. Then, enter the **IP Address** and **Subnet Mask** in the “Gateway Address” and “Unnumbered Subnet Mask” text boxes below the “Unnumbered IP Address.” Click **Next**, then click **Save and Restart** to make all changes permanent.

The Unnumbered Mode feature automatically configures the appropriate IP routing for the IP Address block. The IP route will bypass NAT, enabling the public IPs to be routed WAN-to-LAN, as well as LAN-to-WAN.

 **Note:** The IP Address information should be obtained from the ISP when purchasing a block of public static IP address. Contact the ISP if this information was not received.

VIP Mode - This feature is used in conjunction with Unnumbered Mode. When VIP Mode is activated, the Gateway uses NAT for private IP Addressing for the Local Area Network (LAN), allowing both Public IP Addressing and Private IP Addressing to be configured to the LAN simultaneously, while the DHCP server is reserved for Private IP Addressing. All computers using Public IP Addresses with Unnumbered Mode must have the Public IP Addresses statically assigned.

After configuring your settings, click **Next**, then click **Save and Restart** to make all changes permanent.

Wireless Settings

Selecting **Wireless Settings** in the “Advanced Configuration” screen generates the “Wireless Settings” screen. To activate the wireless “radio” of the Gateway, click in the circle next to “On.” To turn it off, click in the circle next to “Off.”

Wireless Settings

If you are using Wireless Networking, we recommend that you change the default settings and turn on the WEP encryption. The values you define on this screen must also be used for all your wireless computers.

Note: The current default wireless settings for your Gateway are: ESSID is **ACTIONTEC**, channel is **1**, and WEP encryption selection value is **Off**.

Click **Next** to continue.

Wireless: On Off

ESSID:

Channel:

Security: Off WEP WEP+802.1x WPA

NOTE: WEP (Wired Equivalent Privacy), WEP+802.1x, and WPA are optional security measures for your wireless network.

ESSID

ESSID is the network name assigned to the wireless network. The factory default setting is “ACTIONTEC.” Although *Actiontec* recommends keeping the default value intact, the ESSID value can be modified, using any combination of alphanumeric characters (i.e., A-Z, a-z, 0-9). All wireless-capable computers included on the Gateway’s wireless network must have this same ESSID value. (For the *Actiontec* 802.11b Wireless PC Card, the ESSID value must be the same as the SSID value.)

Channel

Channel assigns the frequency band at which the Gateway communicates. In the United States, use channels 1-11. (The factory default value is set to 1.)

Security

There are four wireless security options: Off, WEP, WEP+802.1x, and WPA. The latter three options are different types of wireless security.

Off

Selecting **Off** disables wireless security. Selecting this option allows any computer with wireless capability and the correct ESSID value to join the wireless network.

WEP

Selecting the security option “WEP” in the Wireless Settings screen generates the “WEP Key” screen. Here, the authentication type, encryption level, and WEP keys are entered to activate WEP (Wired Equivalent Privacy) security encryption for the wireless network.

The screenshot shows a web-based configuration interface titled "Wireless Settings: WEP Key". At the top, there is a label "Authentication Type:" followed by a dropdown menu currently set to "Open". Below this, there are four rows, each labeled "Key 1:" through "Key 4:". Each row contains a text input field for the key and a dropdown menu set to "64 bits". At the bottom of the form, there is a small note: "NOTE: A hexadecimal digit consists of alphanumeric characters in the range 0-9 or A-F. A 64-bit encryption value should appear like this: 4D 33 EF C6 1A". At the very bottom, there are two buttons: "Back" and "Next".

Authentication Type - There are three authentication types: Open, Shared, and Both. Open authentication allows any wireless-enabled device to recognize the Gateway, if the correct WEP key is enabled on the device. Shared allows only wireless-enabled devices with the correct WEP key and Shared key to recognize the Gateway. Selecting Both enables both Open and Shared authentication types.

64-bit WEP - 64-bit WEP requires four separate keys. Each key comprises five hexadecimal digit pairs. A hexadecimal digit consists of an alphanumeric character ranging from 0-9 or A-F. An example of a 64-bit WEP key is: 4E-A3-3D-68-72. To create a set of 64-bit WEP keys, activate all four keys by clicking in the appropriate circles, then enter five hexadecimal digit pairs in each **Key** text box (**Key 1**-, **Key 2**-, **Key 3**-, **Key 4**-). After activating 64-bit WEP on the Gateway, a computer with wireless capability can join the network only if these same keys are entered in the computer's wireless encryption scheme.

128-bit WEP - 128-bit WEP requires one key, comprising 13 hexadecimal pairs. A hexadecimal digit consists of alphanumeric characters ranging from 0-9 or A-F. An example of a 128-bit WEP key is: 3D-44-FE-6C-A1-EF-2E-D3-C4-21-74-5D-B1. To create a 128-bit WEP key, activate **Key 1** by clicking in the appropriate circle, then enter 13 hexadecimal digit pairs in the **Key** text box. After activating 128-bit WEP on the Gateway, a computer with wireless capability can join the network only if this key is entered in the computer's wireless encryption scheme.

256-bit WEP - 256-bit WEP requires one key, comprising 29 hexadecimal pairs. A hexadecimal digit consists of alphanumeric characters ranging from 0-9 or A-F. An example of a 256-bit WEP key is: 3D-44-FE-6C-A1-EF-2E-D3-C4-21-74-5D-B1. To create a 256-bit WEP key, activate **Key 1** by clicking in the appropriate circle, then enter 29 hexadecimal digit pairs in the **Key** text box. After activating 256-bit WEP on the Gateway, a computer with wireless capability can join the network only if this key is entered in the computer's wireless encryption scheme.



Note: Not all wireless PC Cards support 128- or 256-bit WEP. Ensure that all PC Cards installed in the networked computers support 128- or 256-bit WEP before activating.

WEP+802.1x

Activating **WEP+802.1x** and clicking **Next** in the Wireless Settings screen generates the “Wireless 802.1x Security Settings” screen. This setting is for enterprise networks only, and should be accessed by experienced information systems specialists only.

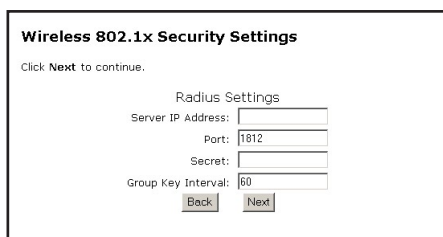

Wireless 802.1x Security Settings

Click **Next** to continue.

Radius Settings

Server IP Address:

Port:

Secret:

Group Key Interval:

To set up WEP+802.1x security, enter the IP address of the RADIUS server in the “Server IP Address” text box, and the “Secret” key (for communication between the RADIUS server and the Router) in the “Secret” text box. The “Port” and “Group Key Interval” values should remain the same

WPA

Activating **WPA** (Wi-Fi Protected Access) and clicking **Next** in the Wireless Settings screen generates the “Wireless WPA Settings” screen.

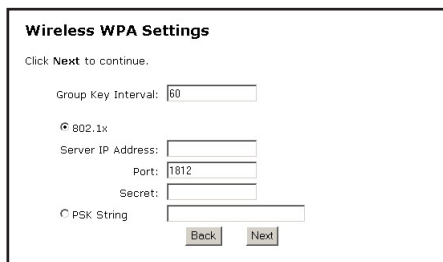

Wireless WPA Settings

Click **Next** to continue.

Group Key Interval:

802.1x

Server IP Address:

Port:

Secret:

PSK String

There are two levels of WPA. The “Group Key Interval,” “Server IP Address,” “Port,” and “Secret” text boxes, along with the “802.1x” radio button, are enterprise network specific, and should only be accessed by an experienced information systems professional. See “WEP+802.1x” on the previous page for more information.

“PSK String” is for home network security. To set up a PSK (**Pre-Shared Key**), click in the circle next to **PSK String**, then enter at least eight alphanumeric characters in the text box. All wireless-enabled devices must support WPA and know the PSK to join the network.

Important: Wireless networking devices use public radio channels to transmit voice and data communications. Although WEP is the standard security technology used today and offers some degree of security, Qwest cannot guarantee the security, privacy, or confidentiality of any transmissions made via such devices, and Qwest makes no assurances or warranties relating to their use by you. You are responsible for all use of your Qwest DSL service, regardless of the source of a transmission, whether by you or an authorized third party, over your Qwest DSL service.

Wireless MAC Authentication

Selecting **Wireless MAC Authentication** in the “Advanced Configuration” screen generates the “Wireless MAC Authentication” screen.

The screenshot shows a web-based configuration interface titled "Wireless MAC Authentication". At the top, it instructs the user to "Enter the MAC address of the wireless client which you wish to either block or allow access to your network." Below this, there are two radio button options: "Accept all clients" (which is selected) and "Deny all clients". There is also an unchecked checkbox for "Enable Access List". Underneath, there is an "Exception List" section with a note that entries should appear like "00-20-e0-00-41-00". It includes a text input field, an "Add" button, and a "Remove" button. At the bottom, there is a "Client MAC address:" label followed by another text input field. Finally, there are "Back" and "Next" buttons at the very bottom of the form.

This feature allows the user to control the Wireless LAN Network by denying or allowing wireless access by specifying the MAC Address of the wireless client(s) allowed or denied on the wireless network

After changing settings, click Next or Back to continue, or Save and Restart to make all changes permanent.

LAN IP Address

Selecting **LAN IP Address** in the “Advanced Configuration” screen generates the “LAN IP Address” screen.

LAN IP Address

We recommend that you keep the current default LAN IP Address of the Gateway as 192.168.0.1.

To make changes, enter in the new IP Address value below. Click **Next** to continue.

LAN IP Address:

(Device IP Address)

(Device LAN Netmask)

The values in the “LAN IP Address” and “Netmask” text boxes are the IP address and Subnetmask of the Gateway as seen on the network. These values can be modified for your LAN network, but Actiontec recommends keeping the default factory settings (IP Address 192.168.0.1 Subnetmask 255.255.255.0).

 **Note:** If the Gateway’s LAN IP Address is modified, verify the DHCP Server range is within the same subnet. For more information, see “DHCP Server Configuration.”

After changing settings, click Next or Back to continue, or Save and Restart to make all changes permanent.

DHCP Server

Selecting **DHCP Server** in the “Advanced Configuration” screen generates the “DHCP Server” screen. The Gateway has a built-in DHCP (Dynamic Host Configuration Protocol) server that automatically assigns a different IP address to each computer on the network, eliminating IP address conflicts. The factory default setting is **On**. To disable the DHCP Server, select **Off**.

DHCP Server

Your Modem will automatically assign an IP Address to each computer in your network.

We recommend that you keep the current default DHCP Server settings. If you already have a DHCP server in your network, you may need to turn this function off.

Click **Next** to continue.

On **Off**

Actiontec strongly recommends leaving the DHCP Server option **On**. If the DHCP Server option is **Off**, ensure the IP addresses of the networked computers are on the same subnet as the IP address of the Gateway. For more information, see “DHCP Server Configuration.”

DHCP Server Configuration

Clicking **Next** in the “DHCP Server” screen generates the “DHCP Server Configuration” screen. Change IP address range and DNS server information here.

DHCP Server Configuration

Beginning IP Address:

Ending IP Address:

SubnetMask:

DNS: **Dynamic** **Static**

DNS Server 1:

DNS Server 2:

Beginning IP Address - the IP address at which the DHCP server starts assigning IP addresses. *Actiontec* recommends keeping the factory default setting (192.168.0.2).

Ending IP Address - the IP Address at which the DHCP Server stops assigning IP addresses. *Actiontec* recommends keeping the factory default settings (192.168.0.254).

The beginning and ending IP addresses define the IP address range of the Gateway. If the default values are left intact, the Gateway supplies a unique IP address between 192.168.0.2 and 192.168.0.254 to each computer on the network. Note that the first three groups of numbers of the addresses are identical; this means they are on the same subnet. The IP address of the Gateway must be on the same subnet as the IP address range it generates. For instance, if the Gateway’s IP address is changed to 10.33.222.1, set the beginning IP address to 10.33.222.2, and the ending IP address to 10.33.222.254.

DNS (Dynamic or Static) - the type of DNS server provided by the Internet Service Provider (ISP). If the ISP provided DNS server information, select the type here. If not, leave as is.

DNS Server 1 - the primary DNS server provided by the Internet Service Provider (ISP). If the ISP provided DNS server information, enter it here. If not, leave the text box intact.

DNS Server 2 - the secondary DNS provided by the Internet Service Provider (ISP). If the ISP provided secondary DNS server information, enter it here. If not, leave the text box intact.

Services Blocking

Selecting **Services Blocking** in the “Advanced Configuration” screen generates the “Services Blocking” screen.

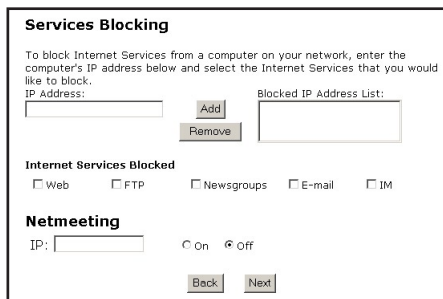

The screenshot shows the "Services Blocking" configuration screen. At the top, it says "Services Blocking". Below that, a paragraph explains: "To block Internet Services from a computer on your network, enter the computer's IP address below and select the Internet Services that you would like to block." There are two text boxes: "IP Address:" and "Blocked IP Address List:". Between them are "Add" and "Remove" buttons. Below the "IP Address:" box is a "Remove" button. Underneath, there is a section "Internet Services Blocked" with checkboxes for "Web", "FTP", "Newsgroups", "E-mail", and "IM". Below that is a "Netmeeting" section with an "IP:" text box and radio buttons for "On" and "Off". At the bottom are "Back" and "Next" buttons.

To modify Internet privileges (Web, FTP, Newsgroups, etc.) for the computers on the network:

1. Enter the computer's IP address in the **IP Address:** text box.
2. Select the Internet service(s) to be blocked.
3. Click **Add** to enter the computer's IP address in the “Blocked IP Address List” text box.
4. To remove blocked services, select the computer's IP address in the “Blocked IP Address List” text box and click **Remove**.

Netmeeting

If a computer on the network uses Netmeeting, enable Netmeeting, by clicking the circle next to “On” and entering the IP address of the computer. Click **Next**, then click **Save and Restart** to apply the settings. If Netmeeting is not needed, click the circle next to “Off.”

 **Note:** Netmeeting is used for NAT/Private IP addressing only. If the computer is configured for Unnumbered Mode and has a Public IP Address, Netmeeting does not have to be enabled.

Website Blocking

Selecting **Website Blocking** in the “Advanced Configuration” screen generates the “Website Blocking” screen. This feature enables the Gateway to block Web sites to all computers on the network. To block a Web site, enter the address of the Web site in the “Website” text box and click **Add**. The blocked Web site address will be displayed in the “Blocked Website List” text box, and will not be available to computers on the network. To remove a blocked Web site, click on it in the “Blocked Website List,” then click **Remove**.

Website Blocking

To block a specific website, please enter the name of the website such as **www.actiontec.com** in the space below. Then click the **Add** button to activate.

To remove a website from the Blocked Websites List, please select the website and click the **Remove** button. Click **Next** to continue.

Website:

Blocked Website List:

Remote Management

Selecting **Remote Management** in the “Advanced Configuration” screen generates the “Remote Management” screen. Remote Management allows access to the Gateway through the Internet via another computer. *Actiontec* recommends leaving the Remote Management **Off** (the factory default setting).

Remote Management

The default Remote Management setting is **Off** for security reasons. If you want to access your Modem remotely, please select **On**.

Remote Management: On Off

To access the Gateway from the Internet, activate Remote Management by selecting **On** and writing down the WAN IP address of the Gateway (see “WAN IP Address”). On a computer outside of the network, open a Web browser and enter the Gateway’s WAN IP address in the address text box. The Gateway’s Main Menu (or a password prompt, if a password has been set) appears in the browser window.

 **Note:** Before Remote Management can be activated, the administrator password must be set. To do this, go to the Setup screen and select Change Admin Password. Follow the instructions in the subsequent screens

Port Forwarding

Selecting **Port Forwarding** in the “Advanced Configuration” screen generates the “Port Forwarding” screen. Port forwarding allows certain programs to bypass the Gateway’s built-in firewall, allowing access to parts of the network (for hosting a Web or ftp server, for example). To use port forwarding, enter the IP port range in the “IP Port Range” text boxes. (If more than 10 ports are needed, *Actiontec* recommends using DMZ Hosting. See “DMZ Hosting,” below, for more information.)

Choose the protocol type from the “Protocol” list box, then enter the IP address of the computer on the network to be used as a host. Click **Add**. The forwarded ports appear in the “List of Forwarded Ports” text box.

To remove forwarded ports, highlight them, then click **Remove**.

Port Forwarding

Some internet applications require certain ports to be forwarded. Please enter the required port ranges and IP Address of the computer running the application into the space below, then click Add. Click Advanced for more options, or click Next to continue.

IP Port Range: [] to [] Protocol: TCP ▼ IP Address: []

[Add] [Remove]

List of Forwarded Ports

[] [Advanced...]

[Back] [Next]

Clicking **Advanced** brings up the “Advanced Port Forward” screen.

Advanced Port Forwarding

Please enter ports and port ranges, that some internet applications require to be forwarded, in the spaces below.

IP Port Range: [] to [] Protocol: TCP ▼ IP Address: []

Remote IP Port Range: [0] to [65535] Any IP / Remote IP Address: [anyIP]

[Add] [Remove]

List of Forwarded Ports

[] [Back] [Next]

In this screen, the user can allow only certain IP addresses to access forwarded ports. Enter the port range of the forwarded ports in the “Remote IP Port Range” text boxes, enter the IP address to be allowed access in the “Remote IP Address” text box, then click “Add.” The active forwarded ports will appear in the “List of Forwarded Ports” text box.

To deactivate a forwarded port, select it from the “List of Forwarded Ports” text box, then click “Remove.”

DMZ Hosting

Selecting **DMZ Hosting** in the “Advanced Configuration” screen generates the “DMZ Hosting” screen. To use DMZ hosting, enter the IP address of the computer on the network to be used as a DMZ host in the “DMZ Host IP Address” text box, then click **On**.

DMZ Hosting

Your Modem can be configured to support Online Gaming and Internet Conferencing services on a network computer. To use this feature, enter the IP Address of the computer in the DMZ Host field below.

Warning: Using a computer in DMZ mode opens the computer to outside intrusion, creating a security risk.

DMZ Host IP Address

On Off

DMZ hosting is used to support online gaming and Internet conferencing services. These programs usually require multiple open ports, making the network accessible from the Internet. DMZ hosting symbolically places the DMZ host computer outside of the Gateway’s network. Access to the network resources while DMZ hosting is active is blocked. Actiontec recommends activating DMZ hosting only as long as necessary.

 **Warning:** The DMZ Host computer will be vulnerable to computer hackers on the Internet while in DMZ mode.

Firewall

Selecting **Firewall** in the “Advanced Configuration” screen generates the “Firewall Security Level” screen. Select the level of security needed for the network. See Appendix E for details concerning each level of security.

Firewall Security Level

The default Firewall Security Level is set to "Basic". You can change the Firewall Security Level to suit your networking needs.

(Note: Once you have selected a security level, all IP traffic other than the policies specified will be blocked by the Firewall. Refer to the User Manual for detailed information on Firewall policies.)

High
 Medium
 Low
 Basic

Dynamic Routing

Selecting **Dynamic Routing** in the “Advanced Configuration” screen generates the “Dynamic Routing” screen.

Dynamic Routing

RIP Version 1 Settings: Select "Enable" to enable Dynamic Routing. The default setting is "Disable" which disables Dynamic Routing.

Enable
 Disable

If a gateway is set up behind the Gateway in the network configuration, consult the documentation that came with the gateway to see what kind of Dynamic Routing is required, then select the needed option.

NAT (Network Address Translation)

Selecting NAT in the “Configuring the Advanced Settings” screen generates the “NAT” screen. The Gateway’s basic firewall security is based on NAT. Disabling NAT allows the computers connected to the Gateway to be accessed by outside parties. Do not turn NAT off unless instructed to do so by the Internet Service Provider (ISP).

NAT

Warning: Please do not disable NAT unless instructed to do so by your ISP. Turning off NAT will open your modem to outside intrusion, creating a security risk.

NOTE: If you turn NAT off, you **MUST** specify a static route for your local subnet. However, if you have configured an Unnumbered IP address then you will not need to disable NAT and/or enter any Static Route.

Click **Next** to continue.

On Off

Static Routing

Selecting **Static Routing** in the “Advanced Settings” screen generates the “Static Routing” screen. Enter the addresses in their respective text boxes, then click **Add**. The address will appear in the “Static Routing Table.” To remove an address, highlight it by clicking on it in the Static Routing Table, then click **Remove**.

Static Routing

Static Routes can be entered in the spaces below. "Subnet IP" is the IP address of the subnet being defined. "Subnet Mask" is the subnet mask of the subnet being defined. "Gateway IP" is the IP address of the gateway and can be empty for the local subnet.

Subnet IP	Subnet Mask	Gateway IP
<input type="text"/>	<input type="text"/>	<input type="text"/>
<input type="button" value="Add"/>	<input type="button" value="Remove"/>	<input type="button" value="View"/>

Static Routing Table

--

Status

After configuring the Gateway, settings can be viewed by selecting **Status** in the Main Menu. The “Current Status” screen appears, displaying many of the Gateway’s settings. No settings (other than connecting or disconnecting from the Internet) can be changed from the Current Status screen.

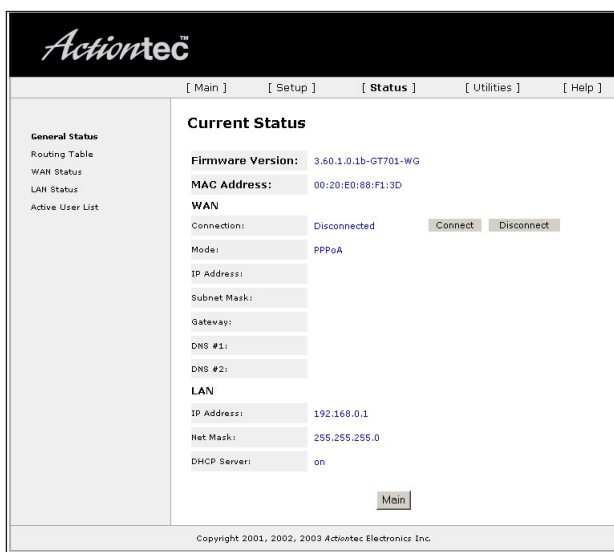

Firmware Version

Displays the firmware version the Gateway is currently running.

MAC Address

Displays the MAC (Media Access Control) address of the Gateway.

WAN - Connection

Displays the state of the connection to the ISP service (Connected or Disconnected).

WAN - Mode

Displays the type of connection used to communicate with the ISP.

WAN - IP Address

Displays the IP Address the ISP assigned to the Gateway.

WAN - Subnet Mask

Displays the Subnet Mask address the ISP assigned to the Gateway.

WAN - Gateway

Displays the Gateway address (for the IP Address and Subnet Mask) the ISP assigned to the Gateway.

WAN - DNS #1 & #2

Displays the Domain Name Server address(es) the ISP assigned to the Gateway.

LAN - IP Address

Displays the Local Area Network's (LAN) IP address.

LAN - Net Mask

Displays the Subnet Mask address configured for the LAN IP address.

LAN - DHCP Server

Displays the state of the DHCP Server (On or Off).

In the left hand column, there are other Status options available: **Routing Table**, **WAN Status**, **LAN Status**, and **Active User List**. Click to generate the option of choice.

Routing Table

Selecting **Routing Table** generates the “Routing Table” screen. This screen displays an overview of the Gateway’s routes.

Valid	Destination	Netmask	Gateway
✓	192.168.0.0	255.255.255.0	0.0.0.0

[Main](#)

WAN Status

Selecting **WAN Status** generates a “Current Status” screen. This screen displays an overview of the Gateway’s WAN (Wide Area Network) connection.

Current Status	
PPP Status	
Status:	Connecting...
User Name:	
Authentication Failure:	
Session Time:	0
Packets Sent:	
Packets Received:	
DSL Status	
VPI:	0
VCI:	32
DSL Mode:	MMODE
Connection Status:	Idle
Speed (down/up):	0 / 0 Kbps
ATM QoS class:	UBR
Near End CRC Errors (I/F):	0/0
Far End CRC Errors (I/F):	0/0
Near End RS FEC (I/F):	0/0
Far End RS FEC (I/F):	0/0

[Clear](#) [Main](#)

LAN Status

Selecting **LAN Status** generates the “Lan Port Status” screen. This screen displays an overview of the Gateway’s LAN (Local Area Network) port connections.

Lan Port Status

Ethernet

Link Speed: 100 Mbps

Packets Sent: 906

Packets Received: 695

USB

Link Speed: Disconnected

Packets Sent: 0

Packets Received: 0

Clear Main

Active User List

Selecting **Active User List** generates the “Active User List” screen. This screen displays a list of the users currently connected to the Gateway accessing the Internet with Network Address Translation (NAT) security activated.

Active User List

The Active User List below displays users on your local area network who are actively accessing the Internet.

The following information about the user's PC is displayed on the list: IP Address type (DHCP or Static), MAC address, IP address and Computer name (DHCP only).

Type	MAC	IP	PC Name
------	-----	----	---------

Main

Using Utilities

7

To access the Gateway’s Web-based Utilities, select **Utilities** from the “Main Menu” screen. The “Utilities” screen appears.

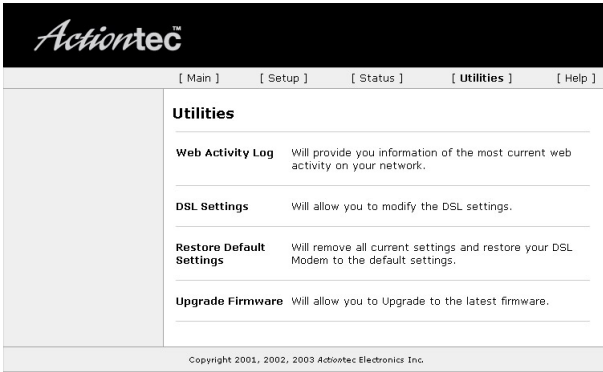

From this screen, the Web activity log can be viewed, the DSL settings changed, the Gateway’s factory default settings restored, and the Gateway’s firmware upgraded.

Web Activity Log

The Web Activity Log provides information about the Web sites each computer on the Gateway’s network has visited. To access the Web Activity Log, select **Web Activity Log** from the “Utilities” screen.



Auto Refresh

To set the Web Activity Log screen to automatically refresh at certain intervals, activate the circle next to “Auto Refresh Every” at the bottom of the Web Activity Log screen, then enter a time value (in seconds) in the text box, or click on the down arrow and select a time value from the menu that appears. The Web Activity Log will refresh at the chosen interval.

Manual Refresh

To set the Web Activity Log screen to manual refresh, activate the circle next to “Manual Refresh” at the bottom of the Web Activity Log screen. To refresh the Web Activity Log screen, click **Refresh**.

DSL Settings

To access DSL Settings, select **DSL Settings** from the “Utilities” screen. The Gateway’s VPI, VCI, Mode, and QoS (Quality of Service) settings can be changed from this screen. *Actiontec* recommends not changing these values without consulting the ISP.

DSL Settings

This screen is designed to allow modifying the default DSL settings for connection to your Broadband Service Provider. It is recommended to change these value only after consultation with your Broadband Service Provider.

VPI(0 - 255):

VCI(32 - 65535):

Mode: ▾

QoS: ▾

Restore Default Settings

To restore the Gateway to its factory default settings, select **Restore Default Settings** from the “Utilities” screen. When the “Restore Default Settings” screen appears, click **Restore Default Settings**. Any changes made to the Gateway’s settings in the Custom Setup screens will be lost and the factory default settings will be restored. During this process, the Gateway’s Power Light flashes and the Gateway is disabled.



Warning: Do not unplug the power cord from the Gateway during the Restore Default Settings process. Doing so may result in permanent damage to the Gateway.

When the Power Light stops flashing and glows steadily green, the Gateway is fully operational.



Upgrade Firmware

Selecting **Upgrade Firmware** in the “Utilities” screen generates the “Upgrade Firmware” screen. *Actiontec* periodically posts firmware upgrades to enhance the Gateway’s capabilities. Follow the instructions on-screen to upgrade the Gateway’s firmware.

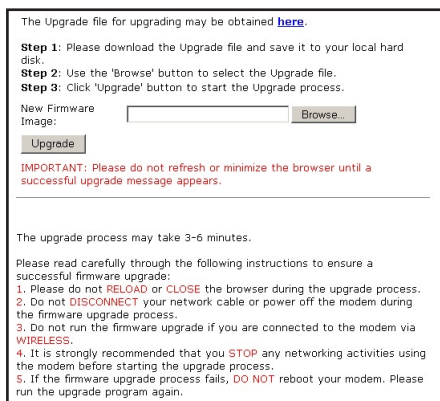

This page left intentionally blank.

Setting Up a Network

8

Other computers can be connected to the Gateway to form a network. The network computers can be connected to the Gateway in two ways: Ethernet or USB.

Ethernet

1. Insert the Installation CD in the CD-ROM drive of the computer. The Installation Buddy will start automatically. Wait until the following screen appears, read the on-screen instructions, then click **Next**.



2. Read the instructions, select **Adding Computers** by clicking on the appropriate check box, then click **Next**.



3. Select **Ethernet**, then click **Next**.



4. Read the on-screen instructions, choose the appropriate ISP option (indicated in the Welcome Letter), then click **Next**.
If **MSN** is selected, go to step 5.
If **Other IP** is selected, go to step 6.



5. Read the on-screen rental agreement, and if you accept it, click the circle next to “I accept the agreement.” Click **Next**.

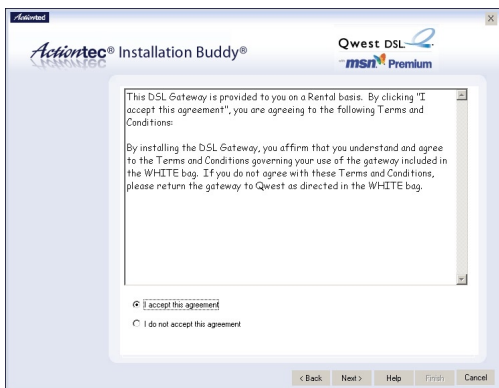

6. When the next window appears, get the **Yellow Ethernet Cable** from the Quick Start Kit, then click **Next**.



7. Plug one end of the **Yellow Ethernet Cable** into the **Yellow Port** on the back of the Gateway, then click **Next**.

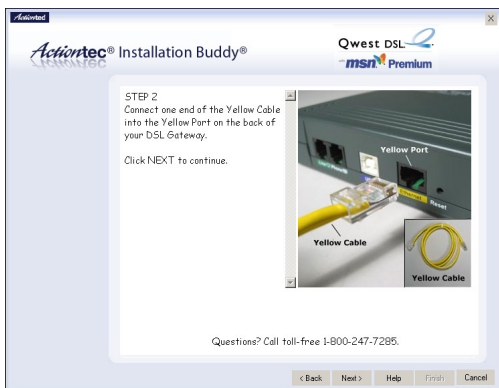

8. Plug the other end of the **Yellow Ethernet Cable** into an **Ethernet port** on the back of the computer, then click **Next**.



 **Note:** An Ethernet port looks similar to a phone port, but is slightly bigger.

9. Make sure one of the **Ethernet Network Lights** glow steadily green, then click **Next**.

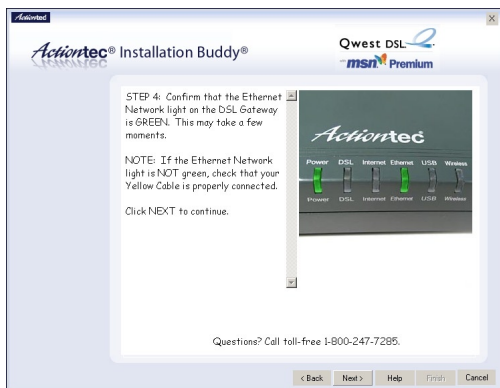

10. In the next window, the Installation Buddy checks the configuration of the Gateway.

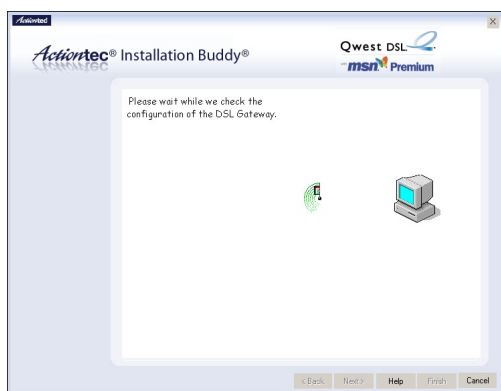

11. A congratulations window appears. The computer is connected to the network via Ethernet.

MSN:



Other ISPs:



USB

1. Insert the Installation CD in the CD-ROM drive of the computer. The Installation Buddy will start automatically. Wait until the following screen appears, read the on-screen instructions, then click **Next**.



2. Read the instructions, select **Adding Computers** by clicking on the appropriate check box, then click **Next**.



3. Select **USB**, then click **Next**.



4. Read the on-screen instructions, choose the appropriate ISP option (indicated in the Welcome Letter), then click **Next**.
If **MSN** is selected, go to step 5.
If **Other IP** is selected, go to step 6.



5. Read the on-screen rental agreement, and if you accept it, click the circle next to “I accept the agreement.” Click **Next**.

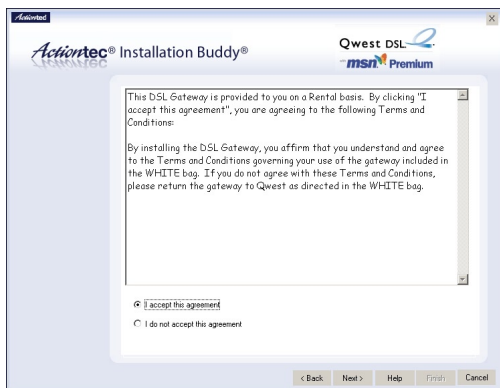

6. When the next window appears, get the **purple USB Cable** from the Quick Start Kit, then click **Next**.



7. Plug the square end of the **purple USB Cable** into the **Purple Port** on the back of the Gateway, then click **Next**.



8. Plug the other end of the **purple USB Cable** into an **USB port** on the front or back of the computer, then click **Next**.



9. Make sure the **Power**, **Internet**, and **USB Lights** glow steadily green, then click **Next**.

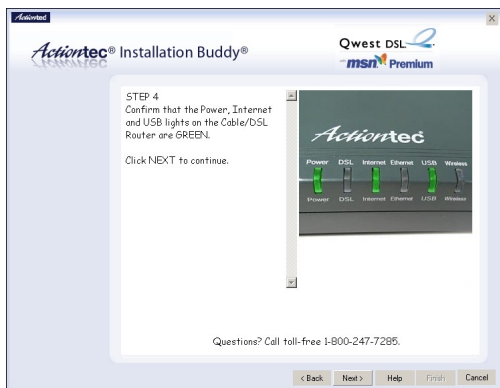

10. In the next window, the Installation Buddy checks the configuration of the Gateway.

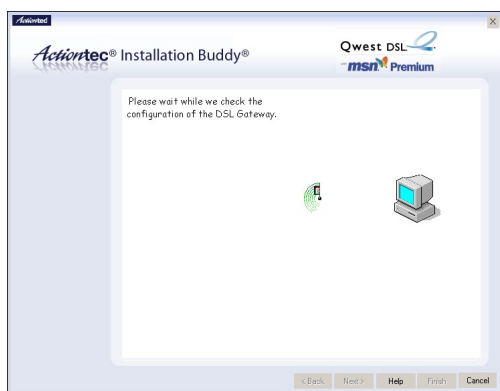

11. A congratulations window appears. The computer is connected to the network via USB.

MSN:



Other ISPs:



Troubleshooting

9

This chapter contains a list of problems that may be encountered while using the Gateway, and techniques to try and overcome the problem. Note that these techniques may not solve the problem.

LAN Connection Failure

- Ensure the Gateway is properly installed, the LAN connections are correct, and the power is on.
- Confirm the computer and Gateway are on the same network segment. If unsure, let the computer get the IP address automatically by initiating the DHCP function (see “DHCP Server”), then verify the computer is using an IP address within the default range (192.168.1.2 through 198.168.1.254). If the computer is not using an IP address within the range, it will not connect to the Gateway.
- Ensure the Subnet Mask address is set to 255.255.255.0 by clicking **Status** in the “Main Menu” screen.

Cannot Connect to the Internet

- Ensure both ends of the power cord and all network cables are properly connected.
- Ensure the Subnet Mask address is set to 255.255.255.0 by clicking **Status** in the “Main Menu” screen.
- Verify the Gateway’s settings are the same as the computer by clicking **Status** in the “Main Menu” screen.
- If running Windows 98 SE or Me, check the computer’s TCP/IP settings. Select **Start, Run**, enter

winipcfg

in the “Open” text box, then press **OK**. The “IP Configuration” window appears. Ensure the text box at the top of the window contains the name of the Ethernet adapter installed in the computer. If not, click on the down arrow next to the text box. When the list appears, click on the proper Ethernet adapter. In the fields below, the Ethernet adapter’s various addresses appear. There

should be an entry for IP address, Subnet Mask, and Default Gateway.

Additionally, the “IP Address” entry should be on the 192.168.0.X network (with “x” defining a range from 2 though 255).

If the Ethernet adapter is showing an incorrect IP address, click **Release**, which sets all values back to 0 (zero). Then, click **Renew** (this process may take a few seconds). The renewed IP address should be on the 192.168.0.X network.

If an error occurs, or the IP address renews with an address outside the 192.168.0.X network, contact the ISP immediately

- If running Windows 98 SE or Me, check the computer’s TCP/IP settings. Select **Start, Run**, enter

CMD

in the “Open” text box, then press **OK**. A “DOS” window appears, with a blinking cursor (prompt). Enter

ipconfig

at the prompt, then press **Enter** on the keyboard.

The IP address of the Ethernet adapter should appear in the DOS window. Ensure the IP address in the 192.168.0.X network (with “x” defining a range from 2 though 255).

If the Ethernet adapter is showing an incorrect IP address, enter

ipconfig/release

at the prompt, then press **Enter** on the keyboard, which sets all values back to 0 (zero). Next, enter

ipconfig/renew

at the prompt, then press **Enter** on the keyboard (this process may take a few seconds). The renewed IP address should be on the 192.168.0.X network.

If an error occurs, or the IP address renews with an address outside the 192.168.0.X network, contact the ISP immediately

- Ensure the browser is not set to “Never dial a connection” and there are no previous LAN settings.
To check this, go to **Start, Settings, Control Panel**. In the Control Panel, double-click **Internet Options**. When the “Internet Properties” window appears, ensure that the “Never dial a connection” option is not activated, then click **LAN Settings**. When the “Local Area Network (LAN) Settings” window appears, ensure that no settings are activated. If there are settings activated, deactivate them.
- Shutdown and restart the computer. After the computer restarts, unplug the power cord from the Gateway and plug it back in. When the lights glow solid green, try accessing the Internet.

Time out error occurs when entering a URL or IP Address

- Verify all the computers are working properly.
- Ensure the IP settings are correct.
- Ensure the Gateway is on and connected properly.
- Verify the Gateway's settings are the same as the computer by clicking **Status** in the "Main Menu" screen.
- Check the cable/DSL modem by attempting to connect to the Internet.

This page left intentionally blank.

Reference

A

This appendix contains information about various topics, including accessing information about your Windows computer.

Locating Computer Information

The following procedure is valid for Windows 98 SE, Me, NT 4.0, 2000 and XP.

1. From the desktop, right-click on **My Computer**.
2. Select **Properties** from the menu that appears.
3. When the “System Properties” window appears, select **General**.
The version of the operating system, processor type, and amount of RAM installed in the computer are listed here.
4. Close the System Properties window.
5. From the desktop, double-click on **My Computer**.
6. Right-click the icon representing your hard disk. For example: Local Disk (C:).
Some computers have multiple hard disks.
7. From the menu that appears, select **Properties**.
8. When the window appears, select **General**.
9. The Free space value is the available space on the hard disk.
10. Close all windows.

Locating Windows Operating System Files

If the operating system files reside on the hard drive of the computer, follow the instructions below to locate them. If the files are not on the hard drive, they must be loaded from the installation disks.

Windows 98 SE

1. From the desktop, click **Start**.
2. When the menu appears, select **Find**, then **Files or Folders**.
3. When the “Find: All Files” window appears, select **Name & Location**.
4. In the “Named” text box, enter:
***.cab**
5. Click the **down arrow** next to the “Look In” text box and select **My Computer** from the list that appears.
6. Click **Find Now**.
7. When the search is complete, note the directory path that appears most often in the “In Folder” column. For example: C:\WINDOWS\SYSTEM.
8. The Windows operating system files are located in this directory. Write down the directory path for future reference.
9. Close the Find: All Files window.

Windows Me, 2000

1. From the desktop, click **Start**.
2. Select **Search**, then **For Files and Folders**.
- 3a. **Windows Me:** The “Search Results” window appears. In the “Search for files or folders named” text box, enter:
***.cab**
- 3b. **Windows 2000:** The “Search Results” window appears. In the “Search for files or folders named” text box, enter:
i386

4. Click the **down arrow** next to the “Look in” text box and select **My Computer** from the list that appears.
5. Click **Search Now**.
- 6a. **Windows Me:** When the search is complete, note the directory path that appears most often in the “In Folder” column. For example:
C:\WINDOWS\OPTIONS\INSTALL.
- 6b. **Windows 2000:** When the search is complete, note the directory path that appears most often in the “In Folder” column. For example:
C:\WINNT\Driver Cache.
7. The Windows operating system files are located in this directory. Write down the directory path for future reference.
8. Close the Search Results window.

Windows NT 4.0

1. From the desktop, click **Start**.
2. When the menu appears, select **Find**, then **Files or Folders**.
3. When the “Find: All Files” window appears, select **Name & Location**.
4. In the “Named” text box, enter:
i386
5. Click the **down arrow** next to the “Look In” text box and select **My Computer** from the list that appears.
6. Click **Find Now**.
7. When the search is complete, note the directory path that appears most often in the “In Folder” column. For example: C:\.
8. The Windows operating system files are located in this directory. Write down the directory path (followed by “i386”) for future reference.
9. Close the Find: All Files window.

Windows Me, 2000

1. From the desktop, click **Start**.
2. Select **Search**, then **For Files and Folders**.
3. The “Search Results” window appears. In the panel at left titled “What do you want to search for?”, click **All files and folders**.
4. Another panel, titled “Search by any or all of the criteria below” appears. In the “Look in” text box, click the **down arrow** and select **My Computer** from the menu that appears.
5. In the “All or part of the file name” text box, enter:
i386
6. Click **Search**.
7. When the search is complete, note the directory path that appears most often in the “In Folder” column. For example: C:\WINDOWS \Driver Cache\.
8. The Windows operating system files are located in this directory. Write down the directory path (followed by “\i386”) for future reference.
9. Close the Search Results window.

Static IP Address on the Computer

B

To communicate with the Gateway from a computer on the network (to use the Web Configuration Utility, for example), the user may have to switch the IP address settings from DHCP-enabled to static IP, so that the computer and the Gateway are on the same subnet.

To set up static IP on a computer, select the operating system and follow the instructions.

 **Note:** The following procedures are based on the Gateway's factory default IP address. If the Gateway's IP address has been changed, enter the new IP address when instructed to enter an IP address.

Windows 98 SE

1. From the desktop, click on the **Start** button in the lower left corner.
2. From the menu that appears, select **Settings**.

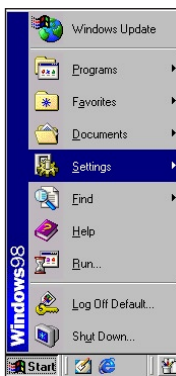

3. Another menu appears. Select **Control Panel**.

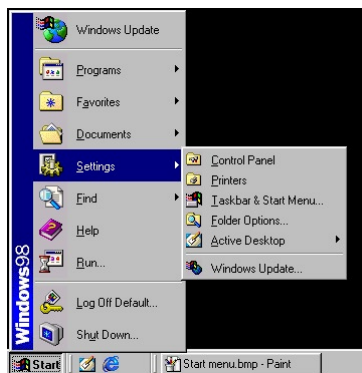

4. When the “Control Panel” window appears, double-click **Network**.

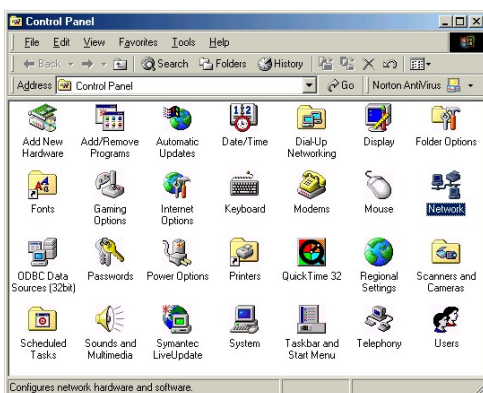

5. The “Network” window appears. In the “The following network components are installed” list box, locate and double-click TCP/IP.

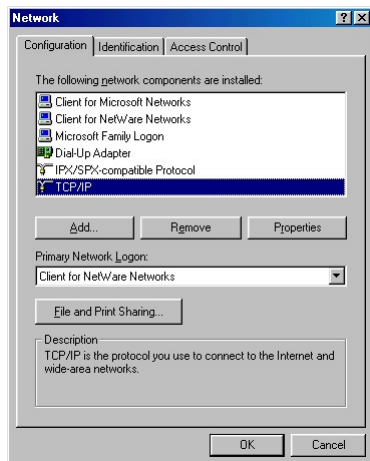

6. The “TCP/IP Properties” window appears. Select IP Address.

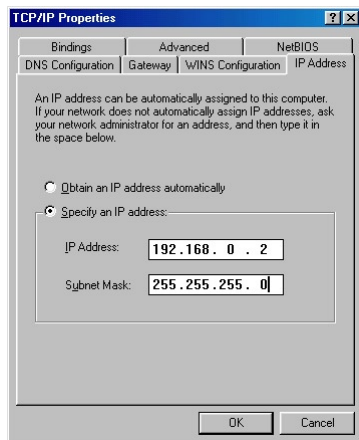

7. In the IP Address tab, make sure the circle next to “Specify an IP Address” is selected. When active, a black dot appears in the circle. If the circle already contains a black dot, leave it alone.
8. Enter the following numbers in the “IP Address” text box:
192.168.0.2
Press the space bar on the keyboard to add the periods between the numbers.

9. Enter the following numbers in the “Subnet mask” text box:

255 . 255 . 255 . 0

Press the space bar on the keyboard to add the periods between the numbers.

10. Click **OK**. The TCP/IP Properties window disappears.
11. In the Network window, click **OK**. The Network window disappears.
12. The “System Settings Change” window appears, asking whether the computer should be restarted. Click **Yes**.

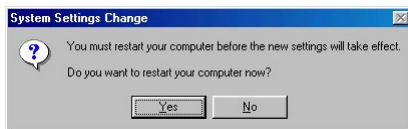

The computer restarts. It is now set up with a static IP address, allowing the user to access the Modem’s Advanced Setup utility.

Windows Me

1. From the desktop, click on the **Start** button in the lower left corner.
2. From the menu that appears, select **Settings**.

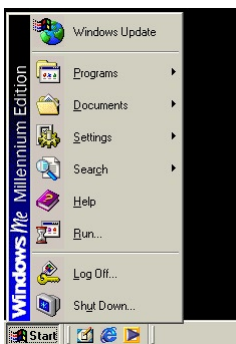

3. Another menu appears. Select **Control Panel**.

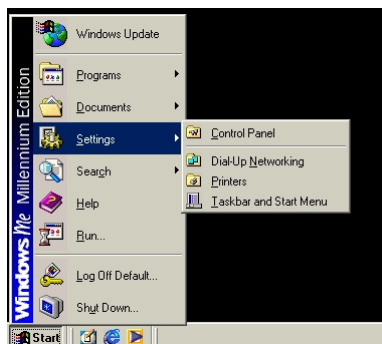

4. When the “Control Panel” window appears, double-click **Network**.

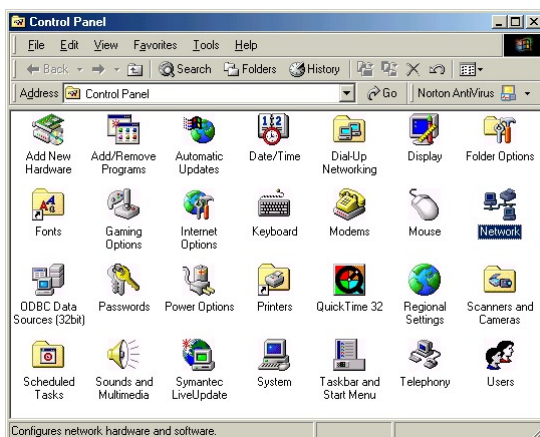

- The “Network” window appears. In the “The following network components are installed” list box, locate and double-click TCP/IP.

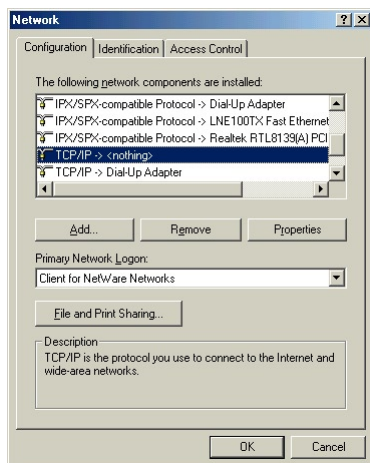

- The “TCP/IP Properties” window appears. Click **IP Address**.

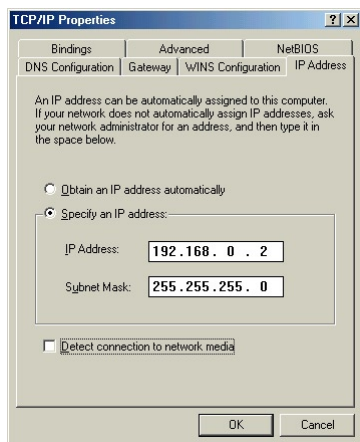

- In the IP Address tab, make sure the circle next to “Specify an IP Address” is selected. When active, a black dot appears in the circle. If the circle already contains a black dot, leave it alone.
- Enter the following numbers in the “IP Address” text box:
192.168.0.2
Do not include the periods; they are automatically entered.

9. Enter the following numbers in the “Subnet mask” text box:

255 . 255 . 255 . 0

Do not include the periods; they are automatically entered.

10. Click **OK**. The TCP/IP Properties window disappears.
11. If there is a check in the box next to “Detect connection to network media,” click on it to uncheck the box.
12. In the Network window, click **OK**. The Network window disappears.
13. The “System Settings Change” window appears, asking whether the computer should be restarted. Click **Yes**.

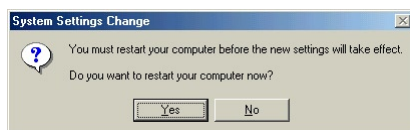

The computer restarts. It is now set up with a static IP address, allowing the user to access the Modem’s Advanced Setup utility.

Windows 2000

1. From the desktop, click on the **Start** button in the lower left corner.
2. From the menu that appears, select **Settings**.



3. Another menu appears. Select **Control Panel**.

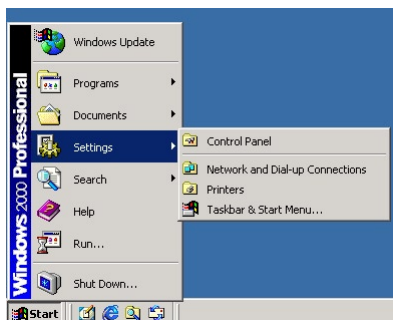

4. When the “Control Panel” window appears, double-click **Network and Dial-up Connections**.



- In the “Network and Dial-up Connections” window, double-click **Local Area Connection**. A number may be displayed after the Local Area Connection. If there is more than one Local Area Connection listed, locate the one that corresponds to the network card installed in the computer by finding the name of the network card in the **Device Name** column.

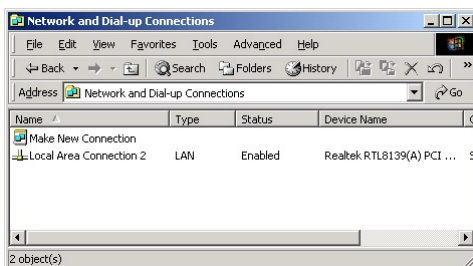

- The “Local Area Connection Status” window appears. Select **General**, then click **Properties**.

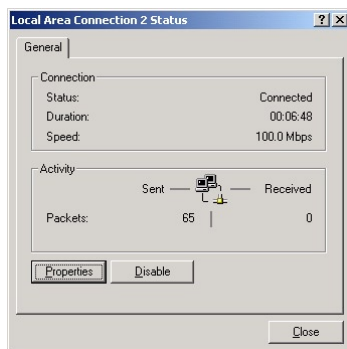

- The “Local Area Connection Properties” window appears. Click **General**.
- In the “Components checked are used by this connection” list box, double-click **Internet Protocol (TCP/IP)**.

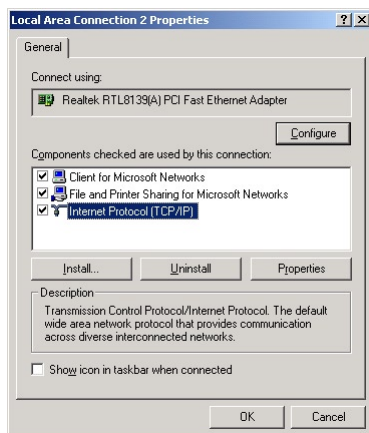

- The “Internet Protocol (TCP/IP) Properties” window appears.

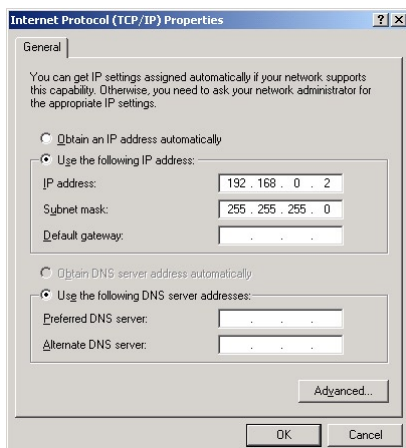

- In the **General** tab, make sure the circle next to “Obtain an IP Address automatically” is selected. When active, a black dot appears in the circle. If the circle already contains a black dot, leave it alone.
- Enter the following numbers in the “IP Address” text box:
192.168.0.2
Press the space bar on the keyboard to add the periods between the numbers.

12. Enter the following numbers in the “Subnet mask” text box:

255 . 255 . 255 . 0

Press the space bar on the keyboard to add the periods between the numbers.

13. Click **OK**. The “Internet Protocol (TCP/IP) Properties” window disappears.
14. In the “Local Area Connection Properties” window, click **OK**. The Local Area Connection Properties window disappears.
15. Click **Close** in the Local Area Connection Status window. The window disappears.
16. Close the Network and Dial-up Connections window by clicking on the “x” button at the upper right corner of the window.

The computer is now set up with a static IP address, allowing the user to access the Modem’s Advanced Setup utility.

Windows XP

1. From the desktop, click on the **Start** button in the lower left corner.
2. From the menu that appears, select **Settings**.



3. Another menu appears. Select **Control Panel**.

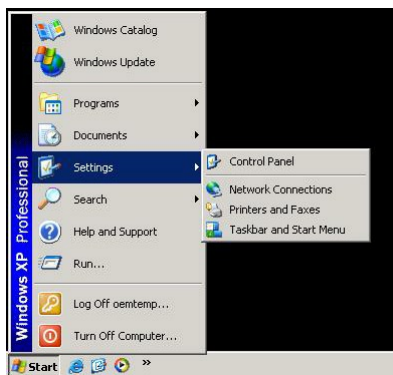

4. When the “Control Panel” window appears, double-click **Network Connections**.



5. In the “Network Connections” window, double-click **Local Area Connection**. A number may be displayed after the Local Area Connection. If there is more than one Local Area Connection listed, locate the one that corresponds to the network card installed in your computer by finding the name of the network card in the **Device Name** column.

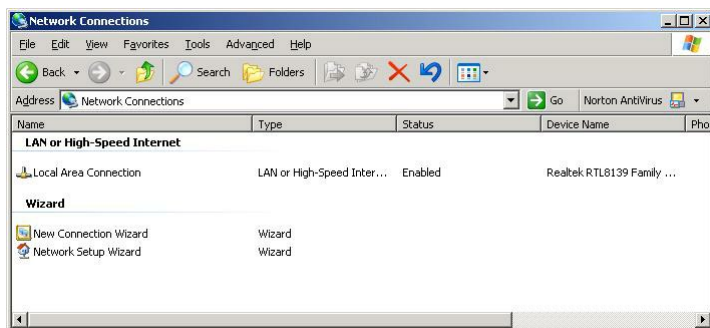

6. The “Local Area Connection Status” window appears. Select **General**, then click **Properties**.

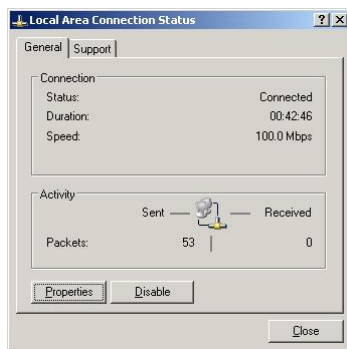

- The “Local Area Connection Properties” window appears. Select **General**.
- In the “Components checked are used by this connection” list box, double-click **Internet Protocol (TCP/IP)**.

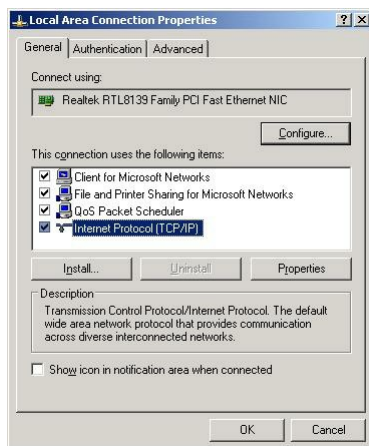

- The “Internet Protocol (TCP/IP) Properties” window appears.

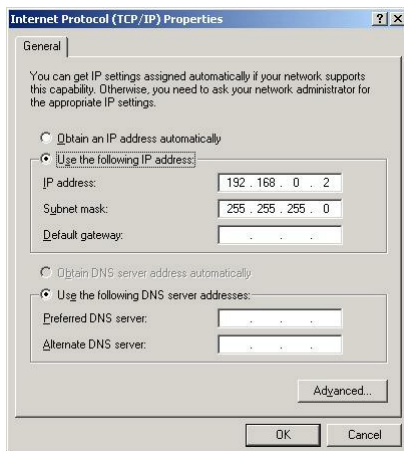

- In the **General** tab, make sure the circle next to “Obtain an IP Address automatically” is selected. When active, a black dot appears in the circle. If the circle already contains a black dot, leave it alone.

- 11.** Enter the following numbers in the “IP Address” text box:

192 . 168 . 0 . 2

Press the space bar on the keyboard to add the periods between the numbers.

- 12.** Enter the following numbers in the “Subnet mask” text box:

255 . 255 . 255 . 0

Press the space bar on the keyboard to add the periods between the numbers.

- 13.** Click **OK**. The Internet Protocol (TCP/IP) Properties window disappears.

- 14** In the Local Area Connection Properties window, click **OK**. The Local Area Connection Properties window disappears.

- 15.** Click **Close** in the Local Area Connection Status window. The window disappears.

- 16.** Close the Network and Dial-up Connections window by clicking on the “**x**” button at the upper right corner of the window.

The computer is now set up with a static IP address, allowing the user to access the Modem’s Advanced Setup utility.

This page left intentionally blank.

Computer Security



The Internet is a giant network of computers located all over the world. When a computer is connected to the Internet, it can exchange information with any other computer on the Internet. This allows a computer user to send E-mail, surf the World Wide Web, download files, and buy products and services online, but it also makes the computer vulnerable to attack from persons intent on doing malicious mischief, or worse. Unless access to the computer is controlled, someone on the Internet can access the information on the computer and damage or destroy that information.

Actiontec recommends securing your computer from unwanted intrusion. Security is ultimately the end user's responsibility. Please secure your computer, and don't be a victim.

Comparing DSL Service with a Dial-Up Modem

With a dial-up modem, a computer user makes an Internet connection by dialing a telephone number, surfs the Internet for a period of time, and then disconnects the dial-up modem. No one on the Internet can access a computer that is not connected to the Internet.

Unlike a dial-up modem, DSL service is "always connected." The connection is always available – there is no need to dial a phone number to access the Internet. The computer can be connected to the Internet all the time.

With both types of Internet connections, access to the computer must be controlled to make sure someone on the Internet doesn't access the information on the computer. The longer the computer is connected to the Internet, the easier it is for someone on the Internet to find the computer and attempt to access it without permission. DSL service also provides fast Internet connections. This not only improves Internet performance, it also improves Internet performance for anyone attempting to access the computer.

Gateway Security

If connecting to the ISP through Point-to-Point Protocol (PPP), be sure to provide the Gateway an administrative password. If a password is not set, someone on the Internet can access the Gateway and change its configuration or steal your PPP login name and password. For instructions on setting the password, see the “Advanced Setup chapter.

If connecting to the ISP through bridging mode, the Gateway should be safe from unwarranted and illegal intrusion.

Computer Security

To protect the valuable information on the computer, review the following topics. These topics cover software programs and operating system features affecting the security of the computer’s data.

Anti-Virus Programs

The computer should have an anti-virus program, and the virus definitions should be updated on a regular basis – at least once a month.

E-mail Attachments

Never run a program received as an attachment to an E-mail message unless the program is known to be safe. A program from an unknown source can delete all the files on the computer’s hard disk or install a “backdoor” software application that lets people on the Internet gain access to the computer without permission.

Internet Browsers

Always exit the Internet browser (Internet Explorer or Netscape Navigator, for example). Never “minimize” the browser or leave it open in the background. Breaking into a computer is easier when an Internet browser is running.

Network Applications

Network applications (such as software programs) that allow remote access to the computer also make the computer vulnerable to access from other people on the Internet. If using a network application that allows remote access, consider installing a firewall.

Electronic Security

Here are two methods to secure your computer electronically.

Network Address Translation

If a local area network and a PPP connection to the ISP using dynamic IP addresses through a DHCP server are being used, Network Address Translation (NAT) is being used. NAT provides a very basic level of security.

Firewalls

The safest way to prevent attacks on the computer is through a firewall – a hardware device or software program that protects the computer from unauthorized access by controlling who can access your computer and by monitoring the transmissions between the computer and the Internet

Windows XP has a built-in firewall. For more information, select **Help and Support Center** from the Help menu. Search for **Internet Connection Firewall**.

If Windows 98 SE, Me, NT 4.0, or 2000 is running on the computer, consider installing a firewall. Hardware and software firewall products are changing rapidly as more homes and businesses establish high-speed digital connections between their local area networks and the Internet.

This page left intentionally blank.

Specifications



General

Model Number

GT701-WG (54 Mbps Wireless Gateway)

Standards

IEEE 802.3 (10BaseT)
IEEE 802.3u (100BaseTX)
IEEE 802.11g (Wireless)
G.dmt
G.lite
t1.413
RFC 1483, 2364, 2516

Protocol

LAN - CSMA/CD
WAN - PPP, DHCP, Static IP

WAN

Full-rate ADSL Interface

LAN

10/100 RJ-45 switched port
USB port

Speed

LAN Ethernet: 10/100Mbps auto-sensing
Wireless: 802.11g 54 Mbps optimal (see “Wireless Operating Range” for details)

Cabling Type

Ethernet 10BaseT: UTP/STP Category 3 or 5
Ethernet 100BaseTX: UTP/STP Category 5
USB

Wireless Operating Range

Indoors

Up to 91 M (300 ft.)

Outdoors

Up to 533 M (1750 ft.)

Topology

Star (Ethernet)

LED Indicators

Power, DSL, Internet, Ethernet, USB, Wireless

Environmental

Power

External, 12V DC, 600mA

Certifications

FCC Class B, FCC Class C (part 15, 68), CE Mark Commercial, UL

Operating Temperature

0° C to 40° C (32°F to 104°F)

Storage Temperature

-20°C to 70°C (-4°F to 158°F)

Operating Humidity

10% to 85% non-condensing

Storage Humidity

5% to 90% non-condensing



Note: Specifications are subject to change without notice.

Glossary



Access Point

A device that allows wireless clients to connect to one another. An access point can also act as a bridge between wireless clients and a “wired” network, such as an Ethernet network. Wireless clients can be moved anywhere within the coverage area of the access point and remain connected to the network. If connected to an Ethernet network, the access point monitors Ethernet traffic and forwards appropriate Ethernet messages to the wireless network, while also monitoring wireless traffic and forwarding wireless client messages to the Ethernet network.

ATM (Asynchronous Transfer Mode)

A networking technology based on transferring data in fixed-size packets

Client

A desktop or mobile computer connected to a network.

DHCP (Dynamic Host Configuration Protocol)

A protocol designed to automatically assign an IP address to every computer on your network.

DNS (Domain Name System) Server Address

Allows Internet host computers to have a domain name and one or more IP addresses. A DNS server keeps a database of host computers and their respective domain names and IP addresses so that when a user enters a domain name into a Web browser, the user is sent to the proper IP address. The DNS server address used by computers on the home network corresponds to the location of the DNS server the ISP has assigned.

DSL (Digital Subscriber Line) Modem

A modem that uses existing phone lines to transmit data at high speeds.

Encryption

A method to allow wireless data transmissions a level of security.

ESSID (Extended Service Set Identifier)

A unique identifier for a wireless network. Also known as “SSID.”

Ethernet Network

A standard wired networking configuration using cables and hubs.

Firewall

A method preventing users outside the network from accessing and/or damaging files or computers on the network.

Gateway

A central device that manages the data traffic of your network, as well as data traffic to and from the Internet.

IP (Internet Protocol) Address

A series of four numbers separated by periods identifying a unique Internet computer host.

ISP Gateway Address

An IP address for the Internet router. This address is only required when using a cable or DSL modem.

ISP (Internet Service Provider)

A business that allows individuals or businesses to connect to the Internet.

LAN (Local Area Network)

A group of computers and devices connected together in a relatively small area (such as a house or an office). A home network is considered a LAN.

MAC (Media Access Control) Address

The hardware address of a device connected to a network.

NAT (Network Address Translation)

A method allowing all of the computers on a home network to use one IP address, enabling access to the Internet from any computer on the home network without having to purchase more IP addresses from the ISP.

PC Card

An adapter that inserts in the PCMCIA slot of a computer, enabling the communication with a device.

**PPPoE (Point-To-Point Protocol over Ethernet)/
PPPoA (Point-To-Point Protocol over ATM)**

Methods of secure data transmission.

Router

A central device that manages the data traffic of your network.

Subnet Mask

A set of four numbers configured like an IP address used to create IP address numbers used only within a particular network.

SSID

See “ESSID.”

TCP/IP (Transmission Control Protocol/Internet Protocol)

The standard protocol for data transmission over the Internet.

WAN (Wide Area Network)

A network that connects computers located in separate areas, (i.e., different buildings, cities, countries). The Internet is a WAN.

WECA (Wireless Ethernet Compatibility Alliance)

An industry group that certifies cross-vender interoperability and compatibility of IEEE 802.11b wireless networking products and promotes the standard for enterprise, small business, and home environments.

WLAN (Wireless Local Area Network)

A group of computers and other devices connected wirelessly in a small area.

Firewall Security

Level Services Table

F

The following information is related to the Firewall options (High, Medium, and Low) in the “Advanced Services” chapter of this manual (page 35). The types of services and their respective ports are listed in the two right-hand columns: the “In” column details whether a particular service can be accessed by a user outside of the network; and the “Out” column details whether a computer on the Gateway’s network can access a particular incoming service.

For example, in the “High Security Level” section below, the **http** service uses **port 80**. Since **no** is listed in the **In** column, a user outside the Gateway’s network cannot access a computer on the network via the http service; in this case, no computers on the network can be used as a Web server (i.e., to host a Web site accessible to outside users). However, since **yes** is listed in the **Out** column, all computers on the Gateway’s network can access the Internet via the http port.

If Basic Security is selected in the “Firewall” screen, firewall filtering is based on the basic NAT firewall.

 **Note:** This stateful packet inspection firewall is based on the Globespan-Virata implementation and specification for release 8.2.

High Security Level

Service	Port	In	Out
http	80	no	yes
dns	53	no	yes
ftp	21	no	no
telnet	23	no	yes
smtp	25	no	yes
pop3	110	no	yes
nntp	119	no	no
real audio/video	7070	no	yes
icmp	n/a	no	yes
H.323	1720	no	no
T.120	1503	no	no
SSH	22	no	no

Medium Security Level

Service	Port	In	Out
http	80	no	yes
dns	53	no	yes
ftp	21	no	yes
telnet	23	no	yes
smtp	25	no	yes
pop3	110	no	yes
nntp	119	no	yes
real audio/video	7070	yes	no
icmp	n/a	no	yes
H.323	1720	no	yes
T.120	1503	no	yes
SSH	22	no	yes

Low Security Level

Service	Port	In	Out
http	80	no	yes
dns	53	yes	yes
ftp	21	no	yes
telnet	23	no	yes
smtp	25	no	yes
pop3	110	no	yes
nntp	119	no	yes
real audio/video	7070	yes	no
icmp	n/a	yes	yes
H.323	1720	yes	yes
T.120	1503	yes	yes
SSH	22	yes	yes

Basic Security Level

NAT (Network Address Translation) only.

Service Acronym Definitions

http

HyperText Transfer Protocol This protocol delivers information over the Internet, and is used when a computer connects to a Web site via an Internet browser

dns

Domain Name System. A data query system used to translate host names into Internet addresses (i.e., www.somewebsite.com translates to 888.999.000.111)

ftp

File Transfer Protocol. A protocol used to transfer files over the Internet.

telnet

An Internet communications protocol enabling one computer to function as a terminal working from another (remote) computer.

smtp

Simple Mail Transfer Protocol. A protocol used to transfer E-mail between computers over the Internet. Can be used to send and receive mail.

pop3

Post Office Protocol 3. Another protocol used to transfer E-mail between computers. Usually employs a pop3 server, and is used to receive mail only.

nntp

Network News Transfer Protocol. A protocol used to distribute and retrieve news articles over the Internet.

real audio/video

A protocol used to transfer Real Audio or Real Video files.

icmp

Internet Control Message Protocol. Allows error messages, text packages, and informational messages to be transferred over the Internet.

H.323

A standard protocol for sending audio and video over the Internet.

T.120

A standard protocol for multimedia teleconferencing over the Internet.

SSH

Secure **Sh**ell. A method for the secure transfer of files from another computer. Also enables remote capabilities (terminal, log in).

Non-Windows System Setup



The Gateway supports both the Classic Macintosh operating systems (9.2.1 and below), as well as OS X.



Note: When installing any software, consult the user manual and help files supplied with the software for detailed information.

Actiontec provides the following information as a guideline only.

Classic

To configure the Gateway, Open Transport 2.5.2 or above must be loaded on the computer.

1. Click **Apple**, **Control Panels**, then **TCP/IP**.

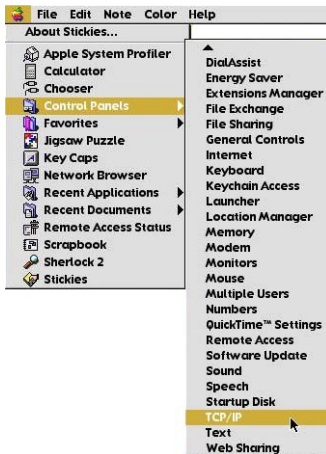

2. When the “TCP/IP” window appears, select **Edit** from menu bar, then select **User Mode**.
3. When the “User Mode” window appears, select **Advanced**, then click **OK**.
4. In the “TCP/IP” window, select **Ethernet** from the “Connect via” drop-down list.
5. Select **Using DHCP Server** from the “Configure” drop-down list.
6. Ensure the “Use 802.3” option is **not** checked.
7. Disregard any addresses in the IP Address text boxes. They will be reacquired when the first connection is made.
8. Click **Options** and when the “TCP/IP Options” window appears, select **Active**. Ensure the “Load only when needed” option is **not** checked, then click **OK**.
9. Close the “TCP/IP” window and when prompted to save changes, click **Save**.
10. Restart the computer. The TCP/IP settings are configured.

Next, go to “Connecting to the ISP” on page 136.

OS X

1. From the Apple Menu, select **System Preferences**.

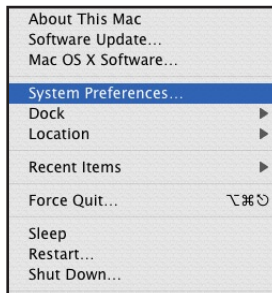

2. When the “System Preferences” window appears, click **Network**.



3. The Network window appears. Select **Built-In Ethernet** from the “Show” drop-down list.

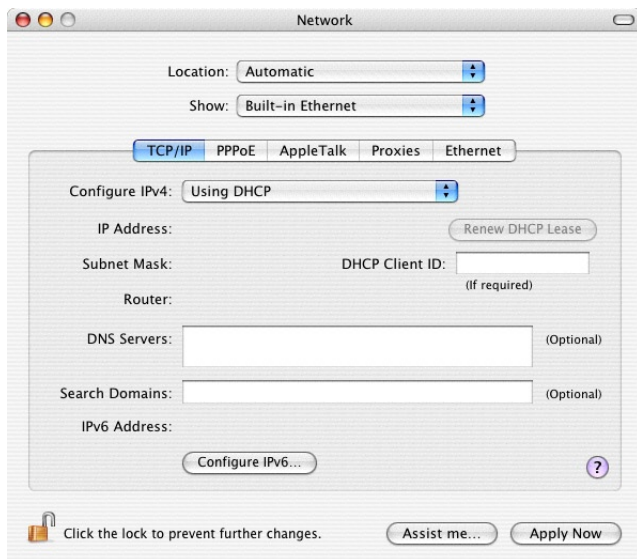

4. Select **TCP/IP** and, from the “Configure” drop-down list, select **Using DHCP**.
5. Click **Apply Now** and close the “System Preferences” application. The TCP/IP settings are configured.

Next, go to “Connecting to the ISP,” below.

Connecting to the ISP

1. Open the Web browser. In the address bar, enter
`http://192.168.0.1`
then press **Enter** on the keyboard.



- The “Main Menu” screen appears. Select **Setup/Configuration**.

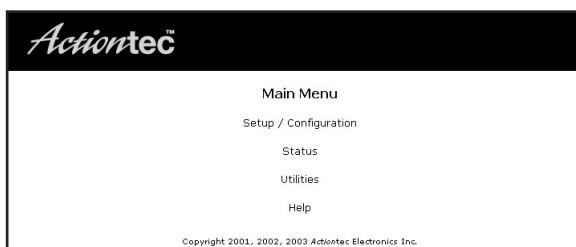

- In the “Set Up/Configuration” screen, select **Non-Windows Setup** from the menu on the left side.

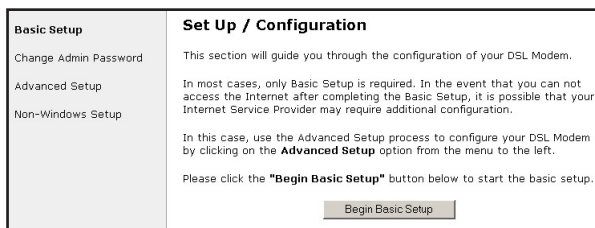

- The “Actiontec DSL Modem Setup Page” screen appears. In this screen, the user can configure the ISP Protocol (Bridged, PPPoA, or PPPoE) and the IP configuration (Dynamic or Static). Using the Internet Service Provider (ISP) Worksheet provided by the ISP, enter the information in the appropriate text boxes.
If no worksheet has been provided, contact the ISP.

Actiontec DSL Gateway Setup Page
The following will setup the router to work with your DSL provider.

The Actiontec DSL Gateway setup page can be used to setup your Gateway for the following configurations.

- 1) RFC1483 Bridged with DHCP. Bridging session terminated in the GT701-WG; via a DHCP address from the ISP. DHCP/NAT is used on the LAN side to run multiple LAN devices. (Same for RFC1483 Routed)
- 2) RFC1483 Bridged with Static IP. Bridging session terminated in the GT701-WG; via a single Static IP address from the ISP. DHCP/NAT is used on the LAN side to run multiple LAN devices. (Same for RFC1483 Routed)
- 3) PPPoA with dynamic IP Addressing. (Same for PPPoE)
- 4) PPPoA with a Single Static IP Address. (Same for PPPoE)

The advanced configuration session must be used to set the Gateway for transparent bridging and PPPoA with a block of static IP addresses.

Please locate your Internet Service Provider(ISP) worksheet. The ISP worksheet is required to complete the following. The ISP worksheet is sent separately from your DSL fulfillment package directly from your ISP of choice. If you do not have an ISP worksheet, please contact your ISP directly.

ISP Protocol

Please select the protocol below listed on your ISP worksheet.

RFC1483 Bridged

RFC1483 Routed

PPPoA

ISP Username

ISP Password

PPPoE

ISP Username

5. Click Save and Restart at the bottom of the Actiontec DSL Modem Setup Page screen.

The Gateway will be ready to use when the Power and Internet Lights stop blinking.

For other configuration options, see “Using Advanced Setup” on page 51.

Notices

Regulatory Compliance Notices

Class B Equipment

This equipment has been tested and found to comply with the limits for a Class B digital device, pursuant to Part 15 of the FCC Rules. These limits are designed to provide reasonable protection against harmful interference in a residential installation. This equipment generates, uses, and can radiate radio frequency energy and, if not installed and used in accordance with the instructions, may cause harmful interference to radio communications. However, there is no guarantee that interference will not occur in a particular installation. If this equipment does cause harmful interference to radio or television reception, which can be determined by turning the equipment off and on, the user is encouraged to try to correct the interference by implementing one or more of the following measures:

- Reorient or relocate the receiving antenna;
- Increase the separation between the equipment and receiver;
- Connect the equipment to an outlet on a circuit different from that to which the receiver is connected;
- Consult the dealer or an experienced radio or television technician for help.

Modifications

The FCC requires the user to be notified that any changes or modifications made to this device that are not expressly approved by *Actiontec Electronics, Inc.*, may void the user's authority to operate the equipment.

Declaration of conformity for products marked with the FCC logo – United States only.

This device complies with Part 15 of the FCC Rules. Operation is subject to the following two conditions:

1. This device may not cause harmful interference;

2. This device must accept any interference received, including interference that may cause unwanted operation.

 **Note:** To comply with FCC RF exposure compliance requirements, the antenna used for this transmitter must be installed to provide a separation distance of at least 20 cm from all persons and must not be co-located or operating in conjunction with any other antenna or transmitter.

For questions regarding your product or the FCC declaration, contact:

*Actiontec Electronics, Inc.
760 North Mary Ave.
Sunnyvale, CA 94086
United States
Tel: (408) 752-7700
Fax: (408) 541-9005*

Limited Warranty

Hardware: *Actiontec Electronics, Inc.*, warrants to the end user (“Customer”) that this hardware product will be free from defects in workmanship and materials, under normal use and service, for twelve (12) months from the date of purchase from *Actiontec Electronics* or its authorized reseller.

Actiontec Electronics’ sole obligation under this express warranty shall be, at *Actiontec*’s option and expense, to repair the defective product or part, deliver to Customer an equivalent product or part to replace the defective item, or if neither of the two foregoing options is reasonably available, *Actiontec Electronics* may, in its sole discretion, refund to Customer the purchase price paid for the defective product. All products that are replaced will become the property of *Actiontec Electronics, Inc.* Replacement products may be new or reconditioned. *Actiontec Electronics* warrants any replaced or repaired product or part for ninety (90) days from shipment, or the remainder of the initial warranty period, whichever is longer.

Software: *Actiontec Electronics* warrants to Customer that each software program licensed from it will perform in substantial conformance to its program specifications, for a period of ninety (90) days from the date of purchase from *Actiontec Electronics* or its authorized reseller. *Actiontec Electronics* warrants the media containing software against failure during the warranty period. The only updates that will be provided are at the sole discretion of *Actiontec Electronics* and will only be available for download at the *Actiontec* Web site, www.actiontec.com. *Actiontec Electronics*’ sole obligation under this express warranty shall be, at *Actiontec Electronics*’ option and expense, to refund the purchase price paid by Customer for any defective software product, or to replace any defective media with software which substantially conforms to applicable *Actiontec Electronics* published specifications. Customer assumes responsibility for the selection of the appropriate applications program and associated reference materials. *Actiontec Electronics* makes no warranty or representation that its software products will meet Customer’s requirements or work in combination with any hardware or applications software products provided by third parties, that the operation of the software products will be uninterrupted or error free, or that all defects in the software products will be corrected. For any third-party products listed in the *Actiontec Electronics* software product documentation or specifications as being compatible, *Actiontec Electronics* will make reasonable efforts to provide compatibility, except where the non-compatibility is caused by a “bug” or defect in the third party’s product or from use of the software product not in accordance with *Actiontec Electronics* published specifications or user guide.

THIS ACTIONTEC ELECTRONICS PRODUCT MAY INCLUDE OR BE BUNDLED WITH THIRD-PARTY SOFTWARE, THE USE OF WHICH IS GOVERNED BY A SEPARATE END-USER LICENSE AGREEMENT.

THIS ACTIONTEC ELECTRONICS WARRANTY DOES NOT APPLY TO SUCH THIRD-PARTY SOFTWARE. FOR THE APPLICABLE WARRANTY, PLEASE REFER TO THE END-USER LICENSE AGREEMENT GOVERNING THE USE OF SUCH SOFTWARE.

Obtaining Warranty Service: Customer may contact *Actiontec Electronics* Technical Support Center within the applicable warranty period to obtain warranty service authorization. Dated proof of purchase from *Actiontec Electronics* or its authorized reseller may be required. Products returned to *Actiontec Electronics* must be pre-authorized by *Actiontec Electronics* with a Return Merchandise Authorization (RMA) number marked on the outside of the package, and sent prepaid and packaged appropriately for safe shipment, and it is recommended that they be insured or sent by a method that provides for tracking of the package. The repaired or replaced item will be shipped to Customer, at *Actiontec Electronics*' expense, not later than thirty (30) days after *Actiontec Electronics* receives the defective product.

Return the product to:
(In the United States)
Actiontec Electronics, Inc.
760 North Mary Avenue
Sunnyvale, CA 94085

Actiontec Electronics shall not be responsible for any software, firmware, information, memory data, or Customer data contained in, stored on, or integrated with any products returned to *Actiontec Electronics* for repair, whether under warranty or not.

WARRANTIES EXCLUSIVE: IF AN ACTIONTEC ELECTRONICS' PRODUCT DOES NOT OPERATE AS WARRANTED ABOVE, CUSTOMER'S SOLE REMEDY FOR BREACH OF THAT WARRANTY SHALL BE REPAIR, REPLACEMENT, OR REFUND OF THE PURCHASE PRICE PAID, AT ACTIONTEC ELECTRONICS' OPTION. TO THE FULL EXTENT ALLOWED BY LAW, THE FOREGOING WARRANTIES AND REMEDIES ARE EXCLUSIVE AND IN LIEU OF ALL OTHER WARRANTIES, TERMS OR CONDITIONS, EXPRESS OR IMPLIED, EITHER IN FACT OR BY OPERATION OF LAW, STATUTORY OR OTHERWISE, INCLUDING WARRANTIES, TERMS OR CONDITIONS OF MERCHANTABILITY, FITNESS FOR A PARTICULAR PURPOSE, SATISFACTORY QUALITY, CORRESPONDENCE WITH DESCRIPTION, AND NON-INFRINGEMENT, ALL OF WHICH ARE EXPRESSLY DISCLAIMED. ACTIONTEC ELECTRONICS

Limited Warranty

NEITHER ASSUMES NOR AUTHORIZES ANY OTHER PERSON TO ASSUME FOR IT ANY OTHER LIABILITY IN CONNECTION WITH THE SALE, INSTALLATION, MAINTENANCE OR USE OF ITS PRODUCTS.

ACTIONTEC ELECTRONICS SHALL NOT BE LIABLE UNDER THIS WARRANTY IF ITS TESTING AND EXAMINATION DISCLOSE THAT THE ALLEGED DEFECT OR MALFUNCTION IN THE PRODUCT DOES NOT EXIST OR WAS CAUSED BY CUSTOMER'S OR ANY THIRD PERSON'S MISUSE, NEGLIGENCE, IMPROPER INSTALLATION OR TESTING, UNAUTHORIZED ATTEMPT TO OPEN, REPAIR OR MODIFY THE PRODUCT, OR ANY OTHER CAUSE BEYOND THE RANGE OF THE INTENDED USE, OR BY ACCIDENT, FIRE, LIGHTNING, OTHER HAZARDS, OR ACTS OF GOD.

LIMITATION OF LIABILITY: TO THE FULL EXTENT ALLOWED BY LAW, *ACTIONTEC ELECTRONICS* ALSO EXCLUDES FOR ITSELF AND ITS SUPPLIERS ANY LIABILITY, WHETHER BASED IN CONTRACT OR TORT (INCLUDING NEGLIGENCE), FOR INCIDENTAL, CONSEQUENTIAL, INDIRECT, SPECIAL, OR PUNITIVE DAMAGES OF ANY KIND, OR FOR LOSS OF REVENUE OR PROFITS, LOSS OF BUSINESS, LOSS OF INFORMATION OR DATA, OR OTHER FINANCIAL LOSS ARISING OUT OF OR IN CONNECTION WITH THE SALE, INSTALLATION, MAINTENANCE, USE, PERFORMANCE, FAILURE, OR INTERRUPTION OF ITS PRODUCT, EVEN IF *ACTIONTEC ELECTRONICS* OR ITS AUTHORIZED RESELLER HAS BEEN ADVISED OF THE POSSIBILITY OF SUCH DAMAGES, AND LIMITS ITS LIABILITY TO REPAIR, REPLACEMENT, OR REFUND OF THE PURCHASE PRICE PAID, AT *ACTIONTEC ELECTRONICS'* OPTION. THIS DISCLAIMER OF LIABILITY FOR DAMAGES WILL NOT BE AFFECTED IF ANY REMEDY PROVIDED HEREIN SHALL FAIL OF ITS ESSENTIAL PURPOSE.

Disclaimer: Some countries, states or provinces do not allow the exclusion or limitation of implied warranties or the limitation of incidental or consequential damages for certain products supplied to consumers, or the limitation of liability for personal injury, so the above limitations and exclusions may be limited in their application to you. When the implied warranties are not allowed to be excluded in their entirety, they will be limited to the duration of the applicable written warranty. This warranty gives you specific legal rights which may vary depending on local law.

Dispute Resolution: The customer may contact the Director of Technical Support in the event the Customer is not satisfied with *Actiontec Electronics'* response to the complaint. In the event that the Customer is still not satisfied with the response of the Director of Technical Support, the Customer is instructed to contact the Director of Marketing. In the event that the Customer is still not satisfied with the response of the Director of Marketing, the Customer is instructed to contact the Chief Financial Officer and/or President.

Governing Law: This Limited Warranty shall be governed by the laws of the State of California, U.S.A., excluding its conflicts of laws and principles, and excluding the United Nations Convention on Contracts for the International Sale of Goods.