

# The Mercedes 722.6; Not just another 5-speed



by Dennis Madden

Gear	B1	F1	K1	K2	F2	B3	K3	B2
1	X <sup>(1)</sup>	X			X		X <sup>(1)</sup>	X
2 <sup>(2)</sup> <small>Also default</small>			X		X		X <sup>(1)</sup>	X
3			X	X				X
4			X	X			X	
5	X	X <sup>(1)</sup>		X			X	
N	X						X	
N <small>Default</small>			X				X	
R	X <sup>(1)</sup>	X				X	X	
R <sup>(2)</sup>			X			X	X	

(1) For engine braking  
(2) When in 4X4 low (if equipped) or Winter mode (if equipped), and Reverse default mode

Figure 1 Chart at left

Mercedes introduced the 722.6 in 1996 – 10 years ago, and it seems we’re just now seeing these transmissions on a more regular basis. And why not? Chrysler is using this unit in many of its rear-wheel-drive applications, and in more to come. That being said, this transmission will wind up in shops all across the Country, not just in areas where there are high-end luxury cars sitting at every stop light.

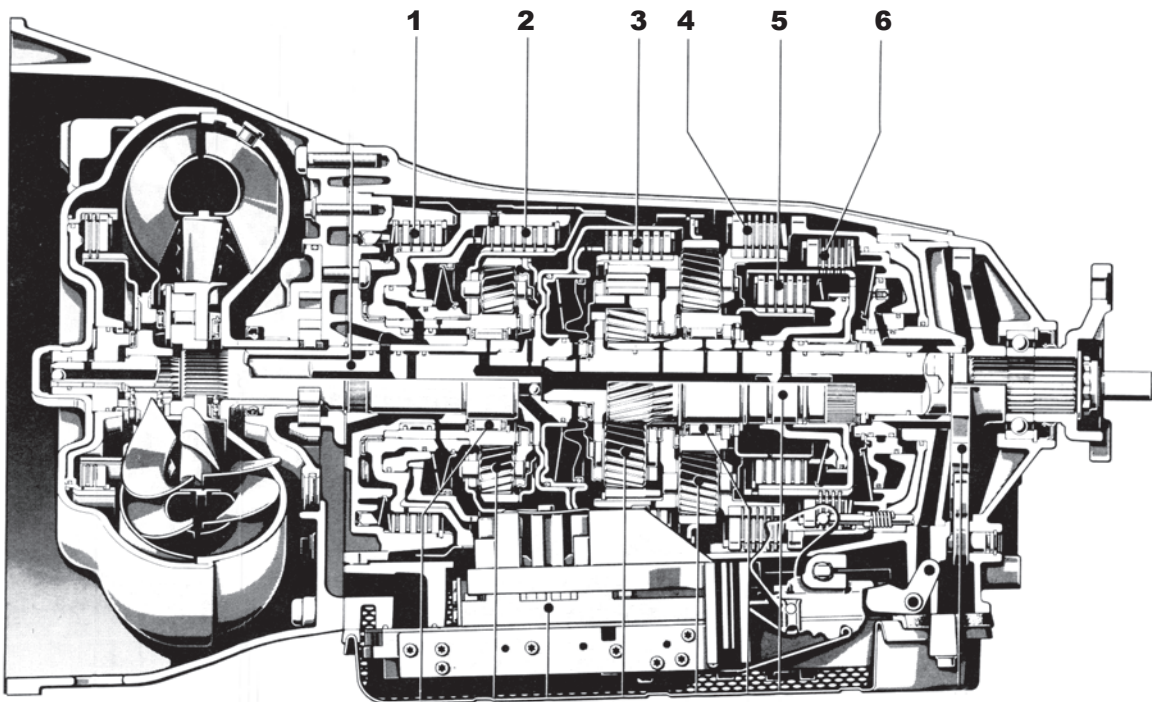

- 1 B1 Brake
- 2 K1 Clutch
- 3 K2 Clutch
- 4 B3 Brake
- 5 K3 Clutch
- 6 B2 Brake

Figure 1

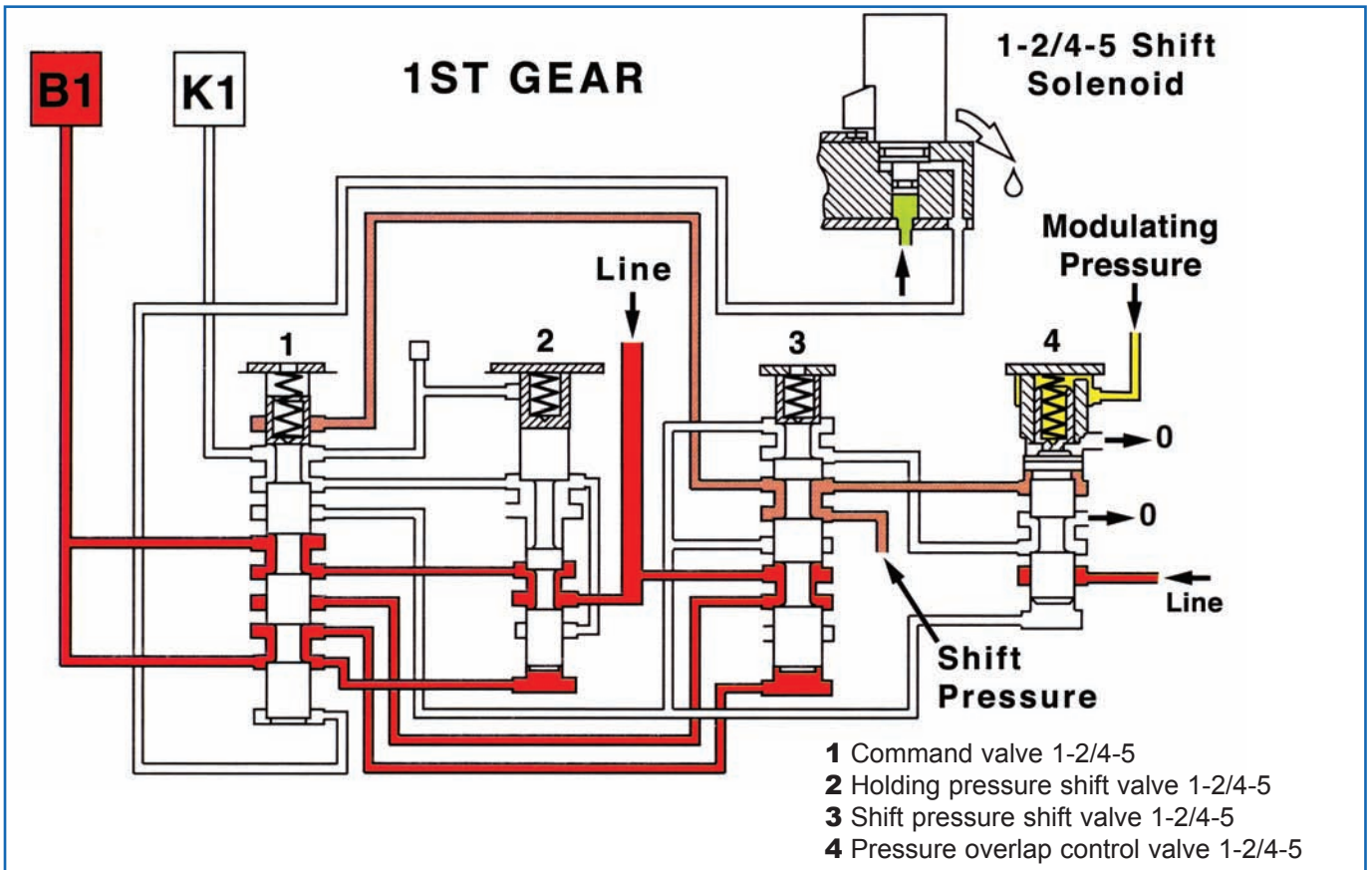

**FIGURE 2:** The B1 brake is applied (along with the B2 brake, K3 clutch, F1 and F2 sprags; not shown); the transmission is in 1<sup>st</sup> gear.

**This transmission uses six solenoids on the valve body to control transmission operation; three shift solenoids, a converter clutch solenoid, a pressure control solenoid, and a shift pressure control solenoid.**

Mercedes transmissions have always been a favorite for me. Not because I like their cars per-se, it's just that they always have some multi-step process for a simple clutch or band application, and it's like a puzzle to figure out. Almost like something Rube Goldberg would dream up. For those of you that don't remember, Rube

Goldberg was famous for designing complex machines for doing simple tasks. But this transmission is different, and for a change it's simple... relatively that is.

Let's get the easy stuff out of the way first. The Mercedes 722.6 uses six multi-plate clutches and two sprags (freewheels) to achieve its five forward and two reverse ranges. Yes, you read that right; two speeds for reverse. They use a standard mode and a winter mode. The winter mode uses a higher gear ratio which reduces the potential for wheel spin on snow or ice. Not all cars have this feature, but if they do there's an S/W switch located near the shifter to select the mode you want. This is a clutch-to-clutch unit, something we've all seen before. The chart in figure 1 shows what's applied in each gear.

Now for the fun part: You get one of these in and it's stuck in failsafe. You go through your normal routine; beginning with checking for codes and you decide you'll try energizing the solenoids to see if it'll shift through each gear. You dig up a connector view,

but when it comes to the solenoid firing order you discover, it's nowhere to be found; at least not one that makes any sense. The fact is, you won't find one. Solenoid operation for the 722.6 is unique, and different from every other transmission you've worked on.

So let's take a look at the solenoids on this unit and see if we can find any reminiscence of good ol' Rube. This transmission uses six solenoids on the valve body to control transmission operation; three shift solenoids, a converter clutch solenoid, a pressure control solenoid, and a shift pressure control solenoid. Mercedes uses terms for their solenoids that may not relate to an obvious function. The three shift solenoids: the 1-2/4-5 shift, 2-3 shift, and 3-4 shift solenoids are obvious. However, the lock up solenoid is referred to as a PWM solenoid, the pressure control solenoid is referred to as the modulating pressure regulator solenoid. The shift pressure control solenoid controls apply pressure to the clutch that's coming on during a shift transition. You'll see how that works

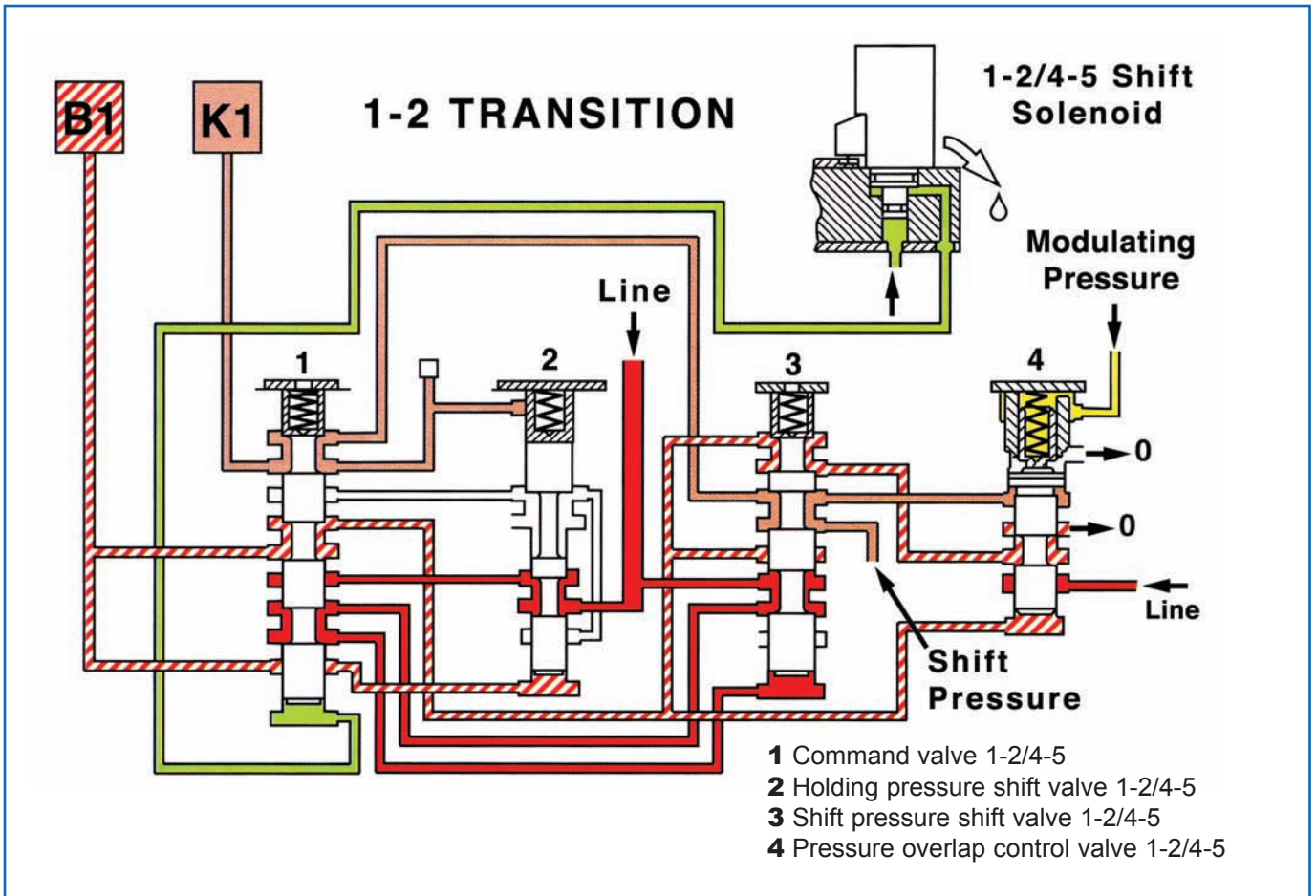

**FIGURE 3:** The Transmission Control Module energizes the 1-2/4-5 shift solenoid to initiate the shift to 2nd. The 1-2/4-5 shift solenoid strokes the 1-2/4-5 Command valve (1). Because the Holding Pressure shift valve (2) and the Shift Pressure shift valve (3) are also in the shifted (spring compressed) position, shift pressure is directed to the K1 clutch, and the B1 brake is directed to exhaust. The exhaust rate is controlled by the Pressure Overlap Control valve (4). There are three solenoids at play here: The 1-2/4-5 shift solenoid, the Shift Pressure control solenoid, which controls K1 pressure during the shift, and the Modulating Pressure control solenoid, which controls both line rise and the exhaust rate of B1 via the Pressure Overlap control valve (4). The shift to 2nd is in progress. Notice that B1 pressure is keeping the Holding Pressure shift valve (2) in the shifted position. During the shift, B1 pressure will drop to a point where it can no longer hold the Holding Pressure shift valve in the shifted position, causing it to stroke. This is the first stage of the "shift-completed" sequence. K1 is being held by Shift pressure, but that all ends once the TCM turns off the 1-2/4-5 shift solenoid.

**The basic operation of these four valves is the same for each shift. To initiate a shift transition the computer turns on one of the shift solenoids.**

when we go through a shift with oil schematics.

The modulating pressure regulating solenoid controls line rise by raising pressure to the spring side of the pressure regulator. This is a standard

function like most all computer-controlled transmissions. It also controls oil to the three overlap control valves. And again, you'll see how this works a bit later. The PWM solenoid is fairly standard in that it controls converter clutch operation.

Where the Mercedes transmission is radically different in solenoid operation is with the shift solenoids. Because each shift releases one clutch while applying another, timing is very important so you don't get a flare or bind-up during the shift "transition". Each shift solenoid uses a bank of four valves to control the shift transitions (figure 2). These valves are called:

1. Command Valve
2. Holding Pressure Shift Valve

3. Shift Pressure Shift Valve
4. Pressure Overlap Control Valve

Keep in mind that each shift solenoid uses four of these valves, so in total there are 12 valves that control all of the shift transitions.

The basic operation of these four valves is the same for each shift. To initiate a shift transition the computer turns on one of the shift solenoids. For example, for a 1-2 shift the computer turns on the 1-2/4-5 shift solenoid. This strokes the command valve and *initiates* a shift "transition" (figure 3). During each transition apply pressure is controlled by the shifting pressure control solenoid. The release rate is

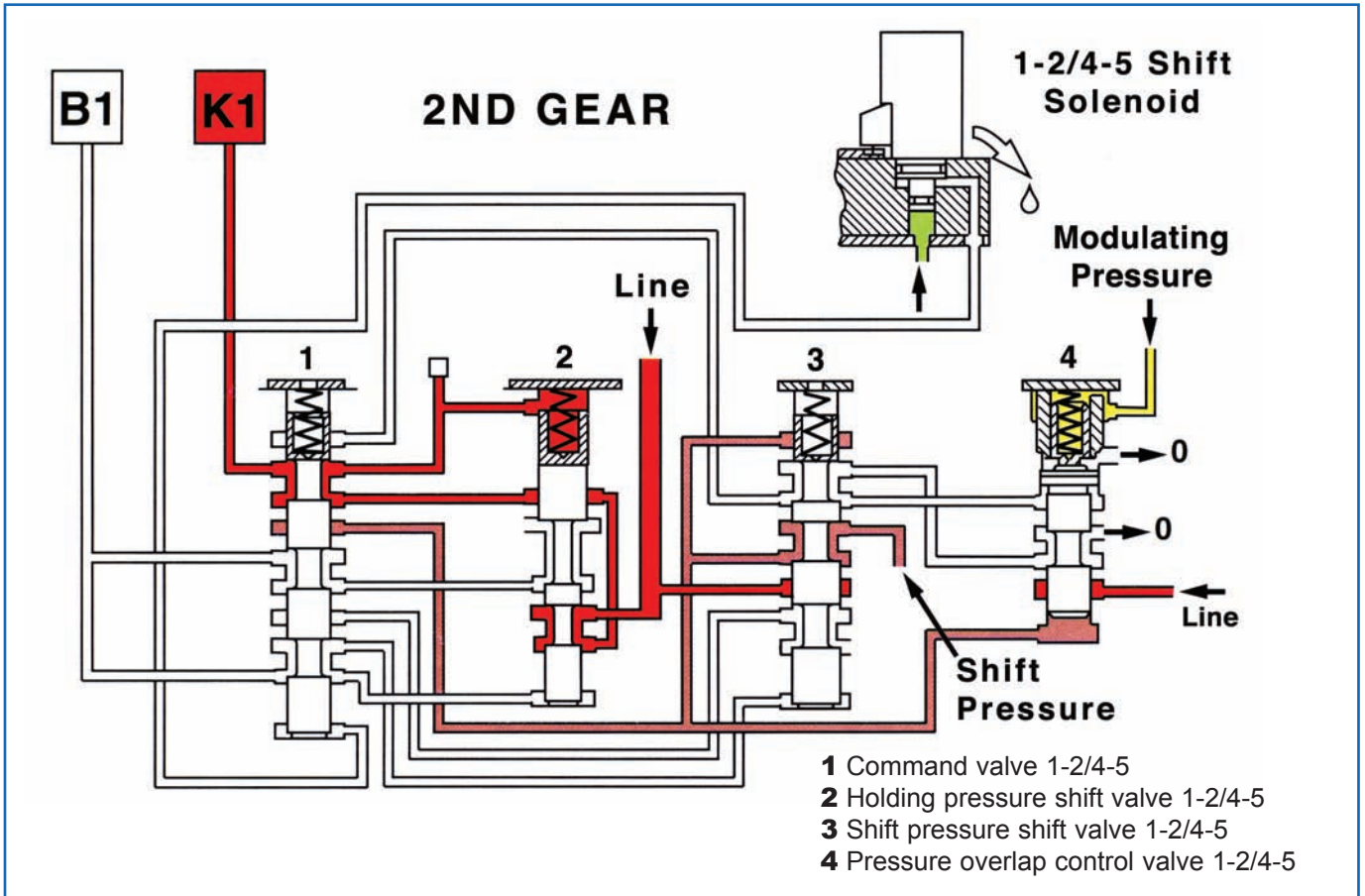

**FIGURE 4:** The TCM turns off the 1-2/4-5 shift solenoid, which releases the 1-2/4-5 Command valve (1). This delivers line oil to the K1 clutch. This movement of the 1-2/4-5 Command valve also releases the Shift Pressure shift valve (3). The transmission is fully engaged into 2<sup>nd</sup> gear and these four valves are in position to transition to either a 2-1 shift or a 4-5 shift.

**So now you're thinking... "Hey, if every gear has the solenoids off what's failsafe?"**

controlled, in part, by the modulating pressure regulator solenoid. These two solenoids work together with the other three valves (labeled 2, 3, and 4 above) to control the release rate of the B1 brake and the apply rate of the K1 clutch.

Once the transition is complete, the 1-2/4-5 shift solenoid is turned off (figure 4). To make a 2-1 down shift the computer again turns on the 1-2/4-5 shift solenoid to initiate a transition (figure 5). In this case, since the transmission is in second gear the transmission transitions back to first gear.

For a shift from second to third the 2-3 shift solenoid is energized to initiate the transition. And just like the 1-2 shift, once the transition is complete the solenoid is turned off. For a 3-2 downshift, the 2-3 shift solenoid goes through this cycle again. Each shift works in this fashion. So, the 1-2/4-5 shift solenoid transitions the B1 and K1 clutches. The 2-3 shift solenoid transitions the K2 and K3 clutches, and the 3-4 shift solenoid transitions the B2 and K3 clutches.

Now, here's something really interesting. Notice the name of the 1-2 shift solenoid: It's called the 1-2/4-5 shift

solenoid. Now look at the clutch application chart and notice what transition occurs during the 4-5 upshift. You got it. The clutch transition from 4<sup>th</sup> to 5<sup>th</sup> is *exactly the same as* the transition from 2<sup>nd</sup> to 1<sup>st</sup>! Remember I said that each time a shift solenoid is cycled the transmission transitions *that set of clutches*. So, for a 1-2 upshift the transmission releases the B1 brake and applies the K1 clutch. The shifts from 2<sup>nd</sup> to 3<sup>rd</sup> and 3<sup>rd</sup> to 4<sup>th</sup> occur and then the computer cycles the 1-2/4-5 solenoid again – just as though it were commanding a 2-1 downshift. The transmission releases the K1 clutch and applies the B1 brake. But now, because the K2 clutch is applied rather than the B2 brake, *this transition puts us in 5<sup>th</sup>, rather than 1<sup>st</sup>*. Once the shift is complete the shift solenoid for that transition turns off and stays off until another transition is commanded by the computer. So now you're thinking... "Hey, if every gear

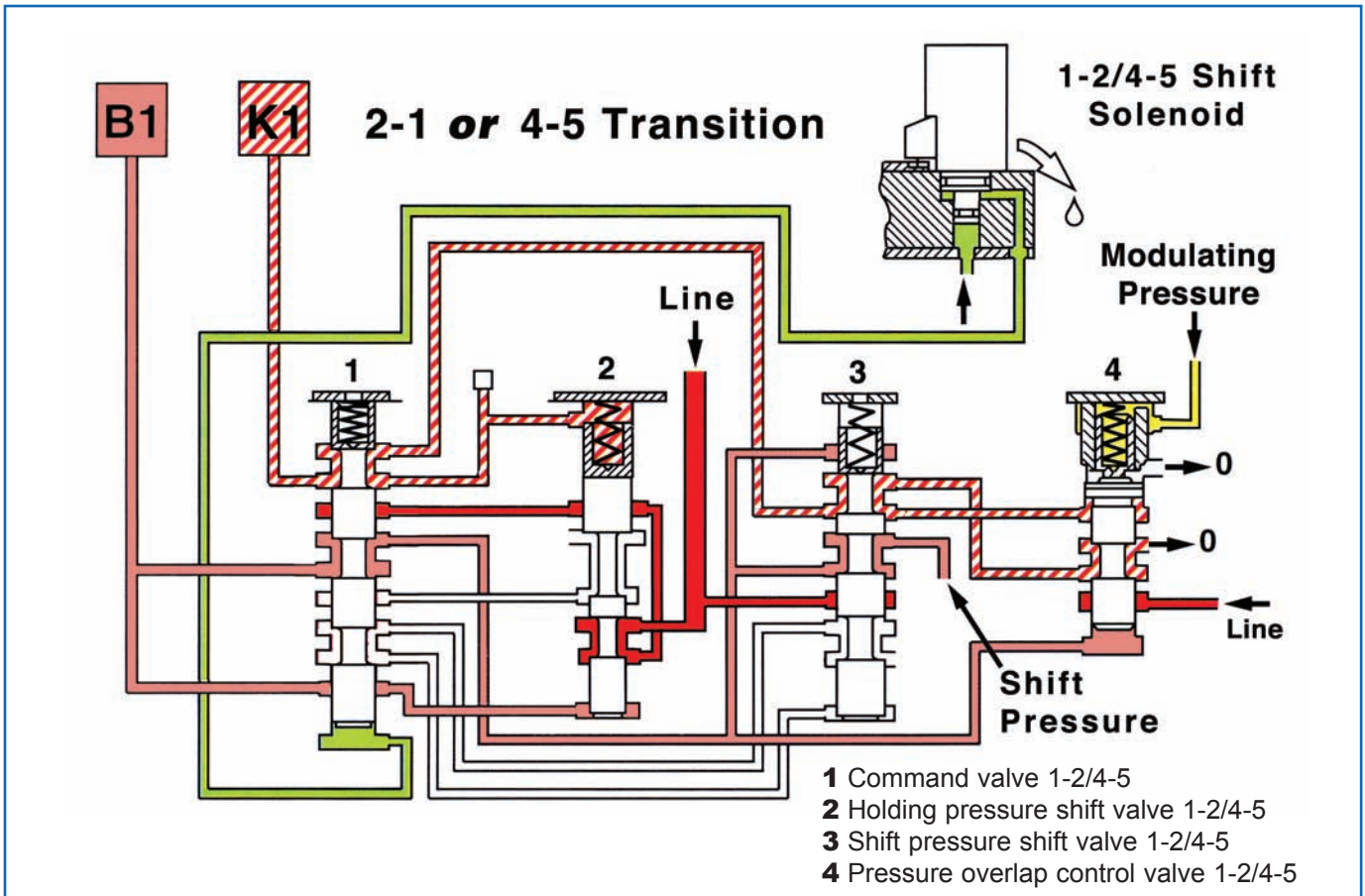

**FIGURE 5:** The TCM energizes the 1-2/4-5 shift solenoid to initiate the shift back to 1<sup>st</sup> gear. The 1-2/4-5 shift solenoid strokes the 1-2/4-5 Command valve (1). Because the Holding Pressure shift valve (2) and the Shift Pressure shift valve (3) are in the down shifted (spring relaxed) position, shift pressure is directed to the B1 brake, and the K1 clutch is directed to exhaust. The exhaust rate is controlled by the Pressure Overlap Control valve (4). B1 apply pressure is controlled by the Shift Pressure control solenoid, while K1 exhaust is controlled by the Modulating Pressure control solenoid via the Pressure Overlap control valve (4). The position of the Holding Pressure shift valve (2) is determined by B1 pressure (pressure rising) and K1 exhaust (pressure dropping). Once the conditions are met, the Holding Pressure control valve (2) strokes to the shifted position. The TCM turns off the 1-2/4-5 shift solenoid, releasing the 1-2/4-5 command valve (1), delivering line pressure to the B1 brake. The movement of the command valve also strokes the Shift Pressure shift valve (3). These four valves are now in the exact same position as in figure 2, 1<sup>st</sup> gear. **IMPORTANT:** Had the K2 clutch been applied during this transition rather than the B2 brake the transmission would have shifted from 4<sup>th</sup> to 5<sup>th</sup>, rather than 2<sup>nd</sup> to 1<sup>st</sup>.

**If the customer read their owner's manual they'd learn that in this situation they need to turn off the engine and restart it.**

has the solenoids off what's failsafe?" Now you're catchin' on. Since all three shift solenoids are off except during a shift the transmission stays in the last gear commanded prior to the failsafe occurrence. That is, if the transmission is in 1<sup>st</sup> gear and the computer goes to failsafe the transmission stays in 1<sup>st</sup>. If failsafe occurs on the freeway in 5<sup>th</sup> gear, the transmission stays in 5<sup>th</sup>. If the customer read their owner's manual they'd learn that in this situation they need to turn off the engine and restart it. Now when they move the shifter to Drive the transmission goes to 2<sup>nd</sup> gear

and stays there.

The 722.6 valve body has 19 valves (excluding the manual valve). When you consider there are three groups of shift transition valves that's 12 valves, leaving only 7 valves for all other transmission functions. When you get right down to it this transmission is pretty simple. One more thing; all six solenoids are pulse-width-modulated and have a low resistance so don't get cute and fire up the shift solenoids for any length of time with straight battery voltage. If you want to shift this transmission electrically use a 5-volt power supply.

That about does it for this issue of Shop Talk. As you can see where Mercedes is concerned simple doesn't quite mean simple, but it's closer than they've ever been in the past. I'm sure ol' Rube is lurking in the back room, waiting to get to work on one of there next transmissions. And when he does we'll be waiting.